



Guide for Certification of Floating Offshore Wind Turbine Installations

Effective from 1 August 2021

RINA
Via Corsica, 12 - 16128 Genova - Italy
Tel. +39 01053851 - Fax: +39 0105351000
E-MAIL info@rina.org - WEB www.rina.org

GENERAL CONDITIONS OF THE RULES *effective from 1/1/2021*

Definitions:

"Rules" in these General Conditions means the documents below issued by the Society:

- Rules for the Classification of Ships or other special units;
- Complementary Rules containing the requirements for certification of products, plants, systems and other or containing the requirements for the assignment of additional class notations;
- Rules for the application of statutory rules, containing the rules to perform the duties delegated by Administrations;
- Guides to carry out particular activities connected with Services;
- Any other technical document, as for example rule variations or interpretations.

"Services" means the activities described in Article 1 below, rendered by the Society upon request made by or on behalf of the Interested Party.

"Society" or "RINA" means RINA Services S.p.A. and/or all the companies in the RINA Group which provide the Services.

"Surveyor" means technical staff acting on behalf of the Society in performing the Services.

"Interested Party" means the party, other than the Society, having an interest in or responsibility for the Ship, product, plant or system subject to classification or certification (such as the owner of the Ship and his representatives, the ship builder, the engine builder or the supplier of parts to be tested) who requests the Services or on whose behalf the Services are requested.

"Owner" means the registered Owner, the ship Owner, the manager or any other party with the responsibility, legally or contractually, to keep the ship seaworthy or in service, having particular regard to the provisions relating to the maintenance of class laid down in Part A, Chapter 2 of the Rules for the Classification of Ships or in the corresponding rules indicated in the specific Rules.

"Administration" means the Government of the State whose flag the Ship is entitled to fly or under whose authority the Ship is authorised to operate in the specific case.

"Ship" means ships, boats, craft and other special units, as for example offshore structures, floating units and underwater craft.

"Client" means the Interested Party and any other party who requires the Services.

Article 1

1.1. - The purpose of the Society is, among others, the classification and certification of ships and the certification of their parts and components.

The Society:

- sets forth and develops Rules;
- publishes the Register of Ships;
- issues certificates, statements and reports based on its survey activities.

1.2. - The Society also takes part in the implementation of national and international rules and standards as delegated by various Governments.

1.3. - The Society carries out technical assistance activities on request and provides special services outside the scope of classification, which are regulated by these General Conditions, unless expressly excluded in the particular contract.

Article 2

2.1. - The Rules developed by the Society reflect the level of its technical knowledge at the time they are published. Therefore, the Society, though committed, also through its research and development services, to continuous updating, does not guarantee they meet state-of-the-art science and technology at the time of publication or that they meet the Society's or others' subsequent technical developments.

2.2. - The Interested Party is required to know the Rules on the basis of which the Services are provided. With particular reference to Classification Services, special attention is to be given to the Rules concerning class suspension, withdrawal and reinstatement. In case of doubt or inaccuracy, the Interested Party is to promptly contact the Society for clarification.

The Rules for Classification of Ships are published on the Society's website: www.rina.org.

2.3. - The Society exercises due care and skill:

- in the selection of its Surveyors
- in the performance of its Services, taking into account the level of its technical knowledge at the time the Services are performed.

2.4. - Surveys conducted by the Society include, but are not limited to, visual inspection and non-destructive testing. Unless otherwise required, surveys are conducted through sampling techniques and do not consist of comprehensive verification or monitoring of each component of the Ship or of the items subject to certification. The surveys and checks made by the Society, either on board ships or with remote techniques, do not necessarily

require the constant and continuous presence of the Surveyor. The Society may also commission laboratory testing, underwater inspection and other checks to qualified service suppliers, who will carry out these duties under their responsibility. Survey practices and procedures are selected by the Society based on its experience and knowledge and according to generally accepted technical standards in the sector.

Article 3

3.1. - The class assigned to a Ship, like the reports, statements, certificates or any other document or information issued by the Society, reflect the discretionary opinion of the Society concerning compliance, at the time the Service is provided, of the Ship or product subject to certification, with the applicable Rules (given the intended use and within the relevant time frame).

The Society is under no obligation to make statements or provide information about elements or facts which are not part of the specific scope of the Service requested by the Interested Party or on its behalf.

3.2. - No report, statement, notation on a plan, review, Certificate of Classification, document or information issued or given as part of the Services provided by the Society shall have any legal effect or implication other than a representation that, on the basis of the checks made by the Society, the Ship, structure, materials, equipment, machinery or any other item covered by such document or information meet the Rules. Any such document is issued solely for the use of the Society, its committees and clients or other duly authorised bodies and for no other purpose. Therefore, the Society cannot be held liable for any act made or document issued by other parties on the basis of the statements or information given by the Society. The validity, application, meaning and interpretation of a Certificate of Classification, or any other document or information issued by the Society in connection with its Services, are governed by the Rules of the Society, who is the sole subject entitled to make such authentic interpretation. Any disagreement on technical matters between the Interested Party and the Surveyor in the carrying out of his functions shall be raised in writing as soon as possible with the Society, which will settle any divergence of opinion or dispute.

3.3. - The classification of a Ship, or the issuance of a certificate or other document connected with classification or certification and in general with the performance of Services by the Society shall have the validity conferred upon it by the Rules of the Society at the time of the assignment of class or issuance of the certificate; in no case shall it amount to a statement or warranty of seaworthiness, structural integrity, quality or fitness for a particular purpose or service of any Ship, structure, material, equipment or machinery inspected or tested by the Society.

3.4. - Any document issued by the Society in relation to its activities reflects the condition of the Ship or the subject of certification or other activity at the time of the check.

3.5. - The Rules, surveys and activities performed by the Society, reports, certificates and other documents issued by the Society are in no way intended to replace the duties and responsibilities of other parties including, without limitation, Governments, designers, ship builders, manufacturers, repairers, suppliers, contractors or sub-contractors, Owners, operators, charterers, underwriters, sellers or intended buyers of a Ship or other product or system surveyed.

These documents and activities do not relieve such parties from any fulfilment, warranty, responsibility, duty or obligation (also of a contractual nature) expressed or implied or in any case incumbent on them, nor do they confer on such parties any right, claim or cause of action against the Society. With particular regard to the duties of the ship Owner, the Services undertaken by the Society do not relieve the Owner of his duty to ensure proper maintenance of the Ship and ensure seaworthiness at all times. Likewise, the Rules, surveys performed, reports, certificates and other documents issued by the Society are intended neither to guarantee the buyers of the Ship, its components or any other surveyed or certified item, nor to relieve the seller of the duties arising out of the law or the contract, regarding the quality, commercial value or characteristics of the item which is the subject of transaction.

In no case, therefore, shall the Society assume the obligations incumbent upon the above-mentioned parties, even when it is consulted in connection with matters not covered by its Rules or other documents.

In consideration of the above, and within the limits of liability under art. 5 below, the Interested Party undertakes to relieve and hold harmless the Society from any third party claim, as well as from any liability in relation to the latter concerning the Services rendered, where these are attributable to the Interested Party.

Insofar as they are not expressly provided for in these General Conditions, the duties and responsibilities of the Owner and Inter-

ested Parties with respect to the services rendered by the Society are described in the Rules applicable to the specific Service rendered.

Article 4

4.1. – Any request for the Society's Services shall be submitted in writing and signed by or on behalf of the Interested Party. Such a request will be considered irrevocable as soon as received by the Society and shall entail acceptance by the applicant of all relevant requirements of the Rules, including these General Conditions. Upon acceptance of the written request by the Society, a contract between the Society and the Interested Party is entered into, which is regulated by the present General Conditions.

4.2. – In consideration of the Services rendered by the Society, the Interested Party and the person requesting the service shall be jointly liable for the payment of the relevant fees and costs, even if the service is not concluded for any cause not pertaining to the Society. In the latter case, the Society shall not be held liable for non-fulfilment or partial fulfilment of the Services requested. In the event of late payment, interest at the legal current rate increased by 2% shall be paid.

4.3. - The contract for the classification of a Ship or for other Services may be terminated and any certificates revoked at the request of one of the parties, subject to at least 30 days' notice to be given in writing. Failure to pay, even in part, the fees due for Services carried out by the Society will entitle the Society to immediately terminate the contract and suspend the Services. The Society may withhold, suspend or withdraw any certificate, report or service in the event of non-payment of fees due to any member of the RINA Group by the Client in relation to the entire business relationship between any member of the RINA Group and the Client or by any other companies belonging to the same group as the Client. This also applies when the obligation to pay rests with a builder or with the Ship's previous Owner.

For every case of termination or suspension of the contract, the fees for the activities performed until the time of the termination or of the suspension shall be owed to the Society as well as the expenses incurred in view of activities already programmed; this is without prejudice to the right to compensation due to the Society as a consequence of the termination or of the suspension. With particular reference to Ship classification and certification, unless decided otherwise by the Society, termination of the contract implies that the assignment of class to a Ship is withheld or, if already assigned, that it is suspended or withdrawn; any statutory certificates issued by the Society will be withdrawn in those cases where provided for by agreements between the Society and the flag State.

Article 5

5.1. - In providing the Services, as well as other correlated information or advice, the Society, its Surveyors, servants or agents operate with due diligence for the proper execution of the activity. However, considering the nature of the activities performed (see art. 2.4), it is not possible to guarantee absolute accuracy, correctness and completeness of any information or advice supplied. Express and implied warranties are specifically disclaimed.

Therefore, subject to what provided for in paragraph 5.2 below, and also in the case of activities carried out by delegation of Governments, neither the Society nor any of its Surveyors will be liable for any loss, damage or expense of whatever nature sustained by any person, in tort or in contract, derived from carrying out the Services.

5.2. – Notwithstanding the provisions in paragraph 5.1 above, should any user of the Society's Services prove that he has suffered a loss or damage due to any negligent act or omission of the Society, its Surveyors, servants or agents, then the Society will pay compensation to such person for his proved loss, up to, but not exceeding, five times the amount of the fees charged for the specific services, information or opinions from which the loss or damage derives or, if no fee has been charged, a maximum of one hundred thousand Euro. Where the fees charged are related to a number of Services, the amount of the fees will be apportioned for the purpose of the calculation of the maximum compensation, by reference to the estimated time involved in the performance of the Service from which the damage or loss derives. Any liability for indirect or consequential loss, damage or expense is specifically excluded. In any case, irrespective of the amount of the fees charged, the maximum damages payable by the Society will not be more than 1 million Euro. Payment of compensation under this paragraph will not entail any admission of responsibility and/or liability by the Society and will be made without prejudice to the disclaimer clause contained in paragraph 5.1 above.

5.3. - Any claim for loss or damage of whatever nature by virtue of the provisions set forth herein shall be made to the Society in writing, within the shorter of the following periods: THREE MONTHS

from the date on which the Services were performed or THREE MONTHS from the date on which the damage was discovered. Failure to comply with the above deadline will constitute an absolute bar to the pursuit of such a claim against the Society. **Article 6**

6.1. - Any dispute arising from or in connection with the Rules or with the Services of the Society, including any issues concerning responsibility, liability or limitations of liability of the Society, will be determined in accordance with Italian Law and settled through arbitration assigned to a board of three arbitrators who will proceed in compliance with the Rules of the Chamber of National and International Arbitration of Milan. Arbitration will take place in Genoa, Italy.

6.2. - However, for disputes concerning non-payment of the fees and/or expenses due to the Society for Services, the Society shall have the right to submit any claim to the jurisdiction of the Courts of the place where the registered or operating office of the Interested Party or of the applicant who requested the Service is located.

In the case of actions taken against the Society by a third party before a judicial Court, the Society shall also have the right to summon the Interested Party or the subject who requested the Service before that Court, in order to be relieved and held harmless according to art. 3.5 above.

Article 7

7.1. - All plans, specifications, documents and information provided by, issued by, or made known to the Society, in connection with the performance of its Services, will be treated as confidential and will not be made available to any other party other than the Owner without authorisation of the Interested Party, except as provided for or required by any applicable international, European or domestic legislation, Charter or other IACS resolutions, or order from a competent authority. Information about the status and validity of class and statutory certificates, including transfers, changes, suspensions, withdrawals of class, conditions of class, operating conditions or restrictions issued against classed ships and other related information, as may be required, may be published on the website or released by other means, without the prior consent of the Interested Party.

Information about the status and validity of other certificates and statements may also be published on the website or released by other means, without the prior consent of the Interested Party.

7.2. - Notwithstanding the general duty of confidentiality owed by the Society to its clients in clause 7.1 above, the Society's clients accept that the Society will participate in the IACS Early Warning System which requires each Classification Society to provide other involved Classification Societies with relevant technical information on serious hull structural and engineering systems failures, as defined in the IACS Early Warning System (but not including any drawings relating to the ship which may be the specific property of another party), to enable such useful information to be shared and used to facilitate the proper working of the IACS Early Warning System. The Society will provide its clients with written details of such information sent to the involved Classification Societies.

7.3. - In the event of transfer of class, addition of a second class or withdrawal from a double/dual class, the Interested Party undertakes to provide or to permit the Society to provide the other Classification Society with all building plans and drawings, certificates, documents and information relevant to the classed unit, including its history file, as the other Classification Society may require for the purpose of classification in compliance with the applicable legislation and relative IACS Procedure. It is the Owner's duty to ensure that, whenever required, the consent of the builder is obtained with regard to the provision of plans and drawings to the new Society, either by way of appropriate stipulation in the building contract or by other agreement.

In the event that the ownership of the ship, product or system subject to certification is transferred to a new subject, the latter shall have the right to access all pertinent drawings, specifications, documents or information issued by the Society or which have come to the knowledge of the Society while carrying out its Services, even if related to a period prior to transfer of ownership.

Article 8

8.1. – RINA shall not be obliged to perform any obligation towards the Client (including, without limitation, obligation to (a) perform, deliver, accept, sell, purchase, pay or receive money to, from or through a person or entity, or (b) engage in any other act) if this would be in violation of, inconsistent with or expose RINA to punitive measures under any United Nations resolutions and/or under any laws, regulations, decrees, ordinances, orders, demands, requests, rules or requirements of EU, United Kingdom, and/or United States of America and which relate to foreign trade controls, export controls, embargoes or international boycotts

(applying, without limitation, to the financing, payment, insurance, transportation, delivery or storage of product and/or services) hereinafter referred to as "Trade Sanctions".

Recurring the above circumstances during the performance of the contract, RINA shall be entitled at its sole and absolute discretion: I) to immediately suspend payment or performance of the Services which are the object of the contract until such time as the Trading Sanctions are in force; and/or

II) to a full disengagement from the obligation affected by the Trading Sanctions, in the event that the inability to fulfill the said obligation persists until the term provided for the fulfilment hereunder, provided that where the relevant obligation relates to payments for activities and/or Services which have already been delivered, the affected payment obligation shall remain only suspended until such time as the Trading Sanctions no longer apply to the payment; and/or

III) to terminate the contract, without prejudice of the RINA's rights pursuant to article 4.3.

Article 9

9.1. – Should any part of these General Conditions be declared invalid, this will not affect the validity of the remaining provisions.

Article 10

10.1. – When the Society provides its Services to a consumer - i.e. a natural person who does not act within the scope of his business or professional activity - the following provisions do not apply: art. 3.2. (as far as the Society is solely entitled to the authentic inter-

pretation of the Rules); art. 4.2., (as far as the payment of the fees is also due for services not concluded due to causes not attributable to the Interested Party); art. 5.1. (as far as the exclusion of liability is concerned); art. 5.2.; art. 5.3.; and art. 6.1. (as far as the jurisdiction of a Board of Arbitrators based in Genoa is concerned).

Article 11

11.1. – RINA and the Interested Party shall promote safety, protect human health and environment and create safe working conditions for their personnel.

11.2. – The Interested Party shall guarantee that the working environment in which RINA's Surveyor will be required to work is adequate, safe and in all respect compliant with the applicable legislation and Rules and shall adopt all necessary measures to mitigate and/or control any relevant risk.

11.3. – Furthermore, in accordance with the applicable legislation and Rules, the Interested Party shall provide RINA with complete and detailed information relevant to any actual or potential specific risk existing in the work areas where the Surveyor will be required to operate and relevant to the performance of the Services as well as with any specific safety measure that RINA Surveyor is requested to comply with.

11.4. – RINA reserves not to commence and/or to suspend the Services and/or to terminate the contract, claiming compensation for any damage occurred, if it considers that the safety requirements listed in this article are not satisfactorily met.

INDEX

SECTION 1 – GENERAL PRINCIPLES

1 APPLICATION 1

2 CERTIFICATION 1

2.1 FOREWORD 1

2.2 CERTIFICATION TASKS FOR A FLOATING OFFSHORE WIND TURBINE INSTALLATION..... 2

2.3 DOCUMENTATION FOR CERTIFICATION 2

2.4 CONSTRUCTION DOSSIER 2

2.5 CERTIFICATION OF THE FABRICATION SURVEY 3

3 AMENDMENTS AND NOVEL TECHNOLOGIES 3

4 REFERENCE RULES FRAMEWORK 3

4.1 INTRODUCTION 3

4.2 GOVERNMENTAL RULES 3

4.3 OTHER RINA RULES AND INTERNATIONAL STANDARDS 3

4.4 BASIS OF DESIGN FOR CERTIFICATION 5

5 RECOGNIZED CERTIFICATION SCHEMES 5

SECTION 2 – TERMS AND DEFINITIONS

1 INTRODUCTION 6

2 DEFINITIONS 6

2.1 WIND TURBINE 6

2.2 ROTOR-NACELLE ASSEMBLY 6

 2.2.1 Rotor 6

 2.2.2 Nacelle-assembly 6

2.3 SUPPORT STRUCTURE 7

 2.3.1 Tower 7

 2.3.2 Floating Support Structure 7

 2.3.3 Stationkeeping system 7

2.4 DESIGN LIFE 7

2.5 LOCATION 7

2.6 WATER DEPTH 7

3 FLOATING SUPPORT STRUCTURES CHARACTERISTICS 7

3.1 COLUMN STABILIZED FLOATING SUPPORT STRUCTURE 8

3.2 SPAR TYPE FLOATING SUPPORT STRUCTURE 8

3.3 TLP TYPE FLOATING SUPPORT STRUCTURE 8

3.4 DEGREE OF FREEDOM 8

INDEX

SECTION 3 – SAFETY PHILOSOPHY AND DESIGN PRINCIPLES

1 SAFETY PHILOSOPHY 10

1.1 STRUCTURAL SAFETY REQUIREMENTS 10

1.2 RISK EXPOSURE LEVELS 10

 1.2.1 Determination of exposure level categories according to ISO Standard 10

 1.2.2 Determination of exposure level categories for Floating Offshore Wind Turbine Installations 10

 1.2.3 Notional safety targets..... 10

1.3 ROBUSTNESS REQUIREMENT 11

1.4 DESIGN ASSISTED BY MODEL TESTS..... 11

1.5 FUNCTIONAL REQUIREMENTS 11

2 DESIGN PRINCIPLES 11

2.1 METHODS OF ANALYSIS AND CALCULATION..... 11

 2.1.1 General..... 11

 2.1.2 Determination of loading effects..... 11

 2.1.3 Model tests 11

 2.1.4 Monitoring systems 12

2.2 DESIGN CRITERIA..... 12

 2.2.1 General..... 12

 2.2.2 Protection against accidental damage 12

 2.2.3 Accessibility for inspection 12

2.3 REASSESSMENT OF EXISTING STRUCTURES..... 13

2.4 STRUCTURE REUSE..... 13

3 APPENDIX A3 – LRFD FORMAT BASIC PRINCIPLES..... 13

3.1 WSD vs LRFD 13

3.2 OUTLINE PROCEDURE FOR DETERMINATION OF THE PARTIAL SAFETY FACTORS 14

SECTION 4 – ENVIRONMENTAL CONDITIONS

1 GENERAL 16

1.1 ENVIRONMENTAL PHENOMENA 16

1.2 ACCEPTABILITY OF THE PARAMETERS DEFINING THE DESIGN ENVIRONMENTAL CONDITIONS 16

1.3 DETERMINING PARAMETERS RELEVANT TO THE DESIGN ENVIRONMENTAL CONDITIONS 16

2 WIND CHARACTERIZATION 17

2.1 WIND CONDITIONS..... 17

2.2 WIND DATA..... 17

 2.2.1 Mean Wind Speed..... 17

 2.2.2 Wind Modeling..... 17

 2.2.3 Wind Speed Standard Deviation 18

 2.2.4 Turbulence Intensity 19

 2.2.5 Stochastic Turbulence Model 19

 2.2.6 Extreme Wind conditions 20

 2.2.7 Wind shear 21

 2.2.8 Wind direction..... 21

3 WAVES CHARACTERIZATION 21

INDEX

3.1	GENERAL	21
3.2	DETERMINISTIC DESCRIPTION OF WAVES	22
3.3	STOCHASTIC DESCRIPTION OF WAVES	23
3.3.1	Significant wave height	23
3.3.2	Peak period	23
3.3.3	Power spectral density	23
4	CURRENT CHARACTERIZATION	24
4.1	GENERAL	24
4.2	CURRENT DATA	24
4.3	CURRENT MODELLING	24
5	WATER DEPTH INCLUDING TIDAL VARIATIONS	24
6	TEMPERATURE	25
7	SEA ICE, ICE ACCRETION AND SNOW	25
8	MARINE FOULING	26
9	EARTHQUAKES	26
10	OTHER ENVIRONMENTAL CONDITIONS	26
11	SURROUNDING ENVIRONMENT CONDITIONS	27
 SECTION 5 – LOADS AND LOADING CONDITIONS		
1	INTRODUCTION	28
2	TYPES OF LOADS	28
2.1	GENERAL	28
2.2	PERMANENT LOADS	28
2.3	VARIABLE FUNCTIONAL LOADS	28
2.4	DEFORMATION LOADS	28
2.5	ENVIRONMENTAL LOADS	28
2.6	ACCIDENTAL LOADS	29
2.7	LOADS DUE TO CONSTRUCTION, TRANSPORTATION AND INSTALLATION	29
3	DETERMINATION OF ENVIRONMENTAL LOADS	30
3.1	GENERAL	30
3.2	WIND LOADS	30
3.2.1	General	30
3.2.2	Aerodynamic loads generated by the rotor	30
3.3	WAVE INDUCED LOADS	30
3.4	CURRENT INDUCED LOADS	32
3.5	ICE LOADS	32
3.6	SEISMIC LOADS	32
3.6.1	General	32

INDEX

3.6.2 Design requirements	32
4 DETERMINATION OF LOADING CONDITIONS	34
4.1 GENERAL	34
4.2 DESIGN LOAD CASES	34
4.2.1 Basic DLCs Requirements	34
4.2.2 Verification requirements for floating support structure and stationkeeping system	40
4.2.3 Partial Safety Factors applicable for DLCs	40
4.2.4 Additional DLCs for stationkeeping system	42
4.3 SURVIVAL LOAD CASES	42
5 APPENDIX A5 – AERODYNAMIC LOADS GENERATED BY ROTORS	43
5.1 GENERAL	43
5.2 AEROELASTIC LOADS CALCULATION	43
5.2.1 Wind field modelling	43
5.2.2 Aerodynamic model.....	44
5.2.3 Blade element momentum method	45
5.2.4 Beam theory	46
5.2.5 Control system	46
 SECTION 6 – SELECTION OF MATERIALS AND RELEVANT FABRICATION ISSUES	
1 INTRODUCTION	48
2 SELECTION OF STEEL MATERIAL	48
2.1 GENERAL	48
2.2 TYPE OF MATERIALS ACCORDING TO STRUCTURAL CATEGORY	48
2.3 STEEL PIPES	49
2.4 WELDABLE STRUCTURAL STEELS	49
2.4.1 General Requirements - Manufacturing procedure - Finishing grade and tolerance.....	49
2.4.2 Chemical Composition	49
2.4.3 Mechanical Properties.....	49
2.4.4 Additional Requirements	50
2.4.5 Tests.....	50
2.4.6 Material test certificates.....	51
2.4.7 Material of existing structures	51
2.5 FABRICATION AND WELDING	51
3 SELECTION OF CONCRETE MATERIAL	51
3.1 GENERAL	51
3.2 MATERIAL REQUIREMENTS	51
3.2.1 Cement.....	51
3.2.2 Aggregates	51
3.2.3 Water	52
3.2.4 Admixtures	52
3.2.5 Reinforcing steel.....	52
3.2.6 Prestressing tendons.....	52
3.3 DURABILITY ISSUES	52
3.3.1 Cement content	52
3.3.2 Water/cement ratio	52
3.3.3 Strength.....	52
3.3.4 Temperature.....	52

INDEX

3.3.5 Freezing and thawing53
 3.3.6 Abrasion53
 3.3.7 Concrete cover to reinforcement.....53
4 SELECTION OF MATERIALS FOR SOLID BALLAST53
 4.1 GENERAL53
5 SELECTION OF MATERIALS FOR THE MOORING SYSTEM53
 5.1 GENERAL53
 5.2 SELECTION OF MATERIAL FOR CHAINS53
 5.3 SELECTION OF MATERIAL FOR WIRE ROPES53
6 INSPECTION AND TESTING DURING FABRICATION AND CONSTRUCTION53
 6.1 GENERAL53

SECTION 7 – CONCEPT SELECTION

1 INTRODUCTION54
2 MAIN OFFSHORE WIND TURBINE PLATFORM CONCEPTS: FROM O&G TO WIND54
 2.1 INTRODUCTION54
 2.2 SEMISUBMERSIBLE OFFSHORE WIND TURBINE54
 2.3 TENSION LEG (TLP) OFFSHORE WIND TURBINE.....55
 2.4 SPAR OFFSHORE WIND TURBINE56
 2.5 MIXED CONFIGURATIONS56
 2.6 FLOATING SUPPORT STRUCTURES COMPARISON56

SECTION 8 – GLOBAL PERFORMANCE ANALYSIS

1 GENERAL58
2 GLOBAL RESPONSE ANALYSIS METHODOLOGIES59
 2.1 WAVE INDUCED MOTION RESPONSE59
 2.2 GLOBAL LOADS AND RESPONSE ANALYSIS59
 2.2.1 General.....59
 2.2.2 Frequency Domain Analysis59
 2.2.3 Time Domain Analysis.....59
 2.3 FLOATING OFFSHORE WIND TURBINE INSTALLATION MODEL.....60
 2.3.1 General.....60
 2.3.2 Coupled Analysis.....60
 2.3.3 Interface with the Wind Turbine60
 2.3.4 Undesirable effects.....60
 2.4 AIR GAP.....61
 2.5 MODEL TESTS61

INDEX

SECTION 9 – DESIGN OF FLOATING SUPPORT STRUCTURE

1 INTRODUCTION	62
2 PROVISIONS FOR STEEL STRUCTURES	62
2.1 GENERAL	62
2.1.1 Material properties and durability	62
2.1.2 Accessibility for inspection	62
2.2 STRENGTH DESIGN CRITERIA	62
2.2.1 Design Loading Conditions	62
2.2.2 Resistance Factors	62
2.2.3 Design Scantlings	62
2.3 STRUCTURAL ANALYSIS	63
2.3.1 Response evaluation	63
2.3.2 Methods of Analysis	63
2.4 STRENGTH ASSESSMENT	63
2.4.1 General	63
2.4.2 Structural components check	64
2.4.3 Tower/Hull interface	64
2.5 FATIGUE ASSESSMENT	64
2.5.1 General	64
2.5.2 Design fatigue life requirement	64
2.5.3 Fatigue sensitive components and connections	64
2.5.4 Loading conditions	65
2.5.5 Fatigue methodology	65
2.5.6 Fatigue analysis	65
2.5.7 Evaluation of cycling loads effects	65
2.5.8 Cumulative damage evaluation and fatigue safety check	66
2.5.9 Fatigue assessment for prior service	67
3 PROVISIONS FOR CONCRETE STRUCTURES	67
3.1 GENERAL	67
4 SPECIAL PROVISIONS FOR GIVEN TYPE OF FLOATERS	68
4.1 GENERAL	68

SECTION 10 – DESIGN OF STATIONKEEPING SYSTEM

1 STATIONKEEPING CONCEPT SELECTION	69
1.1 MOORING SYSTEM SELECTION	69
1.2 ANCHORING SYSTEM SELECTION	69
2 MOORING SYSTEM	70
2.1 DESIGN PRINCIPLES	70
2.2 ENVIRONMENTAL FORCES AND FLOATING STRUCTURE MOTIONS	70
2.3 GLOBAL DYNAMIC BEHAVIOUR	71
2.3.1 General	71
2.3.2 Uncoupled Analysis	71
2.3.3 Coupled Analysis	71
2.4 SIMULATION OF FLOATING STRUCTURES DYNAMICS	71

INDEX

2.4.1	General.....	71
2.4.2	Frequency domain analysis	71
2.4.3	Time domain approach.....	71
2.4.4	Combined time and frequency domain approach	71
2.5	SIMULATION OF MOORING LINE RESPONSE	72
2.6	STRENGTH ANALYSIS	72
2.6.1	General.....	72
2.6.2	Moorings strength analysis conditions	72
2.6.3	Strength analysis based on time domain simulations	72
2.6.4	Strength analysis based on combined time domain and frequency simulations	72
2.6.5	Strength design criteria for steel mooring lines and tendons	72
2.7	FATIGUE ANALYSIS.....	73
2.7.1	General.....	73
2.7.2	Fatigue analysis formulation	73
2.7.3	Fatigue analysis procedure	73
2.7.4	Fatigue design criteria for steel mooring lines and tendons.....	74
2.8	SYNTHETIC FIBER ROPE MOORING	74
3	ANCHORING SYSTEM.....	74
3.1	GENERAL	74
3.2	GEOTECHNICAL INVESTIGATION.....	74
3.3	DESIGN PRINCIPLES	75
3.3.1	General.....	75
3.3.2	Characteristic properties of soil	75
3.3.3	Effects of pulsating loads	75
3.3.4	Stability.....	75
3.3.5	Settlements and displacements	75
3.3.6	Slope stability	75
3.3.7	Hydraulic stability	75
3.3.8	Scour	76
3.4	DRAG ANCHORS.....	76
3.5	VERTICALLY LOADED DRAG ANCHORS.....	76
3.6	GRAVITY ANCHORS.....	77
3.7	CONVENTIONAL PILES	77
3.8	SUCTION PILES.....	77
4	APPENDIX A10 – OFFSHORE PILE FOUNDATION DESIGN	77
4.1	GENERAL REQUIREMENTS.....	77
4.2	ANALYSES TO BE PERFORMED.....	78
4.2.1	General.....	78
4.3	PILE DESIGN CRITERIA	78
4.4	PILE CAPACITY FOR AXIAL COMPRESSION	78
4.4.1	Ultimate bearing capacity	78
4.4.2	Skin friction and end bearing capacity of piles in clay soils (cohesive soil)	79
4.4.3	Skin friction and end bearing capacity of piles in sandy and silty soils (cohesionless soil)	79
4.4.4	Skin friction and end bearing capacity of piles grouted in rock.....	80
4.5	PILE CAPACITY FOR AXIAL PULLOUT LOADS	80
4.6	SOIL-PILE INTERACTION MODELLING	80
4.6.1	Axial performance	80
4.6.2	Lateral performance	81

INDEX

4.7 GROUP EFFECTS.....84
 4.8 PIPE WALL THICKNESS84

SECTION 11 – FLOATING STABILITY

1 GENERAL REQUIREMENTS85
 2 STABILITY IN SERVICE.....85
 3 INCLINING TEST/LIGHTWEIGHT CHECK.....85
 4 RIGHTING MOMENT AND HEELING MOMENT CURVES85
 5 INTACT STABILITY86
 5.1 SURFACE UNITS AND COLUMN STABILIZED UNITS86
 5.2 SPAR UNITS.....87
 5.3 TENSION LEG PLATFORMS87
 6 WATERTIGHT INTEGRITY87
 6.1 GENERAL87
 6.2 WATERTIGHT DOORS87
 7 CLOSING APPLIANCES87
 7.1 GENERAL REQUIREMENTS RELATED TO INTACT STABILITY FOR SURFACE UNITS87
 7.2 GENERAL REQUIREMENTS RELATED TO INTACT STABILITY FOR COLUMN STABILIZED UNITS.....87
 8 ICING88
 9 EFFECTS OF FREE SURFACES OF LIQUIDS IN TANKS88

SECTION 12 – MECHANICAL AND ELECTRICAL SYSTEMS

1 GENERAL REQUIREMENTS89
 2 MACHINERY SYSTEMS.....89
 2.1 BILGE SYSTEM.....89
 2.2 BALLAST WATER SYSTEM89
 2.3 VENTILATION ARRANGEMENT89
 2.4 AIR VENT & SOUNDING PIPE.....89
 2.5 MOORING EQUIPMENT89
 2.6 DYNAMIC CONTROL SYSTEMS89
 2.6.1 Vertical control system89
 2.6.2 Control and sensors89
 2.7 DYNAMIC BALLAST CONTROL SYSTEM.....89
 2.8 DYNAMIC MOORING SYSTEM90
 2.9 WIND-DIRECTION FOLLOW-UP.....90
 2.10 TRANSMISSION SYSTEM AND BRAKE90

INDEX

2.11	FIRE DETECTION & FIREFIGHTING SYSTEM	90
3	ELECTRICAL	90
3.1	GENERAL	90
3.2	EXPORT ELECTRICAL CABLE SYSTEM	90
3.3	LIGHTNING PROTECTION	90
 SECTION 13 – PROTECTION AGAINST CORROSION		
1	GENERAL	92
1.1	GENERAL REQUIREMENTS	92
1.2	SPLASH ZONE DEFINITION	92
2	CORROSION PROTECTION SYSTEMS	92
2.1	GENERAL	92
2.2	SELECTION CRITERIA	92
2.3	PROTECTION BY COATING SYSTEMS	93
2.3.1	Definitions.....	93
2.3.2	Protection by coating.....	93
2.3.3	Protection by cladding or lining.....	93
2.4	CATHODIC PROTECTION	93
2.4.1	General.....	93
2.4.2	Protection by sacrificial anodes.....	93
2.4.3	Protection by impressed current.....	94
2.5	CORROSION ALLOWANCE	94
2.5.1	General.....	94
2.5.2	Corrosion allowance for internal compartments.....	94
2.5.3	Corrosion allowance for chains.....	94
2.6	INSTALLATION AND TESTING OF EFFECTIVENESS OF THE SYSTEMS	95
2.6.1	General requirements.....	95
 SECTION 14 – MARINE OPERATIONS		
1	GENERAL REQUIREMENTS	96
1.1	APPLICATION	96
1.2	PLANNING AND EXECUTION	96
1.3	DOCUMENTATION AND SUPERVISION	96
1.4	ENVIRONMENTAL ACTIONS	96
1.5	STRUCTURAL ANALYSIS	96
1.6	WEIGHT CONTROL	96
1.7	FLOATING STABILITY	96
1.8	MOORING SYSTEMS	97
1.9	ELECTRICAL AND MECHANICAL SYSTEMS	97
1.10	INSTRUMENTATION	97
1.11	EQUIPMENT FOR SPECIAL OPERATIONS	97
2	LOAD TRANSFER OPERATIONS	97

INDEX

2.1	GENERAL REQUIREMENTS	97
3	TRANSPORTATION	97
3.1	GENERAL	97
3.2	TOWING OPERATIONS	98
4	OFFSHORE INSTALLATION	98
4.1	GENERAL	98
4.2	UNLOADING FROM TRANSPORT VESSEL	98
4.3	POSITIONING, BALLASTING AND ANCHORING	98
5	CONSTRUCTION OFFSHORE.....	99
5.1	GENERAL	99
5.2	MATING.....	99
5.3	LIFTING	99
6	POWER CABLE LAYING	99
6.1	GENERAL REQUIREMENTS.....	99
6.2	CABLE LAYING EQUIPMENT.....	99

SECTION 1 – GENERAL PRINCIPLES

1 Application

This document provides principles, technical requirements and guidance for the certification of floating offshore wind turbine installations.

The wording ‘Certification’ as used in this Guide, means that an item such as a system, equipment, structure etc. is designed, constructed and installed in compliance with this Guide or other specified regulations, as described in Clause 1.4.3.

This Guide is generally applicable to all types of support structures and stationkeeping systems used for design of support structures, foundations and mooring systems of offshore floating wind turbines.

Different floater types can be considered, also considering continuous technology development underway, depending on specific farm site conditions and economical boundaries for the choice of the wind turbine support structure. The optimal choice of the floater is subject of concept selection and feasibility studies phases, out of the scope of the present Guide: however, since it is typically based on floating offshore structures developed for the oil&gas industry, some guidance, with relevant features comparison, is reported in Section 7- Concept Selection.

Besides that, this Guide provides requirements for the following topics:

- Design principles;

- Selection of material and extent of relevant inspection for fabrication;
 - Characterization of design loads;
 - Structural design;
 - Mooring analysis and foundation design;
 - Durability;
 - Transport and installation;
 - In-service inspection,
- focused on the four common floater types that can be used for wind turbines:

- Spar;
 - Barge;
 - Tension Leg platform;
 - Semi-submersible,
- as sketched in the Figure 1.

This Guide is addressing site-specific design of the floating offshore support structures and relevant stationkeeping system for wind turbine installation, while it is not addressing the design of specific turbine components such as rotor, nacelle, generator and gear box.

This Guide do not apply to special components used for industrial operations and to those components which are not essential for the integrity of the floating unit, or the cables laid on the seabed, but considering these systems to the extent of both the floater motion analysis and the support structural design.

Figure 1: Floating Wind Turbine Concepts

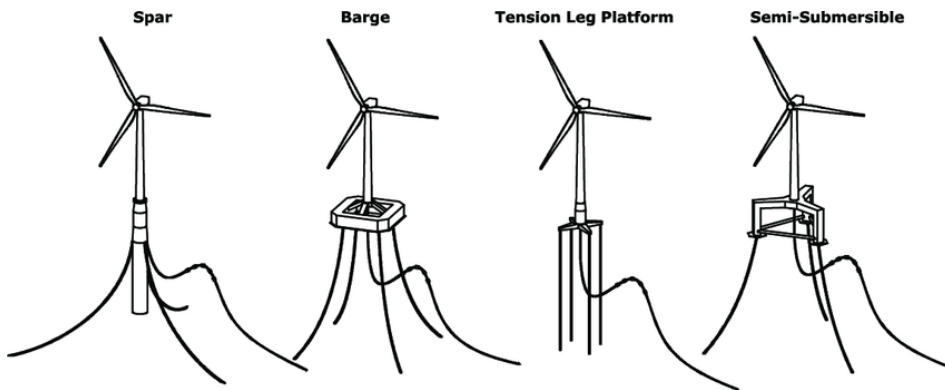

2 Certification

2.1 Foreword

RINA may act as a Third Party providing a Certification Service aimed to ensure the compliance of the design, manufacturing and construction of the whole floating offshore wind turbine installation, or material, components, piece of equipment thereof, with this Guide as well as with international standards, project specification or other documentation applicable for the purpose.

Through the execution of the certification services described in the following [3.2], the installations owner

may ask RINA to perform one or more tasks from the described ones, up to cover all the phases of a platform’s project, including:

- Basic design;
- Front end engineering design;
- Detailed design;
- Manufacturing of materials;
- Supply of equipment;
- Fabrication;
- Transportation;
- Installation;
- Life extension.

SECTION 1 – GENERAL PRINCIPLES

At the completion of the service, a final certification document is issued, which, according to the scope of work agreed upon the Parties (i.e. the installations Owner and RINA), may be referred as Certificate of Conformity, Test Certificate, Certificate of Compliance, etc.

The final Certificate is to address the following basic contents:

- Installations owner or contractor's name;
- Item(s) subject of certification;
- Applicable regulation, standards and specification;
- Certification tasks performed;
- List of examined project documents, tests performed, where applicable, traceability information, enclosures etc.,

in addition to other statements and information relevant to the outcomes of the certification activities deemed necessary by RINA or specifically required by the owner, and agreed by the interested Parties, on a case-by-case basis.

2.2 Certification tasks for a floating offshore wind turbine installation

The term "Certification" is used as covering one or more of the following tasks relevant to the realization of a new floating offshore wind turbine installation:

- Certification of the project, where a specific appraisal activity is performed by RINA on the design documentation relevant to the project of a floating offshore wind turbine installation, in order to verify and possibly certify the compliance of that design with this Guide and/or other design standards and project requirements, if applicable;
- Construction survey, where long term survey services, involving RINA personnel mobilized to construction sites, are carried out to verify and ensure that the fabrication of the offshore units, or components thereof, is compliant with the approved design documents and applicable specifications for construction; long term survey means that the required RINA supervision of the different items relevant to the units construction is to be performed by field surveyor(s) on the basis of a Quality Control Plan, see [1.2.5], agreed between the parties and covering the critical stages of the fabrication process.
- Vendor Inspection, expediting and auditing services, where short term activities, involving RINA personnel mobilized to supplier or vendor premises, are carried out to verify and ensure the compliance of materials, components and equipment with the technical requirements of the project.
- Certification of the marine operations and/or Marine Warranty Survey services,

where the purpose of RINA is to ensure that the operations relevant to mobilization of the construction yard, sea transportation and final offshore installation of the platform are carried out in compliance with applicable project documents and approved installation specifications and manual.

The marine operations that can be subject of certification are specifically addressed in Section 14 of this Guide.

The verification activities required for the certification are to be carried out through:

- Examination and approval of project documentation (drawings, specifications, manuals, etc.);
- Visits to be performed before the operation;
- Attendance during its development.

The certification is formalized through the release, in the different phases of development of the project operation, of documents' approval, inspection reports, statements of compliance and/or final certificates, as required for stating that the design, the planning and the execution of the complete offshore units installation or a single phase thereof, has been carried out in accordance with the applicable requirements and approved procedures. Typical examples of Certificates released during the different phases of the installation of an offshore wind farm are:

- Loadout Operation Approval Certificate,
- Seafastening Operation Approval Certificate;
- Transportation/ Towage Operation Approval Certificate
- Structure Installation Approval Certificate.

Specific certification activities may be also carried out for existing installations, as required by the owner for applicable tasks, as well as for renewal, removal, reuse or life extension of the floating support structures, when needed.

2.3 Documentation for Certification

Depending on the scope of work specifically required for the certification, the document subject to RINA appraisal are to be agreed with the wind farm's owner and clearly identified preliminary to the activities.

All the drawings or project documents describing the installation or equipment in its essential aspects, with respect to the certification scope of work, are to be provided and approved for those aspects of the drawings/documents concerning the final compliance with the applicable reference standards and safety targets.

2.4 Construction dossier

A construction dossier is to be made covering all the aspects of the installation construction in order to collect relevant information to be eventually the main reference for the certification of the fabrication.

SECTION 1 – GENERAL PRINCIPLES

The construction dossier is also recommended to be filed by the platform Owner, suitable for structural modifications/repair intervention possibly rising during the unit service life, as well as for extension life assessment.

- The construction dossier should include the following:
- a) Construction drawings as well as relevant material certificates;
 - b) Descriptions of welding procedures and deposited materials employed and to be employed;
 - c) Information relevant to performed tests and results;
 - d) Restrictions or prohibitions regarding repairs or modifications;
 - e) Relevant final installation records (such as final positioning, anchoring system installation records, etc.);
 - f) User’s manuals, if any;
 - g) Spare parts list.

2.5 Certification of the fabrication survey

In order to carry out the supervision aimed at providing the certification of the structures fabrication and/or installation in compliance with applicable drawings, specification and procedures, following to the approval of reference documents, the involvement of RINA Surveyor(s), mobilized to construction and/or installation sites, is required to verify and ensure the project compliance with the established safety and quality requirements.

Such requirements are to be included in a Quality Control Plan (QCP) describing all the fabrication/installation tasks in terms of activities to be carried out, items to be checked and tests to be performed along the construction sequences.

The QCP is to be prepared by the Owner, or its Contractors, and shared with RINA preliminary to any construction phase in order to identify the specific tasks that will be subjected to hold, witness or review activity by the RINA surveyor.

3 Amendments and Novel Technologies

The requirements specified in this Guide are aimed at ensuring a safety level that is deemed acceptable in the current practice established in the industry for design of floating structures.

Alternative designs and arrangements from those specifically addressed in these guidelines may be accepted, provided that it is documented that the level of safety is at least as high as the one implied by the requirements of this Guide.

Since design technology of offshore wind structures is not only a complex technology but is rapidly evolving, this Guide will be subject to review and updating as deemed necessary based both on experience and on future development.

Also, technology qualification procedures will be helpful for the purpose of new concept acceptability and eventual certification.

To this aim, reference can be made to the following RINA documents:

RINA GUI.16	Guide for Technology Qualification Processes
RINA GUI.19	Guide for Approval In Principle of Novel Technologies

4 Reference Rules Framework

4.1 Introduction

The application of the principles and technical requirements contained in this document is considered as part of the basis for obtaining RINA certification of the structure.

The certification of an offshore wind turbine with RINA or, more generally, any RINA act and decision does not relieve the interested parties from their duty of complying with any additional and/or more stringent requirements issued by the competent Administration and the relevant provisions for this application.

4.2 Governmental rules

These guidelines are written for worldwide application. National and governmental regulations may supplement or overrule the requirements of this standard as applicable.

4.3 Other RINA rules and International Standards

For matters not expressly specified or modified by these guide, the applicable requirements of the relevant Chapters of the latest valid revision of the following RINA Rules:

RINA RES.17	Rules for the Classification of Floating Offshore Units at Fixed Locations and Mobile Offshore Drilling Units
RINA REP.1to6	Rules for the Classification of Ships

are to be complied with. Moreover, in the following Table 1 it is reported for general reference a list of International Standards including acceptable methods and useful guidance to supplement the contents of this Guide. When applicable, detailed provisions are reported in the Guide with specific reference mentioned. The most updated revision of each reference document is to be applied.

SECTION 1 – GENERAL PRINCIPLES

Table 1: Reference International Standards

Code Number	Code Title
IEC EN 61400-3	Wind Turbines, Part 3: Design requirements for offshore wind turbines
IEC EN 61400-1	Wind Turbines, Part 1: Design requirements
EN 1993-1-1	Eurocode 3 – Design of Steel Structures – Part 1.1: General Rules and Rules for Buildings
EN 1993-1-6	Eurocode 3 – Design of Steel Structures – Part 1.6: Supplementary Rules for the shell structures
EN 1993-1-8	Eurocode 3 – Design of Steel Structures – Part 1.8: Design of joints
EN 1993-1-9	Eurocode 3 – Design of Steel Structures – Part 1.9: Fatigue
EN 1993-1-10	Eurocode 3 – Design of Steel Structures – Material toughness and through-thickness properties
EN 1997-1	Eurocode 7 – Geotechnical design – Part 1: General Rules
EN 1998-1	Eurocode 8 - Design of structures for earthquake resistance
EN ISO 19900	Petroleum and natural gas industries — General requirements for offshore structures
EN ISO 19901-1	Petroleum and natural gas industries – Specific requirements for offshore structures – Part 1: Metocean design and operating conditions
EN ISO 19901-2	Petroleum and natural gas industries – Specific requirements for offshore structures – Part 2: Seismic design procedure and criteria conditions
EN ISO 19901-4	Petroleum and natural gas industries – Specific requirements for offshore structures – Part 4: Geotechnical and foundation design considerations
EN ISO 19901-5	Petroleum and natural gas industries – Specific requirements for offshore structures – Part 5: Weight control during engineering and construction
EN ISO 19901-6	Petroleum and natural gas industries — Specific requirements for offshore structures — Part 6: Marine operations
EN ISO 19901-7	Petroleum and natural gas industries — Specific requirements for offshore structures — Part 7: Stationkeeping systems for floating offshore structures and mobile offshore units
UNI EN ISO 19904-1	Petroleum and natural gas industries — Floating offshore structures – Part 1 : Ship-shaped, semi-submersible, spar and shallow-draught cylindrical structures
UNI EN ISO 19904-2	Petroleum and natural gas industries — Floating offshore structures – Part 2 : Tension Leg Platforms
API RP 2T	American Petroleum Institute – Recommended Practice for Planning, designing and Constructing Tension Leg Platforms
API RP 2SK	American Petroleum Institute – Recommended Practice for Design and Analysis of Stationkeeping Systems for Floating Structures
BS 7910	Guide on methods for assessing the acceptability of flaws in metallic structures
IMO	International Maritime Organization – SOLAS 1974 and Following Amendments - Safety of Life at Sea
NACE RP0176-83	NACE Standard Recommended Practice – Corrosion Control of Steel Fixed Offshore Platforms
BS 7361	British Standard Institute – Cathodic Protection Part 1. Code of Practice for Land and Marine Applications
Marpol Agreement	International marine regulations on trash and water effluents
ISO/PAS 20858:2004	Ships and marine technology – Maritime port facility Security assessment and security plan development

SECTION 1 – GENERAL PRINCIPLES

4.4 Basis of design for certification

The requirements of this Guide are to be applied together with those of recognised design codes or standards for the certification purpose.

In the case of discrepancies between the requirements of codes or standards used and those of this Guide, RINA may accept the former provided that, in its opinion, they ensure a global safety level equivalent to or higher than that resulting from the application of this Guide. Preference will generally be given to codes or standards developed and used in the country where the wind farm is to be installed.

Supplementary codes or standards used in the design are to be submitted to RINA for prior approval, and listed in a document identified as Basis for Design of the Floating Offshore Wind Turbine Installation that will be basic reference for the certification of compliance of the project (see 1.2.2).

5 Recognized certification schemes

Offshore wind turbines are typically designed according to the safety classes introduced by IEC 61400-3, Subclause 5.3.

Wind turbine classes are defined in terms of wind speed and turbulence parameters (V_{ref} and I_{ref}).

Offshore wind turbines require wind turbine “class S” design, in which the design value shall be chosen by the designer and specified in the design documentation (ref. IEC 61400-3, Subclause 6.2).

For a given wind class, IEC 61400-22 addressed a first type of certification, the type certification regime, which is strictly relevant to the wind turbine design (including

rotor, nacelle, assembly and tower), consisting of modulus that include:

- Design basis (prepared by manufacturer, including design assumptions, specific standards, technical requirements, etc.) evaluation;
- Wind turbine evaluation;
- Type testing;
- Manufacturing evaluation;
- Final evaluation,

while support structure design and manufacturing was an option (inside the type certification regime), a choice addressed by onshore applications where fixed in land foundation were considered not a critical issue.

For offshore plants the support structure is an integral element of the whole system and critical to aspects of the installation, therefore the second type of certification addressed by IEC 61400-22 – the Project certification – becomes suggestable.

The project certification encompasses the whole design plant, including the application of the site specific conditions and the support structure.

However also this type of certification, as originally addressed by IEC 61400-22, relies on IEC 61400-3 that is provided for fixed offshore wind turbine installations.

Floating support structures may have significant translational and rotational motions with respect to fixed offshore structures and these motions interaction with wind and wind turbine operability are not covered within the scope of the mentioned IEC certification process.

It is worth noting that the whole process is under review by IECRE (ref. IECRE OD 501 and OD 502), and a new IEC standard, addressing floating wind turbines peculiarities, is underway.

SECTION 2 – TERMS AND DEFINITIONS

1 Introduction

The single unit of a floating offshore wind farm is the floating offshore wind turbine (FOWT), defined as a wind turbine with a floating support structure subject to hydrodynamic loading (see Fig 1, where semi-sub floating installation is represented for instance).

Figure 1: Floating Offshore Wind Turbine Installation (semi-sub)



In general, the OWT installation can be split into the two following components:

- The rotor-nacelle assembly;
- The support structure,

for the main purpose of the assessment to the acting external loads, by considering however relevant interaction effects.

This Guide is addressing site-specific design of the floating offshore support structures and relevant stationkeeping system, while it is not addressing the specific design of the rotor-nacelle assembly (see also [1.1]), to the extent that this system is not affecting the response of the floating offshore wind turbine installation to the external environmental loads.

Therefore the definitions of the wind turbine components in [2.1] are reported for the purpose of this Guide.

2 Definitions

2.1 Wind Turbine

Wind turbine generates electricity by harnessing the power of the wind. The energy in the wind turns the blades around a rotor, that is connected to the low-speed shaft, which is the main. The drive train is made of the gears and increases the rotational speed. The high-speed shaft is connected to a generator that creates electricity.

The power generated by a wind turbine is based on the Rankine-Froude theory.

2.2 Rotor-nacelle assembly

The RNA is the part of a wind turbine carried by the support structure and it includes rotor and nacelle.

The rotor is constituted by the blades (generally three) and by the hub.

The nacelle, instead, is constituted by the turbine elements which are not part of the rotor, ie the transmission unit (shaft, coupling, transmission, brake and generator) and the coating of the nacelle itself.

2.2.1 Rotor

The rotor is the part of the wind turbine consisting of the blades and the hub.

2.2.2 Nacelle-assembly

The nacelle-assembly is the collection of all components above the tower that are not part of the rotor.

This includes, principally, the drive train (shafts, couplings, gearbox, generator and brakes) and the nacelle enclosure.

Figure 2: Schematic representation of the rotor-nacelle group

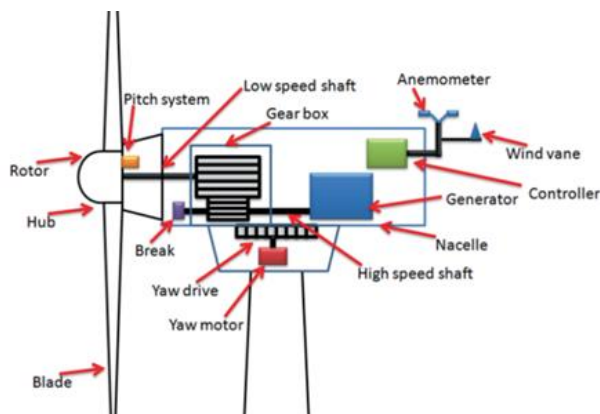

SECTION 2 – TERMS AND DEFINITIONS

2.3 Support structure

It is the portion of the offshore wind turbine installation made by the tower, the floating support structure and the stationkeeping system.

2.3.1 Tower

Structural component, which forms a part of the support structure for a wind turbine, usually extending from a section above the still water level to just below the nacelle of the wind turbine.

2.3.2 Floating Support Structure

The floating support structure is the part of the offshore wind turbine installation that is specifically submerged along the water depth, since it extends upwards from the seabed, connecting the foundation to the tower. Different floating support structure concepts exist and they are further characterized in the following item [3].

2.3.3 Stationkeeping system

The stationkeeping system is the system designed to maintain the floating support structure in a fixed location. It includes the mooring lines or tendons, depending on the floater’s type, and the anchoring foundation system, which is designed to transfer the mooring forces to the seabed.

2.4 Design life

The period of time between the commencement of construction and removal or final disposal of the wind turbine installation, which may be subdivided into the following phases:

- Construction phase. This phase includes construction and assembly of the structure ashore or afloat;
- Transportation phase. This phase includes transportation of the structure or parts thereof, from the construction site to its final location;
- installation phase. This phase includes possible marine operations relevant to the installation of the unit at its final location, such as submerging and positioning of the floating structure, mooring system installation, anchoring, ballasting, arrangements of nacelle, rotor, blades or other modular components,

cable laying, until the unit is ready to start its normal service operation;

- Operation phase. This phase starts with completion of installation and ends with removal of the structure;
- Removal phase. This phase includes decommissioning of the plant, removal of the structure from its location at the end of its operation and final disposal.

2.5 Location

The geographical location where the floating offshore wind turbine installation is finally installed to perform its design operation.

2.6 Water depth

The vertical distance from the sea bed to the minimum water level taking into account the effects, combined as necessary in the evaluation of the loads, of astronomical, wind and pressure differential tides.

3 Floating Support Structures Characteristics

In the specific case of floating wind turbine installations, the support structure is the floating body that is designed to withstand the weight of the entire wind turbine.

The support structure may be classified based on the main approach adopted to answer the static stability requirements in the rotational degrees of freedom (pitch and roll), for example how the structure counteracts the inclining moment due mainly to the aerodynamic forces acting on the wind turbine.

In the following Fig 3 an example of three main type of floating turbine concepts with relevant stability features is provided.

In this guide four main types of floating support structures (see Fig 4), relevant to the actual state-of-the-art, are considered:

- Barge
- Semi-submersible
- Spar
- Tension Leg Platform (TLP)

Figure 3: Principal floating turbine concepts

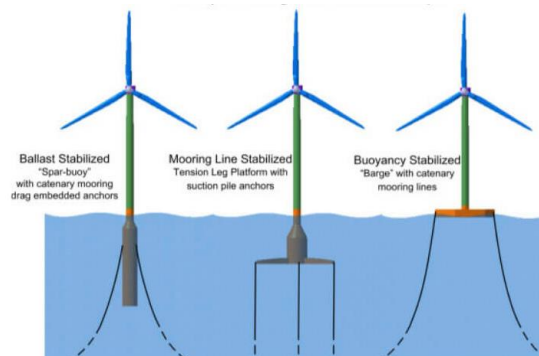

SECTION 2 – TERMS AND DEFINITIONS

Figure 4: Types of Floating Offshore Wind Turbine Structures

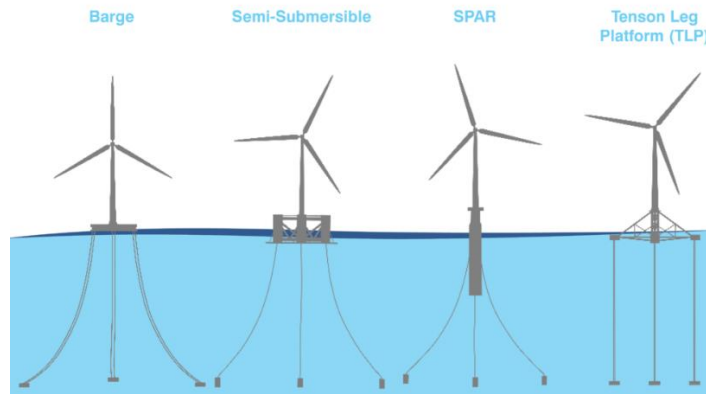

Further ‘mixed’ or innovative solutions may be considered, based on the criteria outlined in Section 1, [3].

In any case the floating structures is to be kept in position by the station keeping system provided by mooring lines or tendons and relevant foundation to the seabed.

The choice of the support structure type is a function of different parameters such as construction and installation costs, site environmental conditions (such as water depth) etc.

3.1 Column stabilized Floating Support Structure

A column stabilized floating support structure mainly consists of a floating structure made by a topside deck connected to the underwater hull by columns, horizontally framed by bracings.

The floating support structure depends on the buoyancy of the columns for floating stability, in addition to the contribution of lower hulls or footings. The tower may be connected directly to the column or to the topside deck structure.

3.2 Spar type Floating Support Structure

A spar is a type of floating support structure (typically used for oil&gas production in very deep waters). It is a neutrally buoyant structure (which allows six-degrees of freedom). Its concept is a deep draft, cylindrical tower designed to support the tower and any topside structure. Its buoyancy can support facilities above the water surface. It is anchored to the seafloor by conventional mooring lines.

The bottom of the cylinder includes a ballasting section with material that weighs more than water, ensuring the center of gravity is located below the center of buoyancy.

3.3 TLP type Floating Support Structure

A TLP is a type of floating support structure, introduced for oil&gas production in deep waters, from 300 up to 1500 meters.

TLP FOWT may be used at sites with shallower waters sites (even shallower than 100m) depending on relevant economics and suitability.

It is a positively buoyant compliant platform, vertically moored by tethers, maintained in tension by the excess buoyancy of the platform; as such, it is vertically restrained precluding motions vertically (heave) and rotationally (pitch and roll), while it is typically compliant in the horizontal direction permitting lateral motions (surge and sway), even if some TLP systems may also provide lateral restraint.

A TLP-type floating support structure mainly consists of a floating hull, a base anchored to the bottom (rest position), anchoring tethers (typically steel pipes, can also be chain, synthetic, steel wire), which are usually from 3 to 6 per leg, that must remain in tension even when the platform is in the highest wave trough or earthquake (limited compression may be allowed for ALS conditions provided instability to Mathieu mechanism is not triggered). Typical heave periods are between 2 and 5 seconds and typical surge periods between 100 and 130 seconds.

3.4 Degree of Freedom

The degrees of freedom for a floating wind turbine is reported in Fig 5 (represented, e.g. for a spar-type floating support structure), where

- Surge: Displacement along the longitudinal axis (along with the acting wind direction);
- Roll: Rotation about the longitudinal axis;
- Sway: Displacement along the lateral axis;
- Pitch: Rotation about the lateral axis;
- Heave: Displacement along the vertical axis;
- Yaw: rotation about the vertical axis.

In general, among the different types of floating support structures, barges, semisubmersibles and spars are all compliant with respect to the six degrees of freedom, while TLPs are typically compliant for surge, sway and yaw, and restrained for heave, roll and pitch.

SECTION 2 – TERMS AND DEFINITIONS

Figure 5: Degrees of freedom of Floating Wind Turbine Installation



Note – Alignment of surge, sway and heave with wind direction shown in the figure is not relevant for the correct definition of the 6-DOF coordinate system that is to be based on the floating body, equivalent to definitions relative to a ship

SECTION 3 – SAFETY PHILOSOPHY AND DESIGN PRINCIPLES

1 Safety Philosophy

1.1 Structural safety requirements

Offshore wind turbine structures are to be realised so as to ensure an acceptable level of safety with respect to the life at sea, the prevention of environmental pollution and possible major economic losses during all phases of the design life.

A support structure, and relevant stationkeeping system, is considered to have an acceptable level of safety when it is designed, constructed and maintained in compliance with the requirements of this Guide and with those of supplementary codes mentioned in Section 1.

1.2 Risk exposure levels

1.2.1 Determination of exposure level categories according to ISO Standard

According to a recognized risk based design philosophy (see e.g. ISO 19902), offshore installations can be categorized by different exposure levels, according to which assessment criteria tailored to the intended service of the installation are determined.

Three levels of exposure are determined (specifically for oil&gas production platforms, ref. Subclause 6.6 ISO 19902:2007) in consideration of:

- Life safety categories:
 - S1 : Manned non-evacuated;
 - S2 : Manned evacuated (*);
 - S3 : Unmanned,
- Failure consequence categories:
 - C1 : High consequences;
 - C2 : Medium consequences;
 - C3 : Low consequences.

() Note for the seismic structural assessment, where applicable, S2 is to be reported as S1 (manned non-evacuated). Consequently, for the seismic risk categories, manned platforms are all categorized with exposure level L1.*

In order to select the appropriate category for both life safety and failure consequence, the criteria applicable for oil&gas offshore platforms are those of ISO 19902, Subclauses 6.6.2 and 6.6.3 respectively.

Three exposure levels are therefore determined as a combination of the two sets of categories as reported in the following Tab 1:

Table 1: Exposure Level determination.

Life Safety Category	Consequence Category		
	C1	C2	C3
S1	L1	L1	L1
S2	L1	L2	L2
S3	L1	L2	L3

1.2.2 Determination of exposure level categories for Floating Offshore Wind Turbine Installations

In general:

- The applicable exposure level is to be determined by the owner prior to the design of a new offshore installation (or the assessment of an existing one), and the structure will be certified accordingly.
- The assigned exposure level can be modified during the service life, following to modification in the installation characteristics that affect life safety and/or consequence category.

For floating offshore wind turbine installations, being it unmanned during severe environmental conditions and the structural failure is unlikely to lead to unacceptable consequences for the environment, an exposure level L3 may be the general reference for targeting the safety (see 1.2.3) in the design of both the floating support structure and the stationkeeping system, provided that this latter is a redundant system. For stationkeeping systems without redundancy, in the design of their

components the exposure level L2 is to be used as reference for the safety target.

1.2.3 Notional safety targets

A notional target safety level may be established as annual probability of failure of the entire structure, being also the reference target safety level for individual failure mode, intended for use both in case of local failure in hot spots and in case of failure with system effects, such as failure in the weakest link of a mooring line.

The notional annual probability of failure of 10⁻⁴ is the target safety level for the structural design of floating wind turbine support structures with redundant stationkeeping system. In case of non redundant stationkeeping system this target, which reflects a commonly acceptable level of risk, is to be reduced to 10⁻⁵.

In practice, the target safety level is established to calibrate relevant partial safety factors when a LRFD – Load and Resistance Factors Design - format is adopted for the structural design, as in general

SECTION 3 – SAFETY PHILOSOPHY AND DESIGN PRINCIPLES

foreseen in this Guide (apart from the case of mooring lines components where the WSD – Working Stress Design - format is still custom normal practice).

Example application of the LRFD method, compared to the WSD method, with relevant general principles for partial safety factors calibration is further reported in item [3].

1.3 Robustness requirement

In any case, above reported notional reference values are to be used for structures with some reserve capacity (i.e. structures with some ductility), correctly designed and fabricated without systematic or gross human errors.

Gross human errors are to be coped with by the application of an appropriate quality control plan and relevant third party inspections, to be applied during the entire design and fabrication process of the offshore installation.

This is indeed the main objective of the certification activity, that is to provide for robustness against possible systematic errors in the design, particularly for novel floater concepts and technologies, whose design is not yet covered by standard practice.

1.4 Design assisted by model tests

Model tests are to be used in general to validate the analytical design methods and, more specifically, to validate software and checks for the floating wind turbine installation response to external actions whose effects are not adequately covered by analytical methods.

Design assisted by model tests is particularly recommended for novel designs.

1.5 Functional requirements

The serviceability of the platform, i.e. the aptitude of the platform to be properly operated in performing its design service, may require special design criteria.

The Designer or the Owner may specify functional requirements which are additional to those of this Guide.

2 DESIGN PRINCIPLES

2.1 Methods of analysis and calculation

2.1.1 General

The safety verification of the wind turbine structure is to be performed by checking that stresses and structure dynamics do not exceed specified limit values.

For the structural capacity adequacy, it has to be verified that the stresses, generated by the different loads acting on the offshore installation, are not exceeding the resistance levels of the structural components that are to be defined with reference to a specific set of limit states.

Four categories of limit states are typically considered (see also ISO 19900):

- Ultimate limit states (**ULS**), which generally correspond to the resistance to maximum applied actions;
- Serviceability limit states (**SLS**), which correspond to the criteria governing normal functional use;
- Fatigue limit state (**FLS**), which corresponds to the accumulated effect of repetitive actions;
- Accidental limit states (**ALS**), which corresponds to situation of accidental or abnormal events.

For each limit state, design situation shall be determined and an appropriate calculation model shall be established.

2.1.2 Determination of loading effects

The determination of forces, moments, stresses and strains as well as the definition of corresponding limit values are to be based upon accepted principles of static analysis, dynamic analysis and strength of materials.

The determination of loading effects is to be based on the theory of elasticity.

Methods based on the theory of plasticity will be specially considered by RINA.

Physical and mathematical models used to analyse the structure and the idealisations of structures and of loadings are to be deemed acceptable by RINA and are to simulate and describe satisfactorily the behaviour of the actual structure and the anticipated relevant environmental conditions.

Possible effects of non-linearity in the geometry or materials which may significantly affect the safety of the structure are to be carefully considered.

The influence of geometrical imperfections on the behaviour of the structure is also to be considered.

The effects of cyclic loads, which may cause damage due to fatigue, are to be determined in terms of magnitude and number of cycles; i.e. a long term distribution analysis of alternate stress magnitudes on the basis of the stress fluctuation anticipated during the design life of the structure.

The dynamic effects of cyclic loads, including motions and local vibrations caused by vortex shedding phenomena, are to be considered.

Dynamic loading effects are to be determined using recognised methods of analysis and realistic assumptions about wind loads, hydrodynamic and material properties and analytical models.

Linear and nonlinear loads and loading effects are to be taken into account.

2.1.3 Model tests

Tests on models which satisfactorily simulate the behaviour of the platform or parts thereof, carried out by recognised laboratories, may be used as an alternative to or together with theoretical calculations.

SECTION 3 – SAFETY PHILOSOPHY AND DESIGN PRINCIPLES

Such model tests may be required by RINA as a basis for approval of structural details for which adequate analytical models are not available.

Model tests can be used either as calibration of analytical predictions, or to determine those responses not directly calculable.

When using results of model experiments which include either hydrodynamic or aerodynamic loadings, the following should be considered:

- possible errors due to scale effect (including effects of Reynolds Number dependent viscous effects);
- possible errors resulting from finite tank dimensions (wave reflection from side walls);
- possible errors resulting from limitations of the accuracy of modelling physical properties, parameters and dimensions;
- limitations on accuracy of experimental results due to finite record lengths, finite sample rates and numerical accuracy.

2.1.4 Monitoring systems

Besides data measurements system relevant to the wind turbine operational performance, a monitoring system is recommended to be mounted on substructure in order to gain significant information regarding the actual structural response of the installation, which significantly improve the structural reliability by providing continuous data relevant to the actual response of the structure.

Such monitoring system would be useful to provide either an active control relevant to any occurred significant variation in mass or stiffness of the structure or, through adequate filtering evaluation, updated measures of the platform's natural frequency, which, in turn, is the basis for any further fatigue evaluation required for reassessment or extension life task.

In addition to the structural monitoring system, a meteorological data measurement system may be considered as suitable to be installed on the support structure since the early phases of its operating life, capable to record meteorological and marine data, such as:

- Directional wave motion;
- Current velocity and direction;
- Sea level variation,

useful for a following revision of statistics of wave, wind and current data with actual characterization of the meteorological loads acting on the wind farm units.

All the above is also recommended to facilitate possible extension of the service life of the structures.

2.2 Design criteria

2.2.1 General

Wind turbine structures are to be designed so as to minimise their sensitivity to environmental factors and service loads, and to facilitate their construction and inspection.

The design of the structure as a whole and of its components is to be such that normal operational condition is not impaired by structure motions and vibrations.

Structures which are subject to forces from mooring lines are to be designed to withstand the breaking load of such lines.

Due consideration is to be given to corrosion and adequate protection systems against corrosion are to be carefully examined in relation to the environmental parameters and expected service life.

Secondary structures such as fenders, gangway ladders, etc. , if any, are to be designed so that possible failure due to accidental overload will not result in damage to the main structure or injury to personnel.

Structural connections and joints are to be designed, as far as practicable, to avoid complex structures and sharp section variations which may give rise to dangerous stress concentrations.

Transmission of primary tensile stresses through the thickness of plates is also to be avoided as far as practicable.

Where this is not practicable, the use of plates with through thickness properties is generally recommended.

Wind turbines support structures constructed to be operated in locations where low temperatures may occur are to be designed to avoid configurations which may give cause to ice accumulation on structures and equipment.

Possible impacts of floating blocks of ice against the structures located in the splash zone are also to be considered.

Appropriate properties for steel material are to be selected depending on the lowest operating temperature foreseen at installation site, regarding in particular material toughness and/or resilience to avoid brittle fracture mechanisms in primary structures.

The relevant requirements of the RINA Rules for ships apply to secondary structures of typical naval design (tanks, deckhouses, etc.) which do not participate in the global strength of the hull and are subject to local loads only.

2.2.2 Protection against accidental damage

The structural configuration is to be designed taking account of the possibility of accidental damage.

In order to protect the structure against accidental damage, the following two principles are to be considered:

- Reduction in damage probability;
- Reduction in damage consequences.

2.2.3 Accessibility for inspection

The support structure is to be designed to minimise the number of structural members which are not accessible for inspection and repair.

For structural members which are not accessible for inspection, RINA may specify additional more stringent

SECTION 3 – SAFETY PHILOSOPHY AND DESIGN PRINCIPLES

requirements concerning their strength (particularly with respect to the fatigue limit state) and the maintenance of their original functional characteristics.

2.3 Reassessment of existing structures

An assessment of an existing floating wind turbine installation is to be undertaken with relevant certification if any of the following initiators are triggered:

- Changes from original design basis or from previously certified assessment basis;
- Damage or deterioration of the primary structure, due to an abnormal event, unpredictable at original design basis;
- Design service life exceedance, with particular attention paid to time-dependant degradation phenomena (i.e. fatigue and/or corrosion).

When an initiator is triggered, the reassessment process of the structure of an offshore platform is to be carried out, based on the criteria used for the assessment of existing offshore steel structures (ref., e.g., RINA Rules for Steel Fixed Offshore Platforms, Part B, Chapter 6) as applicable.

2.4 Structure reuse

Structures that are to be removed or reused in a new location different than the original design site are to be subject to a verification process that, in addition to the general requirements addressed by this Guide, is also covering:

- Fatigue assessment for reused structures;
- Steel properties requirements in reused structures;
- Inspection requirements for reuse and removal;
- Removal and reinstallation requirements;
- Inspection and structural integrity management plan at new location.

3 APPENDIX A3 – LRFD FORMAT BASIC PRINCIPLES

3.1 WSD vs LRFD

The design format used in the offshore industry up to the late 90s has been the WSD (*Working Stress*

Design) format, leading to the required safety level, in consideration of the uncertainties relevant to load and resistance parameters affecting the design, by introducing a common safety factor SF, greater than 1, in the typical equation check:

$$\sigma (F) \leq \sigma_{adm} = \frac{\sigma_{lim}}{SF}$$

where $\sigma (F)$ is the stress due to the application of the resulting loads, which are typically categorized for an offshore structures in *dead*, *live* and *environmental*, and σ_{adm} is the allowable stress σ_{lim} , i.e. the strength corresponding to a specific limit state, derated by SF.

This format is subject to criticism, particularly for non-elastic limit states, or for structural components stressed by loads of different randomness. A more rational approach would be the one able to characterize the specific probabilistic features of all the parameters, relevant to loads and resistance, eventually affecting the reliability of the structure. As mentioned above, loads may be categorized in:

- Dead loads (i.e. permanent gravitational loads);
- Live loads (i.e. variable gravitational loads);
- Environmental loads (i.e. due to environmental loads such as wind, wave, current, earthquake, etc.).

While the first two categories are of limited variability, the environmental load, of random nature, are highly aleatory, therefore an approach able to ‘weigh’ the different contribution, in terms of uncertainty, to the final safety level (or safety target) required for structures designed to withstand these different load categories (rather dominated by environmental loads to some extent) would be more appropriate.

Indeed the safety check is aimed at ensuring that, given the jointly statistical distribution of load and resistance, see Fig 1, the probability of overcoming a given (for instance, the strength) limit state is lower than the prescribed safety target, established in terms of probability of failure p_{ft} .

Figure 1

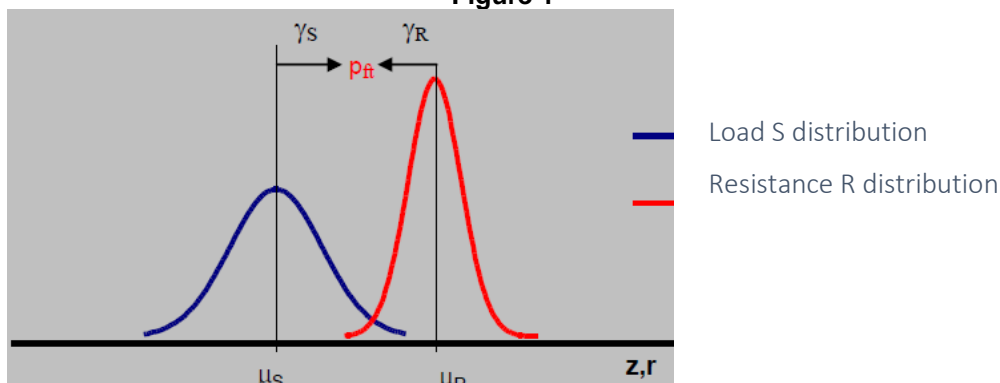

SECTION 3 – SAFETY PHILOSOPHY AND DESIGN PRINCIPLES

Since a fully probabilistic method is impracticable, it has been introduced in design codes a semi-probabilistic approach, where the safety target is implicitly conferred by the adoption of partial load and resistance safety factors (LRFD format), specifically calibrated (via reliability methods) on respective uncertainties.

In a LRFD format the safety condition $p \leq p_f$ is finally provided by the following typical check equation:

$$S (\sum_i \gamma_i F_{iK}) \leq R_k / \phi$$

where S is the loads effect of the combined characteristic loads F_{iK} duly amplified by the *partial load factors* γ_i ($\gamma_i \geq 1$), and R_k is the characteristic value of the resistance, duly reduced by the partial resistance factor ϕ ($\phi \geq 1$).

In the case of the three load categories introduced above, the equation check is typically written as:

$$S (\gamma_D D + \gamma_L L + \gamma_E E) \leq R_k \Phi_{Ri}$$

where the resistance factor is introduced with a value $\Phi_{Ri} \leq 1$, depending on the specific limit state under verification.

The partial safety factors are calibrated to the specific uncertainty of the parameter they are applied to, eventually resulting in a more balanced and optimal design, with respect to the WSD method, since the needed conservativity is distributed where appropriate, i.e. where relevant uncertainties are more addressing the final design.

Each partial safety factor value, to be applied at a given design parameter, is to be calibrated on the uncertainty relevant to such a parameter (typically represented by a statistical distribution coefficient of variation), with the final purpose of duly contributing to the global safety target of the structure, which is basically expressed as annual probability of failure (acceptable risk level established by considering relevant failure consequences, as discussed in Section 3, [1.2]), with the notional values of, e.g., 10^{-4} - 10^{-5} , reported in [1.2.3] for floating offshore wind turbine installations.

The partial safety factors calibration process is the background basis of any modern LRFD format design codes (such as ISO, Eurocodes, API-LRFD, etc.) and relevant features are outlined in the following [3.2].

3.2 Outline procedure for determination of the Partial safety factors

The partial safety factors may be determined by a level 2 reliability method when the required safety level (safety target) for the check condition is expressed by the following relationship:

$$p_f = \Phi(-\beta)$$

where β is the safety index corresponding to the given

p_f (via Φ that is the normal cumulative distribution function), and the limit state function (or safety check equation) is represented as:

$$M = g(x_1, x_2, \dots, x_n),$$

Where:

- M is the safety margin and
- x_i are the random variables contributing to the different load and resistance parameters;

The limit state function $g(\cdot)$ is a function that provides the relation between these parameters and the specific limit state under verification, maybe a ULS or a SLS condition.

$M > 0$ is representing a safe condition, $M < 0$ a failure condition and $M = 0$ is the limit state equation.

The *partial safety factors psf's* γ_i (or *load and resistance factors – LRF*) are the factors that, when multiplying the design variables x_i , provide the required reliability level β .

Then the limit state function may be reported as:

$$g(\gamma_1 \mu_{x_1}, \gamma_2 \mu_{x_2}, \dots, \gamma_n \mu_{x_n}) = 0$$

where γ_i are the psf's and μ_{x_i} are the average values of the design variables.

According to a level 2 reliability method the reported equation is representing a failure surface, which the different variables $\gamma_i \mu_{x_i}$ belong to; in particular they represent the most probable failure point on that surface:

$$\gamma_i = \frac{x_i^*}{\mu_{x_i}}$$

where:

$$x_i^* = -\alpha_i^* \beta \quad \text{and} \quad \alpha_i^* = \frac{\left(\frac{\partial g}{\partial x_i} \right)_*}{\sqrt{\sum_i \left(\frac{\partial g}{\partial x_i} \right)_*^2}}$$

By introducing the definition of standardized normal variables:

$$x_i^* = \frac{x_i^* - \mu_{x_i}}{\sigma_{x_i}},$$

it is shown that:

$$\begin{aligned} x_i^* &= \mu_{x_i} + \sigma_{x_i} x_i^* = \mu_{x_i} - \alpha_i^* \beta \sigma_{x_i} \\ &= \mu_{x_i} (1 - \alpha_i^* \beta \cdot v_{x_i}) \quad \text{where } v_{x_i} = \frac{\sigma_{x_i}}{\mu_{x_i}} \end{aligned}$$

and the psf's may be finally determined by:

$$\boxed{\gamma_i = 1 - \alpha_i^* \beta \cdot v_{x_i}} \quad (A.3)$$

As shown in the formula (A.3), each psf γ_i to be applied to a given design parameter x_i is a function of the prescribed safety target β , of the statistical variation of that parameter (in terms of coefficient of variation v_{x_i})

SECTION 3 – SAFETY PHILOSOPHY AND DESIGN PRINCIPLES

and sensitivity factors α_i^* that are calculated by numerical reliability methods for the given failure equation.

For instance, in the case of linear limit state function, the equation:

$$g(\gamma_1\mu_{x_1}, \gamma_2\mu_{x_2}, \dots, \gamma_n\mu_{x_n}) = 0$$

may be written as

$$g(\underline{x}) = a_0 + \sum_{i=1}^n a_i x_i$$

or

$$a_0 + \sum_{i=1}^n a_i \gamma_i \mu_{x_i} = 0$$

and the partial derivatives $\frac{\partial g}{\partial x_i}$ are independent of x_i , i.e:

$$\frac{\partial g}{\partial x_i} = a_i \sigma_{x_i}$$

(given that $x_i = \sigma_{x_i} x'_i + \mu_{x_i}$)

Therefore:

$$\gamma_i = 1 - \frac{a_i \sigma_{x_i}}{\sqrt{\sum_{i=1}^n (a_i \sigma_{x_i})^2}} \cdot \beta \cdot v_{x_i}$$

For example, in the case of the simple linear function, where the safety margin is represented by the difference between the two parameters, global strength S and global resistance R:

$$M = g(x_1, x_2) = R - S$$

Given the target $\bar{\beta}$ and the two variables reported in normalized form:

$$R' = \frac{R - \mu_R}{\sigma_R} \quad S' = \frac{S - \mu_S}{\sigma_S}$$

$$M = R - S' = \sigma_R R' + \mu_R - \sigma_S S' - \mu_S$$

$$\frac{\partial M}{\partial R'} = \sigma_R \quad \frac{\partial M}{\partial S'} = -\sigma_S$$

$$\alpha_R = \frac{\sigma_R}{\sqrt{\sigma_R^2 + \sigma_S^2}} ; \quad \alpha_S = \frac{-\sigma_S}{\sqrt{\sigma_R^2 + \sigma_S^2}}$$

$$\gamma_R = 1 - \alpha_R \bar{\beta} v_R = 1 - \bar{\beta} v_R \frac{\sigma_R}{\sqrt{\sigma_R^2 + \sigma_S^2}}$$

$$\gamma_S = 1 - \alpha_S \bar{\beta} v_S = 1 + \bar{\beta} v_S \frac{\sigma_S}{\sqrt{\sigma_R^2 + \sigma_S^2}}$$

Resulting in values $\gamma_R < 1$ and $\gamma_S > 1$, which can be easily evaluated for given safety target and standard deviations (representing their variability) of the two variables.

The two relevant partial safety factors are obtained by:

SECTION 4 – ENVIRONMENTAL CONDITIONS

1 General

1.1 Environmental phenomena

The design of the floating wind turbine structure shall be based on site-specific external conditions, where all environmental phenomena that may produce loads acting on the structure are to be considered.

Such phenomena include wind, waves, currents, tides, temperature, ice, marine fouling earthquakes.

It shall be demonstrated that the offshore site-specific external conditions do not compromise the structural integrity of the wind turbine installation.

For the determination and use of metocean conditions to be used for design, installation and operation of offshore structures general reference can be made to ISO 19901-1, Metocean design and operating considerations.

The salinity and biological activity of the water are to be considered in the evaluation of marine fouling increase and in the choice of the protection system against corrosion, where applicable.

For the sea bed and soil layers underneath, see Section 10, [3.2].

1.2 Acceptability of the parameters defining the design environmental conditions

The parameters defining the design environmental conditions for which the wind farm is to be certified are to be based, where possible, on significant statistical information regarding the geographical areas where the floating support structures are to be constructed, transported and installed; such statistics are to cover a sufficiently long period of time and to be supplied by recognised meteorological-oceanographic institutes.

Floating support structures expected to be mass production units may be designed for a given environmental class, meaning that similar environmental conditions are grouped based on an envelop of all wind and wave climates encountered in the region of application.

In any case the stationkeeping system is to be designed for the specific site interested by the mooring configuration (see Section 10).

All data are to be supplied by recognised meteorological-oceanographic institutes and are to be fully documented with the sources (measurements, calculation by means of mathematical models) and estimated reliability of data.

When the above-mentioned environmental parameters are based on extrapolated data or on forecasting methodologies other than those commonly used, sufficient theoretical information is to be supplied to RINA in order to demonstrate their reliability.

1.3 Determining parameters relevant to the design environmental conditions

The environmental phenomena are to be described by those characteristic parameters which are most

significant for the evaluation of the effects of the environment on the structures.

In general, such parameters shall provide characterization of (making also reference to ISO 19901-1, Subclause 5.1):

- Extreme values of environmental parameters corresponding to return periods appropriately longer than the time of exposure of the floating wind turbine installation, or main component thereof, in a given design situation;
- Operating environmental conditions which occur frequently during the service life of the floating wind turbine installation;
- Long term statistical distributions of metocean parameters affecting the structural response to time dependant limit state such as the fatigue limit state.

For a site-specific floating offshore wind turbine installation design for extreme, operating and temporary conditions, environmental data shall basically include extreme events of 50-, 10- and 1-year return period data for wind speeds, significant wave height and current. A range of associated wave periods is to be given for each considered significant wave height.

Both winter storms and tropical cyclones (hurricanes or typhoons), if any, are to be considered, depending on regional climate of the site specific application.

Guidelines

For tropical cyclone and hurricane provisions, to be applied particularly in the US waters, consideration should be given to the conclusions and recommendations reported in the document Assessment of Offshore Wind System Design, Safety and Operation Standard prepared by the National Renewable Energy Laboratory (NREL) at U.S. Department of Energy Office.

As basis for the design of the floating wind turbine installation's support structure and stationkeeping system, environmental data shall cover:

- directional data and angular separation for extreme values of wind, waves and current;
- wave scatter diagram assigning probability of occurrence to all sea states, characterised by a significant wave height and a wave period, which can be expected in the considered site of operation. The precision of the scatter diagrams is to be at least 10^{-5} corresponding to 20-years sea-state observations;
- definition of any adopted parameter characterizing sea-states and scatter diagrams;
- waves, wind and current joint probabilities (including relative directions);
- wave energy spectral shape formulation and spreading function, for both wind driven sea and swell (if any);
- wind spectrum and speed profile;
- current speed and directional variation through the water depth;

SECTION 4 – ENVIRONMENTAL CONDITIONS

- sea and air temperature;
- ice, iceberg and snow (if any);
- salinity;
- marine growth;
- soil properties;
- site seismicity;
- ship traffic and presence of obstacles (such as pipelines and disposed matter) within the area of installation.

Guidelines

As part of site-specific environmental data characterization for a floating wind structure, particular attention is to be paid to the characterization of the correlation between wave data and wind data, to be used for the fatigue assessment. That correlation may be expressed in terms of the joint long-term probability distribution for the significant wave height HS, the peak period TP (or the zero-upcrossing period TZ), the ten-minutes mean wind speed U10, the standard deviation of the wind speed sU, and can be represented in the form of a scatter diagram to be used for the spectral fatigue analysis.

This scatter diagram is also to be defined by considering the mean wave direction and the mean wind direction, being the misalignment between wind and waves relevant for the aerodynamic damping evaluation, affecting in turn the stress response. For most modes of motion, aerodynamic damping is significant only if the wave direction is in line with the rotor axis (which is usually in line with the mean wind direction), that's not the case for yaw motions, where aerodynamic damping remains high independently of the misalignment between wind and wave directions.

Probabilistic methods for short-term, long-term and extreme-value prediction are to be based on statistical distributions appropriate to the environmental phenomena being considered.

Shorter return periods may be considered for units with design life of 10 years or less.

For transit conditions, wind speed and significant wave height of 10-year return period may be considered as a standard reference (see also Sec 5, [2.5]).

For wind turbines located within a wind farm, local wake effects due to the presence of other wind turbines are to be considered. Low-frequency meandering wakes are to be considered in particular by making reference to IEC 61400-1 provisions.

2 Wind characterization

2.1 Wind Conditions

The wind regime for a wind turbine installation, according to IEC 61400-1, Subclause 6.3 is to be characterized as follows:

- Normal wind conditions that are assumed to occur more frequently than once per year during normal operation (ref. IEC 61400-1, Subclause 6.3.1);

- Extreme wind conditions that are defined with a 1-year or 50-year recurrence period (ref. IEC 61400-1, Subclause 6.3.2)

Normal wind conditions are representative of recurrent loading conditions (normally used for fatigue loads) while extreme wind conditions characterize extreme design loads.

2.2 Wind data

The parameters describing the wind conditions are to be obtained on the basis of wind velocity statistical data (intensity and direction).

The typical parameters characterizing the wind climate are:

- U_{10} : the 10-minute mean wind speed (referred to the conditions above mentioned).
- σ_U : the standard deviation of the wind speed.

The wind conditions include a constant mean flow combined, in many cases, with either varying deterministic gust profile or with turbulence.

In all cases, the inclination of the mean flow with respect to a horizontal plane is zero.

2.2.1 Mean Wind Speed

The wind speed at a height of 10 m above the mean still water level is to be used as a reference.

Extreme values of gust and mean (sustained) wind velocities are to be expressed in terms of most probable maximum values with their corresponding recurrence periods.

Guidelines

When data regarding the variation of mean wind velocity with height above the still water level (wind speed profile) is not available, the following formula may be used:

$$U_{10}(z) = U_{10}(H) \left(\frac{z}{H}\right)^{0.125}$$

In which:

$U_{10}(z)$: 1-hour wind mean speed at a distance z above still water level, in m/s;

$U_{10}(H)$: 1-hour wind mean speed at a distance H above still water level, in m/s;

z : distance from still water level to the point where the wind velocity $U_{10}(z)$ is to be calculated, in m;

H : distance from still water level to the point where the wind velocity is $U_{10}(H)$, in m;

2.2.2 Wind Modeling

The variation of wind speed in time shall be modelled using an appropriate spectrum. Such spectrum shall reproduce mean and gust velocities and durations in accordance with meteorological data.

U_{10} varies from one 10-minute timeframe to the next and this variability can be represented in terms of a Weibull distribution.

$$F_{U_{10}}(u) = 1 - e^{-\left(\frac{u}{\lambda}\right)^k}$$

SECTION 4 – ENVIRONMENTAL CONDITIONS

The slope parameter **k** and the scale parameter **A** are site and height-dependent coefficients.

Guidelines

For onshore plants, the scale parameter **A** at height **z** can be calculated as follows:

$$A = A_H \frac{\ln \frac{z}{z_0}}{\ln \frac{H}{z_0}}$$

z₀ is the terrain roughness parameter which is defined as extrapolated height at which the mean wind speed becomes zero (logarithmic variation with height adopted).

The sea surface roughness parameter is deeply analyzed in the following Clause G.2.2.2.

A_H is the scale parameter at a reference height **H**. For engineering calculation, the following approximation can be applied:

$$A = A_{10} \left(\frac{z}{H} \right)^\alpha$$

α depends on the terrain roughness. A height dependent expression for **α** is obtained if the logarithmic and exponential expressions for **A** given above are combined.

$$\alpha = \frac{\ln \left(\frac{\ln \frac{z}{z_0}}{\ln \frac{H}{z_0}} \right)}{\ln \frac{z}{H}}$$

As an alternative to the previous expression for **α**, values for **α** are tabulated below (provided for onshore plants terrain type):

Terrain type	z₀ [m]	α
Plane ice	0,00001	0
Coastal areas with onshore wind	0,001	0
Open onshore country (without significant buildings and vegetation)	0,01	0

G.2.2.2 Sea surface roughness parameter

For offshore locations where the terrain consists of the sea surface, the roughness parameter **z₀** is not constant, but depends on the wind speed, the height over the sea surface, water depth and wave field.

A widely used expression for the roughness parameter **z₀** of the open, deep sea far from land is given by Charnock’s formula:

$$z_0 = A_c \frac{(u^*)^2}{g}$$

where:

g = gravity acceleration (9,81 m/sec²)

A_c = 0,011

$$u^* = \sqrt{\frac{\tau}{\rho}}$$

u* is the frictional velocity, **τ** is the surface shear stress at sea surface and **ρ** is the air density.

Charnock’s formula can be applied to near-coastal locations provided that **A_c** = 0,034 is used.

Charnock’s formula leads to the following expression for the roughness parameter:

$$z_0 = \frac{A_c}{g} \left(\frac{\kappa U_{10}}{\ln \frac{z}{z_0}} \right)^2$$

The determination of **z₀** and of the distribution of **U₁₀** involves an iterative procedure.

Indicative values of the roughness parameter **z₀** are given in the following table.

Terrain type	z₀ [m]	α
Open sea without waves	0,0001	0
Open sea with waves	0,0001-0,003	0,12

2.2.3 Wind Speed Standard Deviation

For a given value of **U₁₀**, the standard deviation **σ_U** exhibits a natural variability of the wind speed from one 10-minute timeframe to another, known as turbulence. **σ_U** can be well-represented by a lognormal distribution:

$$F_{\sigma_U|U_{10}}(\sigma) = \Phi \left(\frac{\ln \sigma - b_0}{b_1} \right)$$

where **b₀** and **b₁** are site-dependent coefficients.

Guidelines

The coefficient **b₀** can be interpreted as the mean value of **ln σ_U** and **b₁** can be interpreted as the standard deviation of **ln σ_U**.

The mean value **E[σ_U]** and the standard deviation **D[σ_U]** can be calculated as follows:

$$E[\sigma_U] = e^{(b_0 + \frac{1}{2}b_1^2)}$$

$$D[\sigma_U] = E[\sigma_U] \sqrt{e^{b_1^2} - 1}$$

Since a lognormal distribution for **σ_U** conditioned by **U₁₀** may underestimate the higher values of **σ_U**, a more appropriate distribution model for **σ_U** is reported by the following Frechet distribution of **σ_U** conditioned by **U₁₀**:

$$F_{\sigma_U|U_{10}}(\sigma) = e^{-\left(\frac{\sigma_0}{\sigma}\right)^k}$$

The distribution parameter **k** can be solved implicitly and the distribution parameter **σ₀** using Gamma function **Γ**.

SECTION 4 – ENVIRONMENTAL CONDITIONS

$$\left(\frac{D[\sigma_U]}{E[\sigma_U]}\right)^2 = \frac{\Gamma\left(1 - \frac{2}{k}\right)}{\Gamma\left(1 - \frac{1}{k}\right)} - 1$$

$$\sigma_0 = \frac{E[\sigma_U]}{\Gamma\left(1 - \frac{1}{k}\right)}$$

Based on boundary-layer theory, the mean value of the standard deviation σ_U can be derived for homogenous terrain at height z .

$$E[\sigma_U] = U_{10} A_x \kappa \frac{1}{\ln \frac{z}{z_0}}$$

A_x is a constant that depends on z_0 .

A conservative fixed choice for σ_U is practical for design purposes, thus a characteristic value can be estimated as:

$$\sigma_{U,c} = U_{10} \frac{1}{\ln \frac{z}{z_0}}$$

Characteristic standard deviation values shall be used for the wind speed:

$$\sigma_{U,c} = I_{T,15} \frac{U_{10,15} + aU_{10}}{a + 1}$$

$$U_{10,15} = 15 \text{ m/s}$$

$I_{T,15}$ or I_{ref} (above mentioned) is the characteristic value of the turbulence intensity at 15 m/s and a is the slope parameter.

2.2.4 Turbulence Intensity

(see also IEC 61400-1, Table1)

The turbulence intensity I_T is defined as the ratio between the standard deviation σ_U of the wind speed and the 10-minute mean wind speed U_{10} .

The phenomenon of wind turbine influenced turbulence is known as a wake effect.

Wake effect shall be considered when turbines are installed behind other turbines with a distance of less than twenty times the rotor diameter.

Guidelines

The following method can be used to consider the wake effects.

The free flow turbulence intensity I_T is modified by the wake turbulence intensity $I_{T,w}$ to give the total turbulence intensity $I_{T,tot}$.

$$I_{T,tot} = \sqrt[m]{(1 - N \cdot p_w) I_T^m + p_w \sum_{i=1}^N I_{T,w}^m \cdot s_i}$$

$$p_w = 0,06$$

$$s_i = \frac{x_i}{D}$$

$$I_{T,w} = \sqrt{\frac{1}{(1,5 + 0,3 s_i \sqrt{v})^2} + I_T^2}$$

N Number of closest neighbouring wind turbines;
 m Wöhler (S-N fatigue) curve exponent corresponding to the material of the considered structural component (normally $m = 3$ for steel);

v Free flow mean wind speed at hub height;

p_w Probability of wake conditions;

x_i Distance to the i -th turbine;

D Rotor diameter;

$I_{T,w}$ Maximum turbulence intensity at hub height on the centre of the wake.

If the wind farm consists of more than five rows with more than five turbines in each row, or if the distance between the turbines in the rows that are located perpendicular to the predominant wind direction is less than three times the diameter, the increase in mean turbulence intensity is to be taken into account.

In this case the free flow turbulence I_T is substituted with I_T^* , where x_r is the distance within row and x_f is the distance between rows.

$$I_T^* = \frac{1}{2} \sqrt{I_w^2 + I_T^2} + I_T$$

$$I_w = \frac{0,36}{1 + 0,08 \sqrt{s_r s_f v}}$$

$$s_r = \frac{x_r}{D}$$

$$s_f = \frac{x_f}{D}$$

In addition to the turbulence in the direction of the mean wind (longitudinal), there will be turbulence also laterally and vertically.

2.2.5 Stochastic Turbulence Model

The spectral density of the wind speed process expresses how the energy of the wind turbulence is distributed between various frequencies. Spectral moments are useful for representation of the wind speed process $u(t)$.

Frequently used models that satisfy the norm requirements (ref. IEC 61400-1 Annex B) are the Mann uniform shear turbulence and the Kaimal spectrum and the exponential coherence model.

Guidelines

The following expression is reported for the Kaimal spectrum.

$$S_k(f) = \sigma_k^2 \frac{4 \frac{L_k}{U_{10}}}{\left(1 + 6 \frac{f L_k}{U_{10}}\right)^5}$$

S_k is the single-sided velocity components spectrum.
 σ_k is the velocity component integral scale parameter.
 k is the index referring to the velocity component direction (longitudinal, lateral, upward).
 λ is the turbulence scale parameter.

SECTION 4 – ENVIRONMENTAL CONDITIONS

The turbulence spectral parameters are given for each velocity component $k=1,2,3$.

	1	2	3
σ_k	σ_1	$0,8 \sigma_1$	$0,5 \sigma_1$
L_k	$8,1 \lambda$	$2,7 \lambda$	$0,66 \lambda$

At any point in time, there will be variability in the wind speed from one point to another. The closer together the two points are, the higher is the correlation between their respective wind speed. The wind speed will form a random field in space.

A commonly used model for the autocorrelation function of the wind speed field can be derived from the following exponential coherence model to account for the spatial correlation structure of the longitudinal velocity component.

$$\text{Coh}(r, f) = e^{-c \cdot f \cdot \frac{r}{u}}$$

Where r is the distance between the two points, u is the average wind speed over the distance r , f is the frequency and c is the non dimensional decay constant which reflects the correlation length of the wind speed field.

2.2.6 Extreme Wind conditions

The extreme wind conditions are normally referred (according to IEC 61400-1, subclause 6.3.2) to a 50-year return period.

The characterization of a 50-year wind speed requires an extreme value analysis of available wind speed data.

It has been proven useful to carry out such an extreme value analysis on the frictional velocity pressures derived from the wind speed data, rather than on the wind speed data themselves.

For this purpose, the observed wind speeds $u(z)$ are transformed to friction velocity u^* through the following inverse formula:

$$u^* = \frac{\kappa u(z)}{\ln\left(\frac{z}{z_0}\right)}$$

Von Karman’s constant $\kappa = 0,4$ and neutral atmospheric conditions are assumed.

Guidelines

The friction velocities u^* derived from the above transformation refer to the prevailing local roughness z_0 .

It is often desirable to transform the friction velocities to data related to a reference roughness $z_0 = 0.05 \text{ m}$, which is different from the true local roughness parameter.

This can be done by geostrophic mapping, thus utilising the fact that the geostrophic wind speed G is constant and equal for every roughness z_0 .

$$G = \frac{u^*}{\kappa} \sqrt{\left(\ln\left(\frac{u^*}{f z_0}\right) - A\right)^2 + B^2}$$

$A = 1,8$
 $B = 4,5$
 $f = 1,2 \cdot 10^{-4} \text{ rad/s}$

f is the Coriolis parameter and it is referred to a latitude of 55.5° .

The geostrophic wind speed G is calculated explicitly by the given formula when the true roughness z_0 and the corresponding u^* are given.

For this value of G , the same formula is used to implicitly solve a new value of u^* that corresponds to the desired new reference roughness z_0 .

When the friction velocities have been determined from the wind speed data as described above, the corresponding velocity pressure q is calculated.

$$q = \frac{1}{2} \rho (u^*)^2$$

The q data are grouped into n subrecords of a specified duration and the maximum value of q in each of the n subrecords is extracted. When the duration is one year, these n maximum values of q constitute an empirical distribution of the annual maximum velocity pressure. The velocity pressure q is expected to follow a Gumbel distribution.

$$F(q) = e^{-e^{-\frac{q-b}{a}}}$$

The parameters a and b are determined fitting to the n observations of the annual maximum velocity pressure: b is interpreted as the value of q which has recurrence period of one year.

The value of q that has a recurrence period of T years can be found using the following formula, where T_0 is 1 year.

$$q_T = b + a \ln \frac{T}{T_0}$$

The previous formula can be used to find the 50-year velocity pressure q_{50} .

The corresponding 10-minute mean wind speed $U_{10,T}$ with recurrence period T at height z and terrain roughness z_0 can be found.

$$U_{10,T} = \frac{1}{\kappa} \sqrt{\frac{2q_T}{\rho_0}} \ln \frac{z}{z_0}$$

When the wind speed with a 50-year recurrence period is given, i.e. $U_{10,50}$, the wind speed with recurrence period T years can be found.

$$U_{10,T} = U_{10,50} \sqrt{0,57 + 0,11 \ln \frac{T}{\ln \frac{1}{p}}}$$

SECTION 4 – ENVIRONMENTAL CONDITIONS

p is the probability of no exceedances in T years and n is the number of exceedances per year, given by $p = e^{-nT}$.

2.2.7 Wind shear

(see also IEC 61400-1, Subclause 6.3.2.6)

Wind shear is defined as the variation of the wind speed with the height: it is important for large and flexible rotors.

Guidelines

Wind shear profiles can be derived from logarithmic model modified by a stability-corrected logarithmic wind shear profile as follows.

$$u(z) = \frac{u^*}{\kappa} \left(\ln \frac{z}{z_0} - \psi \right)$$

$\psi > 0$ for unstable conditions

$\psi < 0$ for stable conditions

$\psi = 0$ for neutral conditions

The stability function ψ depends on the non-dimensional stability measure $\zeta = z/L_{MO}$, where z is the height and L_{MO} is the Monin- Obukhov length.

for $\zeta \geq 0$

$$\psi = -4.8$$

for $\zeta < 0$

$$\left\{ \begin{aligned} \psi &= 2 \ln(1 + x) + \ln(1 + x^2) - 2 \operatorname{tg}^{-1}(x) \\ x &= (1 - 19,3 \zeta)^{1/4} \end{aligned} \right.$$

The Monin- Obukhov length L_{MO} depends on the heat flux and on the frictional velocity u^* .

Its value reflects the relative influence of mechanical and thermal forcing on the turbulence as follows:

Atmospheric conditions	L_{MO} [m]
Strongly convective days	-10
Windy days with solar heating	-100
Windy days with little sunshine	-150
No vertical turbulence	0
Purely mechanical turbulence	∞
Nights where temperature stratification slightly dampens mechanical turbulence generation	> 0
Nights where temperature stratification severely suppresses mechanical turbulence generation	$\gg 0$

If data for Richardson number R are available, the following relationships can be used to obtain the Monin-Obukhov length L_{MO} .

$$L_{MO|unstable\ air} = \frac{z}{R}$$

$$L_{MO|stable\ air} = z \frac{1 - 5R}{R}$$

The Richardson number can be computed from averaged conditions as follows.

$$R = \frac{g}{T} \frac{(\gamma_d - \gamma)}{\left(\frac{\partial \bar{u}}{\partial z}\right)^2 + \left(\frac{\partial \bar{v}}{\partial z}\right)^2} \left(1 + \frac{0,07}{B}\right)$$

T Temperature

$\gamma = -\partial T/\partial z$ Lapse rate

$\gamma_d \cong 9,8 \frac{^\circ C}{km}$ Dry adiabatic lapse rate

g Gravity acceleration

$\partial \bar{u}/\partial z$ and $\partial \bar{v}/\partial z$ are the vertical gradients of the two horizontal average wind speed components \bar{u} and \bar{v} and z denotes the vertical height.

Finally, the Bowen ratio B of sensible to latent heat flux at the surface near the ground can be approximated:

$$B \approx \frac{c_p}{L_{MO}} \frac{(\bar{T}_2 - \bar{T}_1)}{(\bar{q}_2 - \bar{q}_1)}$$

c_p is the specific heat, \bar{T}_1 and \bar{T}_2 are the mean temperatures at two levels denoted 1 and 2, \bar{q}_1 and \bar{q}_2 are the average specific humidity at the same two levels and it is calculated as fraction of moisture by mass.

2.2.8 Wind direction

Transient wind conditions can occur when either the wind speed or the direction changes.

The following transient conditions are to be considered, if relevant, besides stationary wind conditions:

- Extreme of wind speed gradient, i.e. extreme of rise time of gust;
- Strong wind shear;
- Simultaneous change in wind direction and wind speed;
- Extreme changes in wind direction.

3 Waves characterization

3.1 General

Sea waves may be defined by means of design deterministic waves having appropriate shapes, heights and periods, when the deterministic analysis is used, or by means of power spectral density functions when the stochastic description of waves analysis is used; this latter analysis is generally recommended for the proper representation of the wave climate affecting the design of an offshore floating unit.

In both the above-mentioned cases, the parameters describing the design waves are to realistically represent the most unfavourable load conditions anticipated for the structure and are to be based upon reliable wave statistics relevant to the geographical areas considered for the various phases of the design life of the structure.

The evaluation of the probability distribution of the waves that the structure will meet during its life is to be carefully considered to take account of possible fatigue effects on structural members and mooring system.

SECTION 4 – ENVIRONMENTAL CONDITIONS

3.2 Deterministic description of waves

When the deterministic method of sea description is used, the design waves are defined by means of the following parameters:

- H : wave height, i.e. the distance measured vertically between the crest and the trough of the wave, in m;
- T : wave period, in s;
- L : wave length, in m;
- d : mean sea depth, in m.

Where necessary, the shallow water effects are to be taken into consideration.

According to IEC 61400-3, subclause 6.4, the marine conditions to be considered for the design of the an offshore wind structure are classified in:

- Normal marine conditions which will occur more frequently than once per year.
- Extreme marine conditions which are defined as having 1-year or 50-year recurrence period.

Therefore, in order to define the design extreme wave height, the smaller of the following heights is to be selected:

- the 50-yr wave height for the geographical areas concerned;
- the breaking wave height defined according to the wave periods and the water depth.

Guidelines

The diagram in Fig 1 is reported as general reference for definition of breaking wave height in relation to the two driving parameters.

For the description of the wave profile and wave particle kinematics the appropriate wave theory is to be used.

Guidelines

The diagram in Fig 2 is reported as general reference from API-RP2A Standard Practice for steel fixed offshore structures.

Figure 1: Breaking wave height

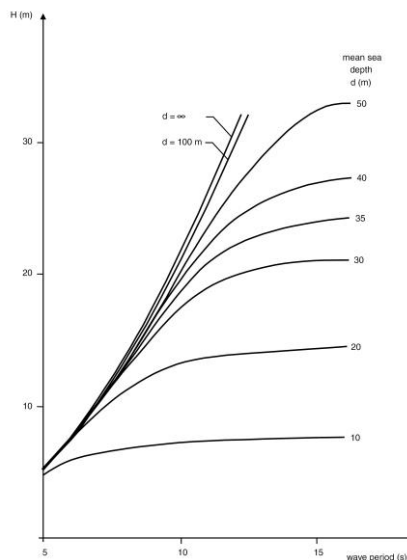
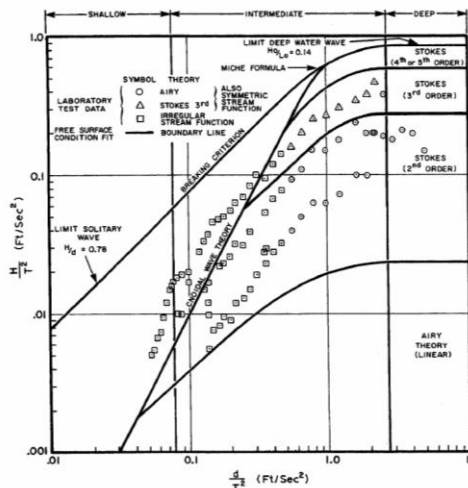

Figure 2: Ranges of validity for wave theories (from API-RP2A)



SECTION 4 – ENVIRONMENTAL CONDITIONS

3.3 Stochastic description of waves

When the stochastic method of sea description is used, the waves are analysed taking into account stationary irregular sea states described by the spectral power density function.

The analytical expressions of the spectral power density function of the sea states are to reflect the shape and the width of the spectra given for the geographical areas considered.

According to the dynamic analysis method, the long term sea behaviour is mathematically described by means of the occurrence probability of each short-term spectrum, i.e. by means of a distribution function of sea states.

Generally, the distribution function is used in bi-parametrical form (e.g. significant wave height H_s and peak period T_p), which may be obtained from wave statistics relevant to the geographical areas considered.

Wave energy directional distribution shall be considered using an appropriate spreading function.

A design sea state is described by:

- The wave spectrum S_η
- The significant wave height H_s
- The peak period T_p

The wave climate at a location can be considered stationary within periods of typically 3 hours.

3.3.1 Significant wave height

H_s is a measure of the intensity of the wave climate and is statistically defined as the average of the highest one-third of the wave heights recorded during a sea state.

Guidelines

In deep waters, the sea elevation process η is a Gaussian process and the individual wave height H follows a Rayleigh distribution where H_s is given and ν is the spectral width parameter.

$$F_H(h) = 1 - e^{-\frac{2h^2}{(1-\nu^2)H_s^2}}$$

The distribution of H_{max} can then be approximated using N that denotes the number of zero-up crossing of the sea elevation process in this period.

$$F_{H_{max}}(h) \approx e^{-N e^{-\frac{2h^2}{(1-\nu^2)H_s^2}}}$$

The expected value of the maximum wave height $E[H_{max}]$ can be expressed as follows.

$$E[H_{max}] \approx H_s \sqrt{\frac{(1-\nu^2) \ln N}{2}}$$

A first order approximation yields the following value for the spectral width parameter $\nu = 0,43$.

With this value of ν , the following relationship between the significant wave height H_s and the maximum wave height

$$H_{max} = 1.86 H_s$$

can be obtained.

However, a realistic value for the factor (1.86) introduced in this relationship shall be assumed in the design, where the 50-year maximum wave height is often estimated as a factor times the 50-years significant wave height.

Indeed, the use of 1.86 is reported as non-conservative in deep waters.

In offshore deep waters, i.e. the possible location for floating wind farms, the factor introduced may reach a value of about 2.0.

In shallow waters, the wave heights will be limited by the water depth d , due to breaking of waves.

The maximum possible wave height at a water depth d is approximately equal to $0.8d$.

3.3.2 Peak period

The peak period T_p is the period of the wave with the highest energy. The peak wave period is extracted from the spectra of the power density and it is correlated to the zero-up crossing period T_z .

Once the significant wave height H_s is given, the zero-up crossing period T_z is usually represented by a shifted lognormal distribution and it is defined as the mean time interval between upward or downward zero crossings on a wave record.

$$F_{T_z}(t) = \Phi\left(\frac{\ln(t - \delta) - a_1}{a_2}\right) \quad t \geq \delta$$

Φ denotes the Gaussian distribution function. a_1 and a_2 are function of H_s and the shift parameter δ can be approximated in seconds by $\delta \approx 2.2\sqrt{H_s}$.

Guidelines

The peak period T_p is related to the mean zero-crossing period T_z of the sea elevation process:

$$T_z = T_p \sqrt{\frac{5 + \gamma}{11 + \gamma}}$$

$$\gamma = \begin{cases} 5 & \text{for } \frac{T_p}{\sqrt{H_s}} < 3,6 \\ e^{(5,75 - 1,15 \frac{T_p}{\sqrt{H_s}})} & \text{for } \frac{T_p}{\sqrt{H_s}} = 3,6 \div 5,0 \\ 1 & \text{for } \frac{T_p}{\sqrt{H_s}} > 5 \end{cases}$$

3.3.3 Power spectral density

The analysis of the distribution of the wave energy as a function of wave frequency for a time-series of individual waves is referred to as a spectral analysis.

The frequency content of the sea elevation process characterized by an angular acceleration of ω can be represented by the power spectral density.

The most frequently used spectra for wind generated seas are the Pierson-Moskowitz spectrum for a fully

SECTION 4 – ENVIRONMENTAL CONDITIONS

developed sea, and the Jonswap spectrum for a developing sea.

The two spectra are related:

$$S_{JS}(f) = C(\gamma) \cdot S_{PM}(f)\gamma^\alpha$$

where γ is the peak-shape parameter and $C(\gamma)$ is the normalising factor.

The first factor increases the peak and narrows the spectrum; the second reduces the spectral density to ensure that both spectral forms have the same H_s . The formulation has been chosen so that $\gamma = 1$ recovers the Pierson-Moskowitz spectrum.

The Jonswap spectrum is formulated as follows:

$$S_\eta(\omega) = \frac{5}{32\pi} \cdot H_s^2 T_p \cdot \left(\frac{\omega T_p}{2\pi}\right)^{-5} \cdot e^{-\frac{5}{4}\left(\frac{\omega T_p}{2\pi}\right)^{-4}} \cdot C(\gamma) \cdot \gamma^{-\frac{1}{2\sigma^2}\left(\frac{\omega T_p}{2\pi}-1\right)^2}$$

$$C(\gamma) = 1 - 0,287 \ln \gamma$$

$$\sigma = \begin{cases} 0.07 & \text{for } \omega \leq \frac{2\pi}{T_p} \\ 0.09 & \text{for } \omega > \frac{2\pi}{T_p} \end{cases}$$

The JONSWAP wave spectrum normally recommended for representation of wind-generated waves may be inappropriate to some extent for floating wind turbine structures design, whose motion in heave, roll and pitch induced by swells of 20 to 25 seconds period may be significant.

For floating wind turbine structures that are designed for an environment which includes swells, a two-peaked spectrum (e.g. the Torsethaugen spectrum developed for the North Sea) is recommended for more appropriate representation of the power spectral density.

As an alternative, two JONSWAP spectra can be combined to represent wind-generated waves and swell, considering also, if possible, different directions.

4 Current characterization

4.1 General

Sea currents may vary in space and time, they are generally considered as a horizontally uniform flow field of constant velocity and direction, varying only as a function of depth.

The following components of sea current velocity are to be considered (ref. IEC 61400-3, Subclause 6.4.2.1-3):

- Sub-surface currents;
- Wind generated, near surface currents;
- Near shore, wave induced surf currents (ref. IEC 61400-3 Annex C).

The total current velocity is the vector sum of these components.

The designer shall determine whether sea currents may be neglected for calculation of fatigue loads by

means of an appropriate assessment of site-specific data.

Information on frequency of occurrence of total current speed and directions at different depths for each month and/or each season is useful for planning operations.

The characteristics of the current profile over depth depend on the regional oceanographic climate, in particular the vertical density distribution and the flow of water into or out of the sea.

The current model can be defined as normal NCM (Normal Current Model) or extreme ECM (ref. IEC 61400-3, Subclause 6.4.2.4-5).

4.2 Current data

The current velocity data (intensity, direction and variation depending on the distance above the sea bottom) relevant to the geographical areas considered are to be deduced from reliable statistics.

4.3 Current modelling

When reliable data relevant to current velocity variations versus the distance from the sea bottom are not available, the following formulation may be used:

$$v(z) = v_{tide}(z) + v_{wind}(z)$$

where:

$$v_{tide}(z) = v_{tide}(d) \cdot \left(\frac{z}{d}\right)^{1/7}$$

$$v_{wind}(z) = v_{wind}(d) \cdot \left(\frac{z}{d}\right)$$

in which:

$v_{tide}(z)$, $v_{wind}(z)$: tidal current velocity and wind generated current velocity at a distance z above the sea bottom, in m/s;

$v_{tide}(d)$, $v_{wind}(d)$: tidal current velocity and wind generated current velocity at the still water surface, in m/s;

z : distance from the sea bottom to the point where the current velocity is to be calculated, in m;

d : distance from the sea bottom to the still water surface, in m.

The current velocity of the wave fluid particles above the mean still water level is to be assumed equal to the velocity at the mean still water level.

Unless indicated otherwise the wind-generated current at still water level may be estimated as:

$$v_{wind}(d) = 0.01 \cdot U_{10}$$

where U_{10} is the 1-hour mean wind speed, in m/s, measured at a height of 10 m above the still water level.

In locations where the sea floor is subject to erosion, special studies on currents in proximity of the sea bottom may be required.

5 Water depth including tidal variations

The water depth at the final installation site of the floating structure shall be defined including variations due to tides and storm surge.

SECTION 4 – ENVIRONMENTAL CONDITIONS

For the definition of the different levels of water depth to be considered in both design and operability of offshore structures, general reference can be made to Fig. 1 of ISO 19901-1.

The different contributions to the offshore site water level definitions for the floating installation design are reported in the following Fig 3 (with ref., e.g., to a TLP-type floater).

The mean still water level to be used in wave load calculations is defined as the level which produces the

most unfavourable effects in the range between the highest astronomical tide level, increased by the wind and pressure induced effects, and the lowest astronomical tide level.

Figure 3: water level definitions

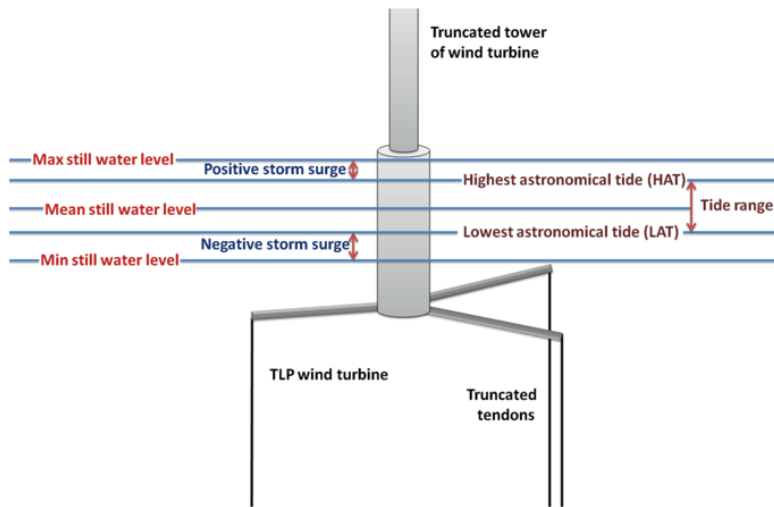

Data relevant to the tide components are to be supplied by recognised meteorological-oceanographic institutes.

In consideration of difficulty in the evaluation of tide components, where data directly applicable to the final location of the structure are not available, data extrapolated from those for nearby locations may be accepted.

Guidelines

Usually, by increasing the water level due to storm surge and tide, the hydrostatic loads and current loads on the structure increase. However, it is possible that lower water levels imply the larger hydrodynamic loads. Also, the air gap decreases for higher mean water levels.

With reference to the schematic layout of a TLP wind turbine shown in Fig. 4-3 with respect to different water levels, when increasing water level, the loads in tendons get higher, which is an issue to be considered for the strength assessment of the tender. When the water level decreases, the tension decreases, which, in combination to wave and relative motion of the floater, can cause slack in the tendons.

The contribution of variation of the water level causing fatigue to the tendons and local connections to the floater should also be considered, if significant.

6 Temperature

Extreme values of temperature are to be expressed in terms of the most probable highest and lowest values and their corresponding recurrence periods.

Both air and sea temperature are to be considered.

The design temperature for the various components of the platform is to be assumed equal to the lowest daily average air temperature or sea temperature, depending on the position of the single components, for the geographical areas concerned.

The lowest daily average temperature is defined as the lowest of the daily average temperature values continuously recorded over a sufficient number of years (at least 10), at a height of 10m above sea level for air temperature and 1m below sea level for sea temperature.

7 Sea ice, ice accretion and snow

(see also ISO 19901-1, Subclauses 10.4 and 10.5)

In the case of structures located in sea areas where ice may develop or drift ice may be present, this environmental condition is to be considered.

To properly characterize the ice environmental condition, particular consideration is to be given to the following issues:

- a) ice concentration and distribution;
- b) type of ice (ice floes, ice ridges, rafted ice, etc.);

SECTION 4 – ENVIRONMENTAL CONDITIONS

- c) mechanical properties of ice;
- d) ice drifting speed;
- e) ice thickness;
- f) probability of incoming icebergs.

The possibility of ice formation on the structure is to be duly considered with particular attention to ice concentration, distribution and thickness, particularly where icing increase the loads acting on the structure. When relevant, snow accumulation shall be taken into account in the design of the structure.

8 Marine fouling

(see also ISO 19901-1, Subclause 10.1)

Marine fouling on the submerged or wet part of the structure is to be duly evaluated if significant for specific design topics (e.g. weight definition or wave loading effect); the evaluation is to be done on the basis of biological and environmental factors, relevant to the water in the site considered, such as:

- a) salinity;
- b) oxygen content;
- c) pH value;
- d) current;
- e) temperature.

9 Earthquakes

The effects of earthquakes are to be considered when wind turbine structures are installed in seismically active geographical areas.

An area is defined as seismically active on the basis of its previous seismic history expressed in terms of frequency of occurrence and magnitude of earthquakes.

If an area is determined to be seismically active, earthquake loads are to be considered in the design, if relevant.

Assessment of seismicity can be of significant importance for design of TLP structures. The sensitivity to earthquakes is related to which modes of motion are restrained.

All types of floaters may be impacted either as a function of ground motions on the anchors or by associated sudden wave loading.

For the purpose of structural design, the seismic activity of an area may be expressed in terms of effective ground acceleration associated with a response spectrum or by means of a time history of the ground accelerations of the earthquake assumed for the design.

The most widely used input parameter for the seismic verification of offshore structures is the design response spectrum, i.e. the spectral response associated to given level of peak ground acceleration (PGA), which shall be obtained from a site-specific seismic hazard assessment.

The site-specific seismic hazard assessment will provide the response spectrum computed from a probabilistic seismic hazard analysis (PSHA) by taking into account local soil conditions.

In general, the site-specific seismic hazard assessment can be carried out according to the provisions of Clause 8 of ISO 19901-2, Seismic Design Procedures and Criteria.

The analysis of seismic characteristics of the location is to include an evaluation of:

- a) characteristics of the ground motions anticipated for the design life of the offshore structure;
- b) allowable seismic risk in relation to the design operation;
- c) ground instability due to liquefaction;
- d) instability of the sea floor;
- e) proximity to faults.

The input parameter characterization for seismic assessment is to be made for two levels of earthquake, defined according to ISO 19901-2, Subclause 6.1 as follows:

- Extreme Level Earthquake (ELE): The structure shall be designed such that an ELE event will cause little or no damage.
During an ELE event, shutdown of operations is tolerable and the structure should be inspected following to an ELE occurrence.

- Abnormal Level Earthquake (ALE): The structure shall be designed such that overall structural integrity is maintained.

Considerable damage can be reached during an ALE event but loss of life and/or major environmental damage is avoided.

Return periods for both ELE and ALE events can be assigned according to the exposure level (ref. Section 3, 1.2.2), and target annual failure probabilities given in ISO 19901-2, Subclause 6.4, possibly modified to meet more stringent regulation or regional requirements, if any.

In general, other geologically induced hazards other than earthquake-induced ground motions, such as liquefaction, slope instability, faults, tsunamis, mud volcanoes and shock waves are mentioned and briefly discussed in ISO 19901-2.

When significant, they must be considered during the design of the specific floating wind turbine installation and appropriately addressed by special studies.

In the case of floating structures installed in shallow waters, the possibility of seaquake occurrence is to be considered by evaluating the actual likelihood of tsunamis affecting the location of the structure, being the effects of tsunamis potentially critical for the stationkeeping system.

10 Other environmental conditions

Other environmental conditions such as:

- Humidity;
- Air density;
- Solar radiation;
- Lightning (ref. Sec 12),

are to be considered if relevant for specific design topics.

SECTION 4 – ENVIRONMENTAL CONDITIONS

11 Surrounding environment conditions

The risk of ship collisions is to be addressed. Impact velocities and ship traffic data should be included in relevant risk analysis, if relevant.

The presence of pipelines, disposed matter, wrecks and all other possible obstacles at the location is to be mapped.

SECTION 5 – LOADS AND LOADING CONDITIONS

1 Introduction

In floating wind turbine structures design, consideration is to be given to all loads which, during all the phases of the design life, may influence the scantlings (both of the unit as a whole and of its structural members), and the stationkeeping system design.

In particular the loads which the floating offshore wind turbine installation will have to withstand in both pre-service (i.e. during fabrication, load-out, transportation, offshore installation and commissioning/decommissioning (removal) phases) and in-service (i.e. operation, maintenance and repair phases) conditions are to be considered.

In the evaluation of loads, the increase in dimensions and mass of the structure due to phenomena relevant to the surrounding environment, such as marine fouling and ice accumulation, is to be considered.

Guidelines

The joint wave and wind loads should be considered for the design of the offshore floating structures accounting for wind loads and their companion wave, current and water level conditions.

Considering the size and type of the support structure and turbine, the relative magnitude of the wave loads can be the dominant effect on the floating structure. Hydrodynamic loads can be the main cause of extreme loads that should be investigated in coupled analysis.

2 Types of loads

2.1 General

Loads acting on the structures may be primarily grouped into the following six types:

- Permanent loads;
- Variable functional loads;
- Deformation loads;
- Environmental loads;
- Accidental loads;
- Loads due to construction, transportation and installation.

2.2 Permanent loads

These loads include the gravitational loads:

- weight of the structure;
- weight of machinery and systems in permanent position;
- weight of permanent solid and liquid ballast, if any;
- external hydrostatic pressure and buoyancy on the watertight underwater structures,

as well as pretension loads for the mooring system, which are to be treated as permanent loads. They are dependent on the type of floating support structure and can be grouped as:

- pretension of tendons, used for TLP type floater, are to be considered permanent load, by introducing relevant value, evaluated with respect to the most unfavourable water level, in the design;

- pretension of mooring lines, if any, independently of features relevant to their material, i.e. pretension of mooring line made by combination of chains and steel wires or fibre ropes (even if not dominated by weight and subject to creep along time) is to be introduced in the design as permanent load; it is anyway recommended to measure the actual mean tension in a mooring line as installed for the purpose of verification of the design assumption.

2.3 Variable functional loads

Functional loads include all the loads that occur during the operation and normal use of the floating unit and are loads that are variable (in terms of magnitude, position and direction). They include:

- Actuation loads;
- Payload on access external and internal decks, platforms and ladders;
- Any equipment operational loads;
- Berthing loads from supply vessels during normal service;
- Weight of variable solid and liquid ballast, if any.

The characteristic values of functional loads are to be assumed on the basis of the Designer's specifications. Typically, payload acting on an offshore structure is not to be assumed less than:

- personnel spaces, accommodation spaces, walkway areas: 4.5 kN/m²;
- working areas: 9.0 kN/m²;
- storage areas: 13.0 kN/m².

Maximum allowable values of functional loads and of the combination of such loads for any area or structural component of the floating installation are to be anyway specified in the Operating Manual.

Loads due to mooring of supply units are to be maintained below the design value by the use of operational procedures and/or devices aimed at avoiding accidental overloads.

2.4 Deformation loads

These loads are due to deformations imposed, as applicable, on the structures by:

- temperature;
- differential settlements of restraints;
- creep;
- shrinkage;
- prestress,

the latter three applicable for concrete components of the installation (if any).

2.5 Environmental loads

All the forces induced on the structure by the environmental conditions specified in Sec 4 are defined as environmental loads.

Wind generated loads on the rotor and on the tower shall be taken into account. Wind generated loads on the rotor and tower consist both in wind loads directly produced by the inflowing wind as well as indirect loads

SECTION 5 – LOADS AND LOADING CONDITIONS

that result from the wind-generated motions of the wind turbine and its operation.

In light of that, even if this Guide is not specifically covering the WT components design, aerodynamic loads generated by rotors are addressed in Sec 5, [5]. In order to design the structures, the statistical environmental conditions are to be split into two reference conditions:

- operating environmental conditions: the environmental conditions within which the normal design service is performed. The recurrence period of such limiting condition is to be specified by the Designer and recorded in the Operating Manual. The typical recurrence period generally assumed is 1 year;
- extreme environmental conditions: environmental conditions defined by the action on the floating support structure of extreme loads; in typical offshore structures design, the typical recurrence period assumed for extreme wave loading characterization is the 100-years value (i.e. the value with a probability of exceedance in the distribution of annual maximum of wave height of 0.01). In offshore wind farm standard practice, extreme wind load effect is characterized by the 50-years value (i.e. the value with a probability of exceedance in the distribution of annual maximum of wind velocity of 0.02, that is 98% quantile). Characteristic values of environmental loads or load effects, which are defined as the 98% quantile in the distribution of the annual maximum of the load or load effect, shall be estimated by their central estimates.

For construction, transportation, installation and removal phases the recurrence period is to be determined depending on the geographical area, the season and the influence of environmental factors on the safety of the operations.

Guidelines

In particular, the recurrence period of the environmental conditions to be assumed in the analysis of the on bottom stability, as applicable depending on foundations type, during installation is to be appropriately selected depending on the duration of the marine operation for final installation, the geographical area and the season considered. For instance, for fixed offshore structure such period is not to be less than 10 years.

In general, for short-term operations or phases, the characteristic values of loads are to be based on reliable meteorological forecasts.

The simultaneous occurrence of various environmental loads is to be carefully considered in the design of the structure.

In general, seismic loads need not be considered as acting simultaneously with other environmental loads.

2.6 Accidental loads

Loads whose intensity and recurrence period are difficult to be defined belong to the group of accidental loads.

Examples of such loads are:

- loads from unintended collision by service vessels;
- explosion and fire loads;
- loads due to dropped objects;
- unexpected pressure loads due to failure of active ballast system or unintended change in pressure difference;
- accidental flooding;
- loss of mooring line or tendon;
- loads due to the Abnormal Level earthquake (ALE) (see Sec 4, [9]).

The characteristic values of accidental loads are subject to approval.

Guidelines

As regards collision loads, in absence of more refined evaluation, the following formula may be used:

$$F = [2.5 \cdot H / (g \cdot T^2) + 0.05] \cdot P$$

where:

F : collision load, in kN;

H, T : maximum wave height and period for which the possibility of the collision is considered in m and in s respectively;

P : weight of the unit which collides against the structure, in kN;

g : gravity acceleration, in m/s².

2.7 Loads due to construction, transportation and installation

Such loads act on the structure as a whole or on its parts due to possible temporary operations, such as:

- lifting;
- movement and handling onshore or onto floating units;
- location on supports;
- assembly;
- transportation on barges;
- towing of floating structure;
- launching from barge;
- upending;
- mooring;
- positioning in the location;
- ballasting and submerging;
- anchoring and foundations installation;
- installation of the turbine, modular components, etc.
- cable laying, etc.

Construction and installation loads are to be determined taking account of static values of forces, pressures, dynamic amplification factors, effects of working tolerances and the influence of environmental conditions.

SECTION 5 – LOADS AND LOADING CONDITIONS

3 Determination of environmental loads

3.1 General

Environmental loads are to be determined, based on the environmental data discussed in Section 4 relevant to the target region, by using analytical methods and simulation models appropriate for the type, size and shape of the structure as well as its expected response characteristics.

Simulations for determination of environmental load effects involve combination of wind and waves, which will require conversion of significant wave heights and mean wind velocity from their respective reference period, typically different, to a common reference period equal to the selected simulation length. For instance, specific provisions for conversion for a simulation length of 1 hour are reported in IEC 61400-3, Sect. 7.4.6.

In order to appropriately capture effects associated with the natural frequencies of floating support structures, a sufficient length of the simulations carried out for the environmental loads response analysis of the floater shall be ensured, i.e. typical duration of 10 minutes should be increased up to a minimum of 3 hours.

Since wind cannot be considered stationary over time scales as long as 3 hours, an appropriate number of stationary wind analyses over shorter timespans can be carried out to eventually combine them in a proper way.

Model tests are recommended and should be employed to validate design assumptions and response analysis.

3.2 Wind Loads

3.2.1 General

The effect of wind on the above water parts of the structure induces pressures and forces that are to be evaluated considering both sustained and gust velocities of the wind.

Theories, coefficients and calculations used for the evaluations of pressures and forces induced by wind are to be deemed acceptable by RINA.

As an alternative to the above calculations, the results of consistent model tests carried out by recognised technological laboratories may be accepted.

For the static structural analysis of the support structure, wind loads calculated on the basis of the 1 minute sustained wind velocity are to be used in combination with maximum wave loads.

When wind loads due to 3 seconds gust wind velocity are higher than those due to sustained wind loads combined with wave loads, loads due to gust wind are to be considered.

When performing dynamic mooring analysis the wind shall be modelled according to the selected energy spectrum.

For slender cylindrical members, in addition to the static wind loads, cyclic wind loads due to vortex shedding are to be considered.

Dynamic effects of gust wind are to be considered, as well as possible increase of wind velocity due to wind flow through closely spaced members.

For the determination of wind turbine loads the following shall be considered:

- tower shadow and vortex shedding
- wake effects due to the presence of other turbines (wind farms);
- aeroelastic effects (interaction between motion of the turbine and wind field);
- influence of the control system of the wind turbine (blade pitching and yaw of the rotor);
- turbulence and gusts;
- damping.

3.2.2 Aerodynamic loads generated by the rotor

Aerodynamic loads can be static or dynamic and they are caused by the airflow and its interaction with the rotor, that is interaction with hub and blades components of the wind turbine.

Aerodynamic loads due to these effects are to be calculated using recognized methods and appropriate numerical simulations, and included in the design of the floating wind turbine installation if required for local components verification.

General features relevant to these aerodynamic loads' evaluation are reported in Sec 5, [5].

3.3 Wave Induced Loads

Wave induced loads are to be determined by means of recognised techniques taking account of sea depth and of the shape, dimensions, and type of the structure.

The analysis of the loads induced by waves on the structure is to be carried out in order to ensure a sufficiently accurate determination of the maximum loads through a sensitivity analysis on the wave periods.

Hydrodynamic coefficients used for the analytical determination of wave loads may be taken from available published data, model tests or calculated with recognised numerical tools. Values of these coefficients are, in any case, subject to approval by RINA.

When, in the case of structures of complex shape, the analytical determination does not ensure sufficient reliability, the results of appropriate model tests are to be used.

In the determination of wave loads the following components are to be considered:

- forces due to wave velocity potential, which consists of the incident potential, the diffraction potential and the radiation potential;
- wave drift forces;
- viscous damping and drag forces due to the effects of boundary layer and vortex shedding;
- slamming loads.

SECTION 5 – LOADS AND LOADING CONDITIONS

Wave induced loads on slender structural members with cross-sectional dimensions less than approximately 1/5 of the passing wave length may be predicted by Morison's equation.

Guidelines

According to Morison's equation, the horizontal force acting on a vertical element dz of the structure at level z is expressed as follows.

$$dF = dF_M + dF_D$$

$$dF = C_M \rho \pi \frac{D^2}{4} \ddot{x} dz + C_D \rho \frac{D}{2} |\dot{x}| \dot{x} dz$$

- C_M inertia coefficients (inertia force)
- C_D drag coefficients (drag force)
- D diameter of the cylinder
- ρ water density
- \dot{x} horizontal wave-induced velocity of water
- \ddot{x} horizontal wave-induced acceleration of water
- A_w wave amplitude

Wave loads are strongly dependent on the water depth and it is important to consider effects of local variations in the water depth.

In particular, the appropriate wave theory to be used for deriving the velocity \dot{x} and the acceleration \ddot{x} for the boundary conditions (H_s, T_p) of a given wave is determined in relation to the water depth.

When the first-order (or Airy) wave theory is applicable, the horizontal wave velocity and acceleration are calculated as follows.

$$\dot{x} = A_w \omega \frac{\cosh [k(z + d)]}{\sinh[kd]} \sin \omega t$$

$$\ddot{x} = A_w \omega^2 \frac{\cosh[k(z + d)]}{\sinh[kd]} \cos \omega t$$

$$\omega^2 = g k \tanh[kd]$$

- k wave number
- d water depth

The velocity and the acceleration in Morison's equation need to be taken as the resulting combined current and wave velocity \dot{x} and acceleration \ddot{x} .

The resulting horizontal force F on the cylinder can be found by integration of Morison's equation for value of x from $-d$ (seabed) to 0 .

$$F = F_M + F_D$$

$$F = \int_{-d}^0 C_M \rho \pi \frac{D^2}{4} \frac{H}{2} \omega^2 \cos \omega t \frac{\cosh h[k(z + d)]}{\sinh h[kd]} dz +$$

$$\int_{-d}^0 C_D \rho \frac{D H^2}{2} \frac{H}{4} \omega^2 \sin \omega t |\sin \omega t| \frac{\cos h^2[k(z + d)]}{\sin h^2[kd]} dz$$

As mentioned above, Morison's equation is valid when the dimension of the structure D is small relative to the wave length L , $D < 0,2 L$, and it is valid for nonbreaking waves, i.e. when $H/L < 0,14$.

The inertia force and the drag force can be expressed as follows.

$$F_M = A_M \cos \omega t$$

$$F_D = A_D \sin \omega t |\sin \omega t|$$

A_M amplitudes of inertia force

A_D amplitude of drag force

$$A = \frac{A_M}{A_D}$$

$$\frac{H}{D} = \pi \frac{C_M}{C_D} \frac{\sinh^2[kd]}{\left(\frac{\sinh[2kd]}{4} + \frac{kd}{2}\right) A}$$

By calculating H/D and d/L it is possible to establish whether the inertia force or the drag force is the dominating force.

When the dimension of the structure is large compared to the wavelength, typically when $D > 0,2 L$, Morison's equation is no longer valid, and the diffraction theory is to be applied.

Guidelines

For a cylinder installed in water of depth d and subjected to a wave of amplitude A , this theory gives the following maximum horizontal wave force $F_{x,max}$.

$$F_{x,max} = \frac{4\rho g A \sinh [k(d + A \sin \alpha)]}{k^2 \tanh[kd]} \xi$$

ξ and α are parameters tabulated in literature and A is the wave amplitude.

The vertical arm of the wave force $F_{x,max}$ measured from the sea floor h_F is calculated.

$$h_F = d \frac{kd \sinh[kd] - \cosh[kd] + 1}{kd \sinh[kd]}$$

For floating support structures consisting of both large and slender members, a combination of diffraction and Morison equation can be used to evaluate the hydrodynamic loading. Appropriate model tests results or full scale measurements may also be used as a valid alternative.

The simultaneous effects of inertia forces and drag forces are to be vectorially added taking account, when applicable, of possible changes in water particle

SECTION 5 – LOADS AND LOADING CONDITIONS

velocity and acceleration due to the presence of the structure.

When the cross-sectional dimensions of structural members are comparable with member spacing, the effects of hydrodynamic interaction are to be considered.

Wave loads are strongly dependent on the water depth and it is important to consider effects of local and tidal variations in the water depth.

Wave force evaluation shall take into account shallow water effects, which increase the current due to blockage effects, change the system natural frequency determination due to nonlinear behaviour of moorings and affect wave kinematics.

For installation sites where the ratio of water depth to wave length is less than 0.25, non linear effects of wave actions are to be considered, by, e.g., modifying linear diffraction theory to account for nonlinear effects or, alternatively, by performing model tests.

Wave slamming loads are to be considered for structural components that are possibly subject to wave slamming during transportation, installation and operation.

Impact loads from waves on the structures are to be determined according to recognised theoretical methods or from results of model tests. Possible dynamic amplification of such loads is to be carefully considered.

Breaking wave slamming loads are also to be considered if applicable.

The possibility of vortex induced cyclic loads is to be considered.

Green water effects are to be considered, as applicable, for the strength of topside deck structure and for the floating stability analysis.

Wave forces on mooring lines and/or tendons shall be calculated using the Morison's equation and appropriate hydrodynamic coefficients, depending on the type of mooring line.

3.4 Current induced loads

Current induced loads on structural members consist of drag forces to which the same considerations for wave loads apply.

When acting simultaneously, the combined effects of current and waves may be evaluated within the field of application of Morison's equation, by adding vectorially the current velocity to the water particle velocity due to waves.

The possibility of vortex induced vibrations and motions (VIV and VIM) on the structure and mooring lines is to be considered. Vortex induced cyclic loads shall also be taken into account in fatigue assessment.

3.5 Ice loads

Ice loads are to be determined on the basis of statistics relevant to the geographical areas considered.

Ice loads can include:

- static loads due to ice accumulation on superstructures;
- impact loads due to impact of ice dropping during thaw;
- forces acting on the structures subject to wind and wave actions due to increase of exposed areas caused by ice accumulation;
- loads due to impact of ice floes against the structures.

The impact loads due to ice floes are to be based on full scale measurements or on model tests or on recognised theoretical calculation methods taking account of the nature of ice and its mechanical properties, of the shape of structures which may be subject to ice impact and of the direction of ice movement.

3.6 Seismic loads

3.6.1 General

The effects of earthquakes are to be considered in the design of wind turbine structures located in seismically active geographical areas for the operation phase. Seismic loads may be required to be considered during the construction phase only in special cases.

In general, two different levels of earthquake are to be considered (see Sec 4, [9]):

- Extreme Level Earthquake (ELE);
- Abnormal Level Earthquake (ALE).

The structure is to have strength such that stresses induced by the ELE are kept within allowable limits and sufficient ductility to ensure absorption and dissipation capacity of energy connected to the ALE and to prevent its final collapse.

3.6.2 Design requirements

a) Ground motion

The characteristics of ground motions used as a basis for the seismic analysis of the structure are to adequately represent the expected actual conditions of the considered area in terms of intensity, frequency content and energy distribution. The effects of local soil conditions in amplifying or damping the ground motions and in altering the frequency content are to be considered.

Ground motions may be described in terms of both response spectrum and time histories:

- Response spectrum

Standard response spectra generally recognised as being valid for the geographical area considered may be used.

The ground motion normally consists of three components which are to be applied simultaneously, i.e. in the two horizontal directions and in the vertical direction.

When the response spectrum method is used, the spectrum is to be fully applied equally along both principal orthogonal horizontal axes of the

SECTION 5 – LOADS AND LOADING CONDITIONS

structure and multiplied by 0.5 in the vertical direction.

When deemed necessary appropriate higher percentages are to be used.

When response spectra specifically valid for the location concerned are not available, the response spectrum of accelerations shown in Figure 5-1 may be used.

Such spectrum is normalised to a reference horizontal acceleration and therefore it is necessary to multiply the values given in Figure 5-1 by the effective soil acceleration (expressed as multiples of gravity acceleration g), which depends on seismicity of the structure site considered.

The three curves in Figure 5-1 refer to three different soil types:

Curve A: rock - crystalline conglomerate or shale-like material having shear wave velocities in excess of 914 m/s;

Curve B: shallow strong alluvium - competent sands, silts and stiff clays having shear strengths in excess of 72 kN/m² limited to depths of less than 61 m and overlying rock-like materials;

Curve C: deep strong alluvium - competent sands, silts and stiff clays with thicknesses in excess of 61 m and overlying rock-like materials.

The response spectrum shown in Fig. 5-1 is relevant to a modal damping (combination of structural and hydrodynamic damping coefficients η equal to 5% of critical damping, generally used for jackets of fixed offshore structures.

If values of modal damping η other than 5% are used, the spectral acceleration given in Fig. 5-1 is to be multiplied by the following factor D:

$$D = - \frac{\log(\eta/100)}{\log(20)}$$

which is appropriate for values of damping between 2 and 10%.

Characteristic values of effective soil acceleration of the site concerned are subject to approval by RINA.

- Time history.

If the time history method of analysis is used, the time histories used in each of the three orthogonal directions mentioned under “ground motion” above are to be scaled as specified in “response spectrum” above and generated or modified so that their normalised response spectra reasonably match the spectrum shown in Figure 5-1 in the frequency and damping ranges of interest.

The phasing of each of the three time history components may be different.

The analysis is to consider at least three different sets of time histories to take account of the potential sensitivity of the structure response to variations in the input motion.

b) Structural model.

The geometric-inertial representation of the structure-soil-water system is to effectively model the distribution of stiffnesses, masses and dampings.

In particular, as far as masses are concerned, in addition to the mass of the structural members and associated equipment, the mass of the liquids contained in tanks and non-watertight tubular members located below the mean still water level is to be considered.

In general, a three dimensional model is to be used allowing account to be taken of torsional responses due to asymmetry in structure mass or stiffness distribution.

c) Response analysis.

When the response spectrum method is used, a number n of modes is to be considered such as to account for at least 90% of the total energy of all vibration modes of the system concerned.

At least 6 modes having the highest energy content are to be included among the above n modes.

Individual modal responses may be combined in the design response intended as the square root of the sum of the squares of the individual modal responses.

Other combinations of modal responses, more appropriate in the single instances, are to be specially considered.

When the time history method is used, the design response is to be calculated as the average of the maximum values for each of the time histories considered.

For ELE design checks, stresses due to earthquake induced loads are to be combined with those due to:

- gravity loads;
- hydrostatic pressure;
- hydrostatic buoyancy,

all increased by a load factor equal to 1.1, while the seismic action is to be increased by a load factor of 1.3.

For the ALE condition verification, all the factors can be set equal to 1.

When required by the seismic characteristics of the geographical location, the sea depth and the soil properties, the effects of seaquakes and large deformations and instability of the seabed are to be considered.

SECTION 5 – LOADS AND LOADING CONDITIONS

Figure 5-1: Seismic acceleration spectrum

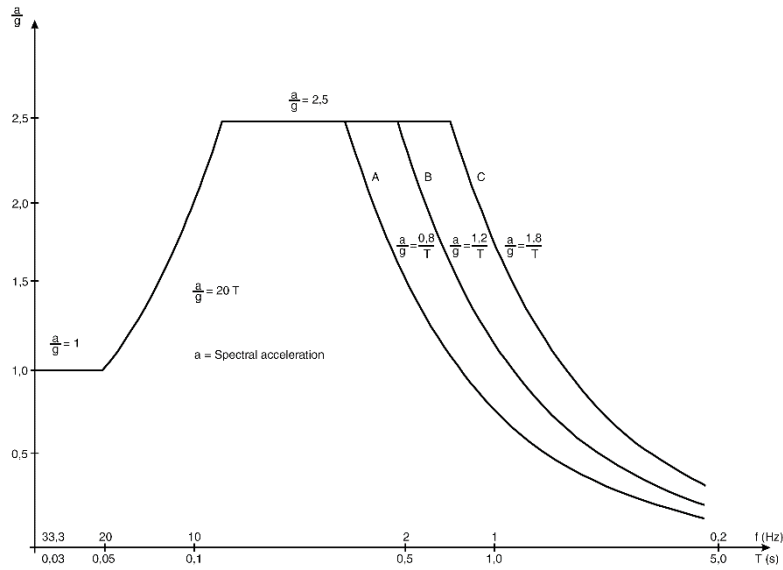

4 DETERMINATION OF LOADING CONDITIONS

4.1 General

The floating offshore wind turbine installation is to be analysed for the various loading conditions it will experience during its design life, in order to verify that relevant structures are able to withstand these loads with appropriate safety margin.

4.2 Design Load Cases

Load cases can be determined by combining the design situations relevant for the floating wind turbine installation with applicable external conditions.

Two classes of load cases are to be considered in the design, to represent the proper loading conditions:

- a) Design Load Cases (DLCs), properly defined to assess the floating offshore wind turbine unit under the combination of the site-specific environmental conditions with the possible wind turbine operational condition and the other applicable design conditions that may occur during pre-service and operation life;
- b) Survival load cases (SLCs) properly defined to verify the survivability of the stationkeeping system and adequacy of air gap during environmental conditions more severe than the design extreme environmental conditions.

4.2.1 Basic DLCs Requirements

For the determination of Design Load cases (DLCs) to be considered in the design of a floating wind turbine unit, basic reference can be made to Table 5-1.

The DLCs specified in Table 5-1 are adapted from Table 1 “Design load cases” of the standard IEC 61400-3, eventually modified to take into account the peculiarities of the floating support, therefore, for

acronyms and symbols reported in Table 5-1, besides the notes reported at the bottom of Table 5-1 itself, general reference can be made to Section 7.4 of the Standard IEC 61400-3, and, as applicable, to relevant considerations reported from Clause 7.4.1 to Clause 7.4.8 of the same Standard for the different design situations (specifically addressed by turbine condition, DLCs series from 1 to 8 respectively):

1. Power production;
2. Power production plus occurrence of fault or loss of electrical network connection;
3. Start up;
4. Normal shut down;
5. Emergency shut down;
6. Parked (standstill or idling);
7. Parked plus fault conditions;
8. Transport, assembly, maintenance and repair.

Thus, the following combinations are relevant for DLCs reported in Table 5.1:

- Normal operation and normal external conditions;
- Normal operation and extreme external conditions;
- Fault situations and appropriate external conditions;
- Transportation, installation and maintenance situations and appropriate external conditions.

Table 5-1 serves as a basis. It is the duty of the designer to apply it appropriately by taking into account possible factors, which can influence the involved wind conditions and the magnitude of the loads, depending on the specific wind turbine design, such as:

- Disturbance of the wind flow due to the presence of the tower;
- Wake effects wherever the wind turbine is to be located behind other turbines;
- Misalignment of wind flow with respect to the rotor axis;
- Changes necessitated by floating wind turbines development, in particular those reflecting that the

SECTION 5 – LOADS AND LOADING CONDITIONS

control system is used to keep the turbine in place by minimizing excitation.

Other design load cases may be considered to represent situations that are realistic and relevant for site specific design, for instance to account for correlation between an extreme environmental event and a fault condition of the wind turbine.

For floating offshore wind turbines that are to be installed in ice infested offshore sites, appropriate design load cases are to be considered for representing the effect of fast ice formation and moving ice.

In addition to basic DLCs defined in Table 5-1, the requirements reported in [4.2.4] are to be considered for the stationkeeping system design.

For each design situation, either ultimate strength analysis or fatigue strength analysis are to be carried out, as addressed in the second last column of Table 5-1, where the type of analysis is required for the limit states introduced in Sec 3, [2.1.1], while in the last column it is addressed the application of:

- the Partial Safety Factors (PSFs for loads and resistance) when ultimate strength analysis is to be carried out; the partial load safety factors are then provided differently for normal (N), abnormal (A), transport and erection (T) design situations: note that in this Guide the ultimate strength assessment associated to abnormal design situation has been characterized by ALS conditions. The specific values to be applied for the Partial Safety Factors are reported in [4.2.3];

or

- the Fatigue Design Factor (FDF) (see Sec 9, [2.5.7] c) for Floating Support Structures and Sec 10, [2.7.4] for Stationkeeping System) when the fatigue assessment is to be carried out-

Along with the application of Table 5.1, the notes reported in the bottom are to be considered.

SECTION 5 – LOADS AND LOADING CONDITIONS

Table 5.1- Design Load Cases

<i>Design situation</i>	<i>DLC</i>	<i>Wind condition</i>	<i>Waves</i>	<i>Wind & Wave direction</i>	<i>Sea current</i>	<i>Water level</i>	<i>Other conditions</i>	<i>Type of analysis</i>	<i>PSF</i>
Power production	1.2	NTM $V_{in} \leq V_{hub} \leq V_{out}$	NSS jpd of H_s, T_p, V_{hub}	MIS, MUL	NCM	NWLR or \geq MSL		FLS	FSF
	1.3	ETM $V_{in} \leq V_{hub} \leq V_{out}$	NSS $H_s = E[H_s V_{hub}]$	COD, UNI	NCM	MSL		ULS	N
	1.4	ECD $V_{hub} = V_r \pm 2$ m/sec	NSS $H_s = E[H_s V_{hub}]$	MIS, wind direction change	NCM	MSL		ULS	N
	1.5	EWS $V_{in} \leq V_{hub} \leq V_{out}$	NSS $H_s = E[H_s V_{hub}]$	COD, UNI	NCM	MSL		ULS	N
	1.6	NTM $V_{in} \leq V_{hub} \leq V_{out}$	SSS $H_s = H_{s,SSS}$	COD, UNI	NCM	NWLR		ULS	N
Power production plus occurrence of fault or loss of electrical network connection	2.1	NTM $V_{in} \leq V_{hub} \leq V_{out}$	NSS $H_s = E[H_s V_{hub}]$	COD, UNI	NCM	MSL	Control system fault or loss of electrical power	ULS	N
	2.2	NTM $V_{in} \leq V_{hub} \leq V_{out}$	NSS $H_s = E[H_s V_{hub}]$	COD, UNI	NCM	MSL	Protection system or preceding internal electrical fault	ALS	A
	2.3	EOG $V_{hub} = V_r \pm 2$ m/sec and V_{out}	NSS $H_s = E[H_s V_{hub}]$	COD, UNI	NCM	MSL	External or internal electrical fault including loss of electrical network	ALS	A
	2.4	NTM $V_{in} \leq V_{hub} \leq V_{out}$	NSS $H_s = E[H_s V_{hub}]$	COD, UNI	NCM	NWLR or \geq MSL	Control, protection or electrical system faults including loss of electrical network	FLS	FSF
	2.6	NTM $V_{in} \leq V_{hub} \leq V_{out}$	NSS $H_s = E[H_s V_{hub}]$	MIS, MUL	NCM	MSL	Transient condition between intact and redundancy check condition	ALS	A
	2.7	NTM $V_{in} \leq V_{hub} \leq V_{out}$	NSS $H_s = E[H_s V_{hub}]$	MIS, MUL	NCM	MSL	Stationary redundancy check condition	ALS	A
	2.8	NTM $V_{in} \leq V_{hub} \leq V_{out}$	NSS $H_s = E[H_s V_{hub}]$	MIS, MUL	NCM	MSL	Leakage (damage structure)	ALS	A
Start up	3.1	NWP $V_{in} \leq V_{hub} \leq V_{out}$	NSS $H_s = E[H_s V_{hub}]$	COD, UNI	NCM	NWLR or \geq MSL		FLS	F
	3.2	EOG $V_{hub} = V_r \pm 2$ m/sec and V_{out}	NSS $H_s = E[H_s V_{hub}]$	COD, UNI	NCM	MSL		ULS	N

SECTION 5 – LOADS AND LOADING CONDITIONS

	3.3	EDC $V_{hub} = V_r \pm 2 \text{ m/sec}$ and V_{out}	NSS $H_s = E[H_s V_{hub}]$	MIS, wind direction change	NCM	MSL		ULS	N
Normal shut down	4.1	NWP $V_{in} \leq V_{hub} \leq V_{out}$	NSS $H_s = E[H_s V_{hub}]$	COD, UNI	NCM	NWLR or \geq MSL		FLS	FDF
	4.2	EOG $V_{hub} = V_r \pm 2 \text{ m/sec}$ and V_{out}	NSS $H_s = E[H_s V_{hub}]$	COD, UNI	NCM	MSL		ULS	N
	4.3	NTM $V_{in} \leq V_{hub} \leq V_{out}$	SSS $H_s = \text{maximum operating limit}$	COD, UNI	NCM	NWLR	Sea state corresponding to the maximum operating limit	ULS	N
Emergency shutdown	5.1	NTM $V_{hub} = V_r \pm 2 \text{ m/sec}$ and V_{out}	NSS $H_s = E[H_s V_{hub}]$	COD, UNI	NCM	MSL		ULS	A
Parked (standstill or idling)	6.1	EWM $V_{hub} = k_1 V_{10min, 50-yr}$	ESS $H_s = k_2 H_{s, 50-yr}$	MIS, MUL	ECM 50-yr current	EWLR 50-yr water Level		ULS	N
	6.2	EWM $V_{hub} = k_1 V_{10min, 50-yr}$	ESS $H_s = k_2 H_{s, 50-yr}$	MIS, MUL	ECM 50-yr current	EWLR 50-yr water Level	Loss of electrical network	ULS	A
	6.3	EWM $V_{hub} = k_1 V_{10min, 1-yr}$	ESS $H_s = k_2 H_{s, 1-yr}$	MIS, MUL	ECM 1-yr current	NWLR	Extreme yaw misalignment	ULS	N
	6.4	NTM $V_{hub} \leq V_{10min, 1-yr}$	NSS jpd of H_s, T_p, V_{hub}	MIS, MUL	NCM	NWLR or \geq MSL		FLS	FDF
Parked plus fault conditions	7.1	EWM $V_{hub} = k_1 V_{10min, 1-yr}$	ESS $H_s = k_2 H_{s, 1-yr}$	MIS, MUL	ECM 1-yr current	NWLR		ALS	A
	7.2	NTM $V_{hub} \leq V_{10min, 1-yr}$	NSS jpd of H_s, T_p, V_{hub}	MIS, MUL	NCM	NWLR or \geq MSL		FLS	FDF
	7.3	EWM $V_{hub} = k_1 V_{10min, 1-yr}$	ESS $H_s = k_2 H_{s, 1-yr}$	MIS, MUL	ECM 1-yr current	EWLR 1-yr water Level	Transient condition between intact and redundancy check condition	ALS	A
	7.4	EWM $V_{hub} = k_1 V_{10min, 1-yr}$	ESS $H_s = k_2 H_{s, 1-yr}$	MIS, MUL	ECM 1-yr current	EWLR 1-yr water Level	Stationary redundancy check condition	ALS	A
	7.5	EWM $V_{hub} = k_1 V_{10min, 1-yr}$	ESS $H_s = k_2 H_{s, 1-yr}$	MIS, MUL	ECM 1-yr current	EWLR 1-yr water Level	Leakage (damage structure)	ALS	A
Transport, assembly, maintenance and repair	8.1	To be stated by manufacturer						ULS	T
	8.2	EWM $V_{hub} = k_1 V_{10min, 1-yr}$	ESS $H_s = k_2 H_{s, 1-yr}$	COD, UNI	ECM 1-yr current	NWLR		ALS	A
	8.3	NTM $V_{hub} \leq V_{10min, 1-yr}$	NSS jpd of H_s, T_p, V_{hub}	MIS, MUL	NCM	NWLR or \geq MSL	No grid during installation period	FLS	FDF

SECTION 5 – LOADS AND LOADING CONDITIONS

Notes to Table 5.1

- The DLC serial numbers has been adopted in line with IEC 61400-3;
- Similarly, the design environmental conditions referred in the Table for wind, wave, current and water level range are in accordance with metocean acronyms definitions adopted from IEC 61400-3, and listed below for prompt reference:

COD	Codirectional wind and wave direction
DLC	Design Load Case
ECD	Extreme Coherent gust with Direction change
ECM	Extreme Current Model
EDC	Extreme Direction Change
EOG	Extreme Operating Gust
ESS	Extreme Sea State
ETM	Extreme Turbulence Model
EWLR	Extreme Water Level Range
EWM	Extreme Wind speed Model
EWS	Extreme Wind Shear
FDF	Fatigue Design Factor
FLS	Fatigue Limit State check condition
MIS	Misaligned wind and wave direction
MSL	Mean Sea Level
MUL	Multi-directional wind and wave
NCM	Normal Current Model
NSS	Normal Sea state
NTM	Normal Turbulence Model
NWLR	Normal Water Level Range
NWP	Normal Wind Profile model
PSF	Partial Safety Factor

SSS	Severe Sea State
ULS	Ultimate Limit State check condition
UNI	Uni-directional wind and wave direction
N	Normal condition
A	Abnormal condition
T	Temporary condition
jpd	Joint Probability Distribution
H_s	significant wave height
$H_{s,1-yr}$	significant wave height with 1-year return period
$H_{s,SSS}$	significant wave height of the severe sea state
T_p	peak period of the sea waves spectrum
$H_s = E[H_s v_{hub}]$	expected significant wave height given a value of v_{hub}
v_{hub}	10-minute mean wind speed at hub height
$v_{10min,1-yr}$	10-minute mean wind speed at hub height with 1-yr return period
$v_{10min,50-yr}$	10-minute mean wind speed at hub height with 50-yrs return period
v_{in}	cut-in wind speed
v_{out}	cut-out wind speed
v_r	rated wind speed
$v_r \pm 2 \text{ m/sec}$	sensitivity to the wind speed in the range of speed ($\pm 2 \text{ m/sec}$) to be analysed
k_1	simulation time scaling factor for 10-minutes mean wind speed
k_2	simulation time scaling factor for significant wave height

SECTION 5 – LOADS AND LOADING CONDITIONS

- For the determination of the design environmental conditions reported in the Table 5.1, reference shall be made to what recommended in Sect 4 of this Guide;
- The DLCs considered in Table 5.1 are the ones applicable for the design of the floating support structure and its stationkeeping system, therefore DLC 1.1 reported by IEC 61400-3 for the extrapolation of the extreme loads on the Rotor Nacelle Assembly of the wind turbine has not been reported;
- For the (ULS) Ultimate Limit State analysis, the most unfavorable directions of the wind and the waves are to be assumed;
- The effect of current has been introduced as a requirement for (FLS) Fatigue Limit State assessment (e.g. requirement of NCN for DLC 2.4 or DLC 4.1);
- Additional design load cases 2.6 and 7.3 are relevant to the transient condition between intact and damaged stationkeeping system, while additional design load cases 2.7 and 7.4 refer to the stationary situation after the loss of one mooring component of the stationkeeping system;
- Additional design load cases 2.8 and 7.5 are relevant to the situation where the structure is damaged;
- Additional design load case 4.3 refers to a situation where the safety limits of the control system are triggered, that is the normal shutdown procedure when the sea state exceeds the maximum operational limit as defined in the Operating Manual. Upon requirements of the Operating manual, the emergency shutdown may need to be considered instead of the normal shutdown;
- As regards to DLCs 6.1 to 6.4, DLCs 7.1 to 7.2 and DLCs 8.2 to 8.3, differently from what indicated by IEC 61400-3, where these DLCs are related to RNA's reference wind speed, in Table 5.1 site specific extreme value of the wind speeds with various return periods have been introduced for the environmental conditions definition.
- As discussed in Sec 8, [1], the simulation time duration may differ from the reference period of the wind speed and that of the significant wave height; therefore, for those DLCs, as, e.g., DLC 6.1 or DLC 7.1, which require time domain dynamic analysis, two scaling factors, k_1 and k_2 , have been introduced in order to implement the methodology recommended in [2.2.3] of Section 8.
- Where a wind speed range is reported in Table 5.1, wind speed leading to the most unfavourable response is to be considered;
- For the ULS condition analysis the effect of the environmental loading conditions prescribed for relevant DLCs in table 5.1 is to be combined with the effect of permanent and variable loads, as applicable, to evaluate the most severe local and global effects on the floating support structure and/on the stationkeeping system;
- The return period for design environmental conditions to be used for DLCs 8.1 to 8.3 is to be in compliance with the provisions indicated in [2.5] (return period for temporary phases), if not otherwise specified by an installation operational plan that shall be ensured, at Owner responsibility, to be in compliance with the environmental conditions used in the design;
- As mentioned in [3.6.1], the seismic assessment, if applicable, is relevant to specific DLCs, which are to be analyzed in the design of the floating support structure and stationkeeping system, independently of consideration of extreme environmental condition

SECTION 5 – LOADS AND LOADING CONDITIONS

4.2.2 Verification requirements for floating support structure and stationkeeping system

For each DLC indicated in table 5.1 the type of analysis is reported as ULS or FLS.

ULS is the ultimate load strength analysis to be used in structural assessment against acceptance criteria pertaining to the yielding and buckling of the floating support structure component.

The DLCs indicated with ULS are further classified as N representing normal design conditions, which are expected to occur frequently during the design life of the floating wind turbine unit. The corresponding operational mode of the turbine is in a normal state of function or with minor faults.

A representing abnormal design conditions, which are less likely to occur than normal design conditions. They typically correspond to design conditions with severe faults that result in activation of system protection measures.

T representing the design condition relevant to the temporary phases, including load-out, transportation, installation and in-service maintenance of the floating wind turbine structure

Depending on the type of support structure – i.e. barge, spar, TLP, etc. – different checks are to be carried out. Specific provisions are reported in Sec 9, [4].

FLS denotes the fatigue analysis to be carried out in the structural assessment for the verification of fatigue performance, along the service life, of fatigue-sensitive components of the floating support structure or its stationkeeping system.

Relevant provisions are reported in Sec 9, [2.5] and Sec 10, [2.7] for fatigue assessment of floaters and stationkeeping system respectively.

4.2.3 Partial Safety Factors applicable for DLCs

a) Partial Load factors for strength checks (ULS and ALS)

In general, the effect of the prescribed environmental load is to be combined with the effect of permanent and variable loads producing the most unfavorable effect on the item subject of verification. For each design case reported in Table 5-1, the assessment of the load effect in any component of the wind turbine floating installation subject to the corresponding environmental loads combination is to be carried out according to the LRFD method (see Section 3), where the combined load effect of simultaneously applied load process is evaluated by the application of different partial load factors, typically assigned for the different categories of loads (see [2]):

- Permanent (gravity) loads
- Variable functional loads
- Environmental loads
- Deformation loads
- Prestressing loads

According to the same table, for each design situation, a partial safety factor (PSF) is to be associated among normal (N), abnormal (A), transport and erection (T) design situation.

In general, the partial safety factor is introduced, and calibrated accordingly (see also Section 3, [A3]) to account for:

- the variability in loads (ref. IEC 61400, Subclause 7.6.2.1) and materials (ref. IEC 61400, Subclause 7.6.2.2-3) characterization;
- the uncertainties in the analysis methods;
- the importance of structural components with respect to the consequences of failure (i.e. their exposure category, see Section 3, [1.2 and. IEC 61400-3, Subclause 7.6).

Provided that the partial safety factors for loads and materials to be used for the ultimate strength analysis of the RNA (not specifically covered by this Guide) of an offshore wind turbine shall meet the requirements of IEC 61400-3, Subclauses 7.6.1 and 7.6.2, for the partial safety factor to be used for the ultimate strength analysis in normal (N), abnormal (A), transport and erection (T) design situations of an offshore wind turbine installation, general reference can be done to IEC 61400-3, Subclauses 7.6.2, while specific safety factors for the fatigue check are provided in IEC 61400-3, Subclauses 7.6.3.

In the different design checks ULS is to be considered to reflect the ultimate limit state corresponding to maximum load resistance (or ultimate strength capacity) corresponding, e.g. to:

- loss of structural resistance due to yielding or buckling of steel material;
- loss of structural capacity due to brittle fracture;
- loss of global stability of the structure, or part thereof, as a rigid body, due to overturning or capsizing;
- loss of capacity due to the effect of cyclic loads;
- loss of capacity due to excessive deformation, which can occur in both (N) and (T) design situations.

Accidental limit State (ALS) conditions are to be verified for (A) design situations, corresponding to a damaged condition or in the presence of abnormal environmental conditions.

For the combination of the DLCs introduced in table 5-1 for the design of floating wind turbine installation, the Partial Load Safety Factors reported in Table 5-2 are to be applied, for the different categories of load,, for the different design situations and limit states considered in Table 5-1.

The table provides five sets of load factors to be used when characteristic loads or load effects from different load categories are combined to form the design load or the design load effect for use in design. The load factors apply to the in service phase as well as to the temporary phases: for these latter the set T is generally the applicable one for

SECTION 5 – LOADS AND LOADING CONDITIONS

marine operations, with due consideration made to the relevance of the environmental load.

For analysis of ULS in N design situations, relevant sets reported in the Table 5-2 are to be used when the characteristic environmental load is established with reference to 50-yr return period.

The load factors reported in Table 5-2 are generally applicable for all types of floating support structures and their stationkeeping system.

The environmental load factors depend on the exposure categories assigned for the structural

component under assessment. For some components of the stationkeeping system other safety factors requirements may apply as specifically recommended for their checks from design codes that may be actually used for design, where the WSD format is adopted. In particular for design of components and anchor foundation for mooring lines. Specific safety factor requirements are given in Section 10 and overrule the load factors of Table 5-2.

Table 5.2- Load Partial Safety Factors to be applied for Design Load Cases of Table 5-1

Design situation	Limit state	Load type					
		Permanent G	Variable Q	Environmental E for L3 exposure (1)	Environmental E for L2 exposure (1)	Deformation D	Prestressing (2)
N (3)	ULS	1.25	1.25	0.7	0.7	1.0	0.9/1.1
N (4)	ULS	1.25	1.25	1.0	1.0	1.0	0.9/1.1
N (5)	ULS	1.0 (6)	1.0	1.35	1.55	1.0	0.9/1.1
A	ALS	1.0	1.0	1.0	1.15	1.0	0.9/1.1
T	ULS	1.0	1.0	1.5	1.5	1.0	0.9/1.1

Notes to Table 5.2

(1) For exposure categories see [1.2.2] of Section 3. For prompt reference, it is reminded that for floating offshore wind turbine installations, if they are unmanned during severe environmental conditions and the structural failure is unlikely to lead to unacceptable consequences for the environment, an exposure level L3 may be the reference for the design of both the floating support structure and the stationkeeping system, provided that this latter is a redundant system. For stationkeeping systems without redundancy, in the design of their components the exposure level L2 is to be used.

(2) In addition to the factors for the load categories already introduced, when a prestressing load P is to be considered in the design situation, a PSF of 0.9 or 1.1 is to be applied as the most unfavourable for the design condition under verification.

(3) Set of partial load factors to be applied for Normal design situations of structures where permanent load or variable load is dominating.

(4) Set of partial load factors to be applied for Normal design situations of structures where permanent load or variable load is dominating and variable functional load is correlated to environmental loads (e.g. Q from both impact).

(5) Set of partial load factors to be applied for Normal design situations of structures where environmental load is dominating.

(6) It is assumed that tight weight control of the structure is performed for floating structures. If sensitivity studies show excessive dynamic excitations, the load factor for permanent load shall be varied between 0.9 and 1.1.

b) Partial Resistance Factors for strength checks (ULS and ALS)

A resistance factor g_R is to be introduced in the LRFD format here adopted for design checks to particularly account for:

Possible unconservative deviations in the resistance of material;

Model uncertainties in the formulations used for determining the structural resistance,

Therefore, the value of g_R is dependent on the specific limit state formulation of the check equation under consideration; relevant recommendations are reported for ULS design checks in relevant sections for design of floating support structure and anchoring system.

Resistance factors g_R introduced in the strength equation checks for ALS conditions are to be set equal to 1.0.

c) Partial Safety factors for fatigue checks (FLS)

Load factors g_i for FLS checks are to be set equal to 1.0 for all load categories, while it has to be introduced in relevant checks a DFF, to be applied to the calculated characteristic damage.

Relevant values of DFFs are reported in Sec 9, [2.5.8] for floating support structure, and Sec 10 [2.7.4] for stationkeeping system.

The environmental load factors depend on the exposure categories assigned for the structural component under assessment. For some components of the stationkeeping system other safety factors requirements may apply as specifically recommended for their checks from

SECTION 5 – LOADS AND LOADING CONDITIONS

design codes that may be actually used for design, where the WSD format is adopted. in particular for design of components and anchor foundation for mooring lines. Specific safety factor requirements are given in Section 10 and overrule the load factors of Table 5-2.

4.2.4 Additional DLCs for stationkeeping system

The DLCs reported in Table 5.1 are also provided for the design of the stationkeeping system, as applicable, but additional load cases should be considered, whenever relevant to the integrity of that system. In particular additional DLCs are to be considered depending on the possible effects on the mooring system of:

- the global yawing moment on the floating support structure that may arise following to unbalanced rotor aerodynamic loads caused by the shade or wake effect of neighbouring floating offshore wind turbines;
- the vortex induced motion of the submerged floating structure, as well as the VIV (vortex induced vibration) fatigue effects, generated by the site specific current conditions;
- significant motion on the foundation system of the mooring line, or tendon, induced by earthquake or fault displacement.

4.3 Survival Load Cases

Survival metocean conditions should be established for the design of wind turbine offshore installation in

regions where strong winter storms or tropical cyclones (hurricanes or typhoons) are not rarely to occur. The probability of joint occurrence of environmental parameters is to be taken into account for establishing survival metocean condition, which are to be introduced in Survival Load Cases (SLCs).

SLCs are to be eventually used for further strength assessment of the stationkeeping system and the evaluation of green water effects on the floater and relevant equipment.

In particular the maximum return period (n years) of the storm wind condition (and corresponding sea state, sea current and water level) that the turbine blades can withstand without damages is to be defined in order to carry out the assessment for the two design conditions reported in the following Table 5-3: for both design condition the hull of the floater is to maintain its structural integrity.

The effect of the prescribed environmental load is to be combined with the effect of permanent and variable loads producing the most unfavourable effect on the items subject of verification (i.e. stationkeeping system or air gap), with the safety factors applicable for SLCs reported in Table 5-4.

Additionally, for TLP type support structures, both the minimum tendon tension assessment (ref. slack check) and the possible 'one-tendon removed' design condition are to be carried out for the SLCs reported in Table 5-3.

Table 5-3 - Survival Load cases

<i>Design situation</i>	<i>SLC</i>	<i>Wind condition</i>	<i>Waves</i>	<i>Wind & Wave direction</i>	<i>Sea current</i>	<i>Water level</i>
Parked RNA, Intact blades	S.1	SUWM $V_{hub} = k_1 V_{10min, n-yr}$	SUSS $H_s = k_2 H_{s, n-yr}$	MIS, MUL	SUCM n-yr current	SUWLR n-yr water level
Parked RNA, One or more damaged blade(s)	S.2	SUWM $V_{hub} = k_1 V_{10min, 500-yr}$	SUSS $H_s = k_2 H_{s, 500-yr}$	MIS, MUL	SUCM 500-yr current	SUWLR 500-yr water level

Symbols in Table 5.3

SUWM	Survival Wind Model
SUSS	Survival Sea State
MIS	Misaligned wind and wave direction
MUL	Multi-directional wind and wave
MIS	Misaligned wind and wave direction
SUCM	Survival Current Model
SUWLR	Survival water Level Range
H_s	significant wave height

$H_{s, n-yr}$	significant wave height with a return period of n years
$H_{s, 500-yr}$	significant wave height with a return period of 500 years
V_{hub}	10-minute mean wind speed at hub height
$V_{10min, n-yr}$	10-minute mean wind speed at hub height with n-yr return period
$V_{10min, 500-yr}$	10-minute mean wind speed at hub height with 500-yr return period
n-yr	Maximum return period (in years) of the wind condition that the turbine blades can withstand by remaining intact, or 500 years, whichever is less
k_1	simulation time scaling factor for 10-minutes mean wind speed
k_2	simulation time scaling factor for significant wave height

SECTION 5 – LOADS AND LOADING CONDITIONS

Table 5.4- Load Partial Safety Factors to be applied for Survival Load Cases of Table 5-3

Design situation	Load type					
	Permanent G	Variable Q	Environmental E for L3 exposure [see note (1) Table 5-2]	Environmental E for L2 exposure [see note (1) Table 5-2]	Deformation D	Prestressing [see note (2) table 5-2]
S.1 and S.2	1.1	1.1	1.1	1.25	1.0	0.9/1.1

5 APPENDIX A5 – AERODYNAMIC LOADS GENERATED BY ROTORS

5.1 General

The aerodynamic load is determined as function of the average wind speed and turbulence across the rotor plane, the rotational speed of the rotor, the air density and the aerodynamic shapes of the wind turbine, including the aeroelastic effects. The wind velocity conditions at a blade cross section are illustrated in Figure 5.1.

Figure A5.1: “Wind velocity at a blade cross section”

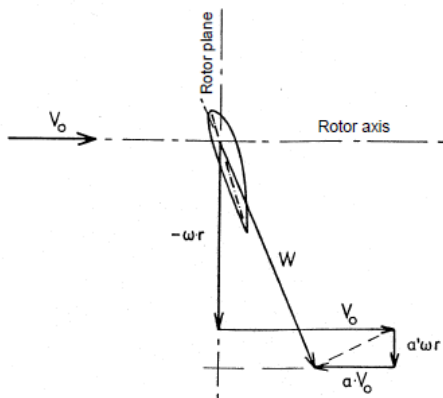

V_0 is the wind velocity perpendicular to the rotor plane. When the wind passes through the rotor plane, this wind speed becomes reduced by an amount of aV_0 due to the axial interference. Thus, a blade element at a distance r from the rotor axis will be moving at a speed ωr in the rotor plane. When the wind passes through the rotor plane and interacts with the moving rotor, a tangential slipstream wind velocity $a'\omega r$ is introduced. The resulting relative inflow wind velocity that the rotor blade will experience comes out and is denoted W . This resulting relative wind velocity gives rise to aerodynamic forces on the blade, respectively lift and drag force, F_L and F_D .

5.2 Aeroelastic loads calculation

The purpose of an aeroelastic analysis is to solve the equations of motion for a given arbitrary set of forces acting on the structure and for forces generated by the structure itself. The general formulation of the differential equations of motion contains the vector x and its derivatives, the mass matrix M , the damping matrix C , the stiffness matrix K and the force vector F acting on the structure varying with time.

$$M\ddot{x} + C\dot{x} + Kx = F$$

The necessary model elements for the aeroelastic load calculation are:

1. Wind field modelling
2. Aerodynamic model
3. Blade element momentum method
4. Beam theory
5. Control system modelling

5.2.1 Wind field modelling

The wind field contains the longitudinal, transversal and vertical wind velocity components and it is divided into a mean wind field and a fluctuating wind field. For wind turbines, spatial variations in the turbulence must be considered, and three-dimensional wind simulation is required. The first purpose is to predict time series of the wind speed in a number of points in space across the rotor disc of a wind turbine. In order to predict the wind field in a number of points in space, the spatial coherence of the wind field must be properly accounted for. There are two models available for generating a synthetic wind field over a rotor disc. Veers model by Sandia It uses a circular grid in the rotor plane and it is based on a single point spectral representation of the turbulence and a coherence function. A Kaimal formulation is chosen as the spectral model and an exponential Davenport coherence model is used.

SECTION 5 – LOADS AND LOADING CONDITIONS

$$S_i(f) = \sigma_i^2 \frac{6,8 \frac{L_i}{U}}{\left(1 + 10,2 \frac{fL_i}{U}\right)^{\frac{5}{3}}}$$

$$\text{coh}_i(r, f) = e^{-c_i r \frac{f}{U}}$$

i: velocity components (u, v, w)
 f: frequency
 r: distance or spatial separation
 L: integral length scale of the turbulence component
 σ: standard deviation of wind speed component
 c: coherence decay factor

- Mann model by Risø

It applies a quadratic grid and it is based on a spectral tensor formulation of the atmospheric surface layer turbulence.

The model has been developed with reference to onshore wind turbines and specifically for homogeneous terrain and the parameters used are: mean wind speed U, height above terrain z and roughness length z₀. Relevant considerations for offshore site are to be applied.

The turbulence intensity I_T, defined from the standard deviation of the longitudinal wind velocity σ_u, is usually measured by means of an anemometer.

$$I_T = \frac{\sigma_u}{U}$$

This measurement corresponds to vectorial summation of the longitudinal and transversal wind velocity components.

5.2.2 Aerodynamic model

Aerodynamic theory performs quantitative predictions of the forces set up by the airflow on the rotor.

The overall 3D-flow on a rotor is a very complex, unsteady flow depending on many variables such as wind speed, wind shear, atmospheric turbulence, yaw angle, rotational speed, rotor radius, overall layout of the rotor blade and the airflow properties.

For calculation of aerodynamic forces on a rotor blade, it is used the so-called “blade element momentum”.

The resultant force F is decomposed into two components F_L perpendicular to the direction of the resulting relative wind velocity W and F_D parallel to this direction.

Figure A5.2: “Wind resulting force”

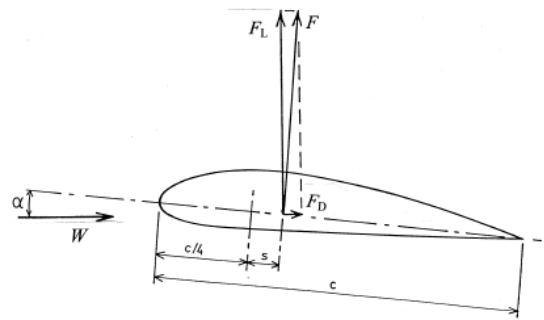

$$F_L = \frac{1}{2} C_L \rho c W^2$$

$$F_D = \frac{1}{2} C_D \rho c W^2$$

The aerodynamic drag force F_D on the tower and the nacelle can be calculated based on the projected area A perpendicular to the flow as follows:

$$F_D = 0,5 \rho A V_0^2 C_D$$

The lift and drag coefficients C_L and C_D are defined using the chord length c of the airfoil.

The lift and drag forces are functions of the:

- Inflow angle α (between the wind direction and the blade axis);
- Airfoil shape;
- Reynolds number Re = cW/ν, in which ν is the kinematic viscosity.

To describe the physics in a mathematical way, the wind turbine rotor can be considered as a disc, which is able to absorb energy from the wind by reduction of the wind speed as shown below.

Figure A5.3: “Wind speed reduction”

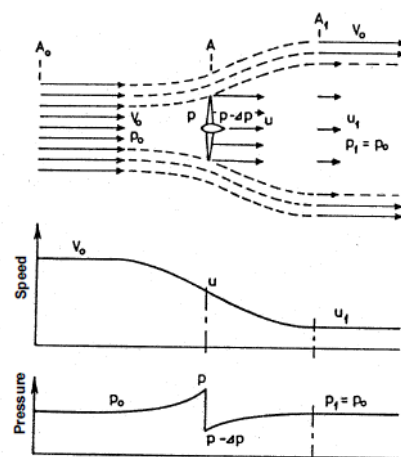

C_L increases linearly with α up to α_{stall} after which the profile stalls.

For greater value of α, C_L reaches a maximum value followed by a decrease for further increases in α.

α_{stall} characterizes the stall phenomenon, a nonlinear phenomenon that results in a dramatic loss of flow

SECTION 5 – LOADS AND LOADING CONDITIONS

attachment and airflow lift when a limiting inflow angle has been reached.

Two-dimensional wind tunnel calculations are used to obtain the coefficient values in the pre-stall region.

- Computational Fluid Dynamics (CFD)
- 2D wind field model
- Measurements and estimations

Figure A5.4: “Lift and drag curves”

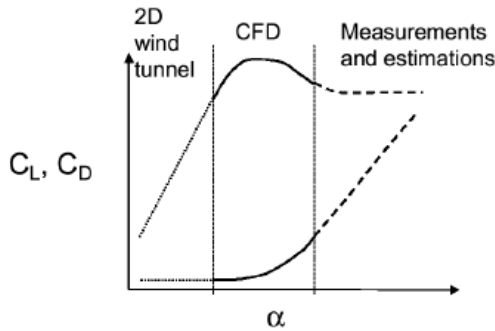

Note that proper selection of values for the aerodynamic coefficients is a very important step in the design analyses of a wind turbine.

The norm IEC 61400-3 requires that the load model used to predict loads for design verification of wind turbines be validated for each design load case.

This validation of the load prediction is to be based on a representative comparison between measured and predicted loads on a similar wind turbine.

5.2.3 Blade element momentum method

Using this method the flow area swept by the rotor is divided into a number of concentric ring elements and there is no radial dependency between them.

Each ring is divided into a number of tubes, which are independent.

The wind speed is assumed uniformly distributed over each ring element.

The forces from the blades on the flow through each ring element are assumed constant and it is equal to assuming that the rotor has an infinite number of blades.

The thrust on the ring element **T** of radius **r** and thickness **dr** from the disc defined by the rotor is:

$$dT = 2\pi r \rho u (V_0 - u_1) dr$$

V₀ is the wind speed before the rotor.

u₁ is the wind speed in the wake behind the rotor.

u = 1/2(V₀ - u₁) is the wind speed through the rotor plane.

When the tangential wind speed at radius **r** is zero upstream of the rotor and **u_w** in the wake, the torque **Q** on the ring element is defined.

$$dQ = 2\pi r^2 \rho u C_D dr$$

By introducing the axial induction factor **a** and the tangential induction factor **a'**, where **ω** denotes the

angular velocity of the rotor, the expressions for the thrust and the torque can be rewritten.

$$a = 1 - \frac{u}{V_0} \quad a' = \frac{1}{2} \frac{u_w}{\omega r}$$

$$dT = 4\pi r \rho V_0^2 a (1 - a) dr$$

$$dQ = 4\pi r^3 \rho V_0 \omega (1 - a) a' dr$$

At this point, it is necessary to make an initial choice for **a** and **a'**, for example **a = a' = 0**.

The flow angle **φ** is the angle between the rotor plane and the direction of the relative wind velocity **V_{rel}** on the rotating blade, shown in Figure A5.5.

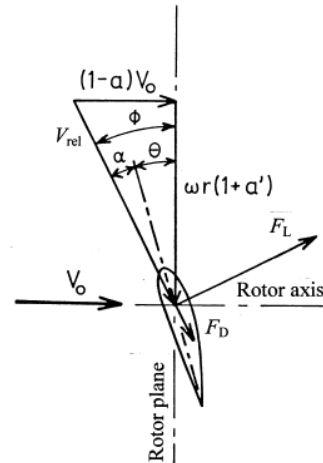

Figure A5.5: “Pitch angle”

$$\tan \phi = \frac{(1 - a)V_0}{(1 + a')\omega r}$$

The local inflow angle is **α = φ - θ**, where the pitch angle **θ** is the local pitch of the blade relative to the rotor plane. It is possible to transform **C_D** and **C_L** coefficient to normal and tangential ones.

$$C_N = C_L \cos \phi + C_D \sin \phi$$

$$C_T = C_L \sin \phi + C_D \cos \phi$$

The solidity **σ** is defined as the fraction of the cross-sectional area of the annular element that is covered by the blades. It depends on the radius and on the number of blades **B**.

$$\sigma(r) = \frac{c(r)B}{2\pi r}$$

$$a = \frac{1}{\left(\frac{4F \sin^2 \phi}{\sigma C_N} + 1\right)}$$

$$a' = \frac{1}{\left(\frac{4F \sin \phi \cos \phi}{\sigma C_T} - 1\right)}$$

$$F = \frac{2}{\pi} \arccos \left(e^{-\frac{B}{2} \frac{R-r}{r \sin \phi}} \right)$$

F is known as Prandl't tip loss factor.

If **a** and **a'** deviate significantly from the values assumed for the calculations go back to where the values were initially assumed and use the new value to calculate the flow angle **φ**.

This iterative procedure needs to be repeated until a convergent set of values for **a** and **a'** results.

SECTION 5 – LOADS AND LOADING CONDITIONS

Note that the momentum theory breaks down when a becomes greater than 0,3.

Whenever $a > a_c$ and $a_c \approx 0.2$ Glauert’s correction can be applied and a is replaced with the following value:

$$a = \frac{1}{2} (2 + K(1 - 2a_c) + \frac{-\sqrt{((K(1 - 2a_c) + 2)^2 + 4(Ka_c^2 - 1))}}{4 \cdot F \sin^2 \phi})$$

$$K = \frac{\sigma C_N}{\sigma C_N}$$

When a convergent set of a and a' is determined the Glauert’s correction can be used to calculate the local forces on a rotor blade at distance r from the axis of rotation.

The normal and tangential forces per unit of length are expressed below.

$$F_N = \frac{1}{2} \rho \frac{V_0^2 (1 - a)^2}{\sin^2 \phi} c C_N$$

$$F_T = \frac{1}{2} \rho \frac{V_0^2 (1 - a) \omega r (1 + a')}{\sin \phi \cos \phi} c C_T$$

The procedure is repeated for all ring elements modelled and the result consists of distributions along the rotor blade of the normal and tangential forces per unit of length.

5.2.4 Beam theory

Since rotor blades are slender, they, from a structural point of view, can be considered beams and the “beam theory” can be thus applied.

For analysis of a rotor blade by means of beam theory, the following definitions relating to the blade profile are needed:

- The elastic axis is perpendicular to the section and intersects the section in a point where a normal force will not give rise to bending;
- The shear centre is the point where an in-plane force will not rotate the profile in the plane of section.

The two in-plane principal axes are mutually perpendicular and both cross the elastic axis.

The principal axes are defined by the phenomenon that if a bending moment is applied about one of them, the beam will only bend about this axis.

Applying a bending moment about any other axis will induce bending, also about another axis than the one corresponding to the applied moment.

Figure A5.6: “Beam theory axes”

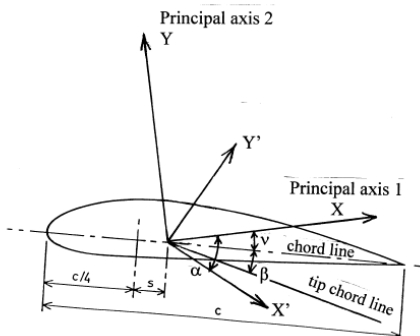

The angle α between the reference axis X' and the principal axis X can be calculated with the following formula where $[ED_{X'Y'}]$ is the deviation moment of inertia and $[EI_{X'}]$ and $[EI_{Y'}]$ are the bending stiffness properties about the X' and Y' reference axes, respectively.

$$\alpha = \frac{1}{2} \arctan \frac{2 [ED_{X'Y'}]}{[EI_{Y'}] - [EI_{X'}]}$$

$$[ED_{X'Y'}] = \int_A \mathbf{EX}'\mathbf{Y}' dA$$

$$[EI_{X'}] = \int_A \mathbf{EX}'^2 dA$$

$$[EI_{Y'}] = \int_A \mathbf{EY}'^2 dA$$

The bending stiffness about the principal axes can be now computed as follows.

$$[EI_X] = [EI_{X'}] - [ED_{X'Y'}] \tan \alpha$$

$$[EI_Y] = [EI_{Y'}] - [ED_{X'Y'}] \tan \alpha$$

Since present wind turbine blades are usually relatively stiff in torsion, the torsional stiffness is usually neglected.

In structural modelling and analysis, it is important to be aware of the flutter phenomenon, which may result from coupled torsional and flapping motion.

Low ratios of torsional and flapwise frequencies and high tip speeds indicate rise of flutter.

5.2.5 Control system

A control system is usually provided to keep the operating parameters of the wind turbine within specified limits.

The operating parameters are usually controlled by monitoring their current values and/or their first or second derivatives; a regulation algorithm can be set up and coded for use together with an aeroelastic code for load prediction.

The mechanical power of the wind turbine can be expressed as a dependent on C_p which is a function of the pitch angle β and of the tip speed ratio $\lambda = \omega_R R / u$, where, ω_R is the angular frequency of the rotor and R is the rotor radius.

$$P = \frac{1}{2} \rho A u^3 C_p (\beta, \lambda)$$

The pitch angle β and the rotor speed ω_R are the two parameters that can be used for the control of the turbine.

The control of the turbine can be based on one of the following two approaches:

- Optimize the power below the nominal power by choosing β equal to its nominal value β_{opt} and keeping λ constant at its optimal value λ_{opt} . λ cannot be controlled directly, since u is hard to measure, therefore ω_R is used as parameter to control the turbine.

SECTION 5 – LOADS AND LOADING CONDITIONS

- Limit the power by keeping it as close as possible to the nominal power.

By means of the pitch and speed regulation of the turbine, changes in the aerodynamic power are absorbed as changes in the angular velocity of the rotor instead inducing changes in the torque which is transferred to the gearbox.

SECTION 6 – SELECTION OF MATERIALS AND RELEVANT FABRICATION ISSUES

1 Introduction

Materials deemed appropriate by RINA with regard to workmanship procedures and service conditions are to be used for the construction of the wind turbine support structures and its stationkeeping system.

Relevant material specifications are to be provided for all structural materials intended for use in the construction of the floating wind turbine installation, considering all design phases and associated operating conditions.

2 Selection of steel material

2.1 General

The specification of selected steel material used in each part of the floating wind turbine installation is to be submitted to RINA for approval.

In selection of the appropriate steel properties for a given structural component, the following topics are to be considered, but not limited to:

- Consequences of failure (importance of the component for global unit safety);
- Presence of stress variation and/or stress concentration;
- Susceptibility to corrosion;
- Susceptibility to collision;
- Minimum operating air and/or water temperature,

In addition to the basic considerations relevant to stress level and component thickness.

In particular, the recommendations referred to in this Guide apply to materials with a maximum thickness of 70 mm. If thickness is greater than 70 mm, the materials are to be approved by RINA with the necessary modifications on a case-by-case basis.

For the determination of appropriate steel material grade selection, special attention is to be paid to all design situations in the life of the floater, since some conditions, different than the ones addressing the material selection for the operational phase, may govern the requirements, such as design temperature or the stress level during marine operations.

When specifying the properties required for a steel material, they are to include mechanical, chemical and manufacturing properties, as well as indications of relevant tests, including non-destructive tests.

The following properties are to be considered, but not limited to, as applicable depending on specific design requirements:

- Steel chemical composition and resistance;
- Mechanical resistance;
- Ductility properties;
- Toughness properties (with respect to operating temperature);
- Through-thickness properties (as applicable);
- Corrosion resistance;
- Fire resistance;
- Weldability.

Guidelines

(Ref. ISO 19904-1, Clause 9.9.3)

Transmission of tensile action effects through the thickness of a plate should be avoided as far as practicable, particularly in primary structural components. In cases where such actions cannot be avoided, the specification for the material shall include guaranteed through-thickness properties.

Workmanship procedures and welding processes shall be such that the properties and soundness of base materials and of the welded joints are consistently uniform. Relevant fabrication and welding specifications and procedures are to be approved by RINA.

In general, within the established limits of application, weldable steels that meet the requirements of RINA Rules for Floating Offshore Units at a Fixed Location and Mobile Offshore Drilling Units (RINA RES17) Part D Materials and welding, are acceptable.

As an alternative, also recognized by ISO 19904-1, Clause 9.9.2, steel properties shall comply with the design class (DC) approach addressed by ISO 19902; in light of that, steel characteristics required in [2.4] for the different classes, according to structural categories described in [2.2] are acceptable for structural application.

Approval of other types of steel with respect to chemical composition and mechanical properties is given by RINA on the basis of the specification of steel properties, applicable technological instructions and acquired experience.

Unless otherwise stated, manufacturing, testing, installation and use of materials are to comply with the requirements specified in the relevant Parts of the above mentioned RINA Rules RES17 or RINA Rules for Ships, REP4, Part D, materials and welding, as applicable.

2.2 Type of materials according to structural category

Materials for structural use are to be selected following to two methods defined in ISO 19902, Clause 19. These methods are generally referred to as:

- a) Material category (MC) approach
- b) Design class (DC) approach.

These two methods are mutually exclusive and once one of them is selected it is not interchangeable at any stage with the other. The flow chart of the selection process is given in ISO 19902, Figure 19.1.1.

Steels are to be selected as belonging to a strength and toughness class for the purpose of material selection and use in offshore structures:

- Strength groups are defined by a range of yield strength, determined by tensile testing (ref. [2.4.3]);
- Toughness classes are determined by the ability of steels to achieve a minimum Charpy V-Notch (CVN) test energy at a specified minimum temperature. Toughness becomes more important as the magnitudes of varying actions increase and as the

SECTION 6 – SELECTION OF MATERIALS AND RELEVANT FABRICATION ISSUES

criticality of the structure increases. The LAST (lowest anticipated service temperature) is to be considered in accordance with applicable regulatory requirements in the region of application; in lack of more appropriate determination, suggested values of LAST for some areas are given in A.19.2.2.4 of ISO 19902. Minimum toughness requirements for structural steels are defined in Table 19.4-1 of ISO 19902.

Following the Material Category approach (MC) the steel are to be selected on the basis of the designed yield strength and toughness level in combination with the structure exposure level (see Section 3, 1.2.1).

An appropriate material category can be selected according to the following recommendation in compliance with ISO 19902, Annex C Par. C1 (Note: only L2 and L3 are to be considered provided the conditions introduced in Section 3, [1.2.1]:

- MC1: this category is to be generally applied for exposure level L1 structures.
- MC2: this category is to be generally applied for exposure level L2 structures.
- MC3: this category is to be generally applied for exposure level L3 structures.

The required toughness class is determined by ISO 19902 Table C.1 of the Annex C according to the following guidelines:

- a) Type of component;
- b) The material category (MC) of the structure;
- c) The steel group, which is based on SMYS (specified minimum yield strength) as shown in Table 6-1, where the SMYS is previously defined along with the thickness by design analyses.

The Design Class (DC) approach for selecting the appropriate material strength group and toughness class is based on a component's criticality rating: DC1 to DC5, being DC1 the most critical.

If the DC approach is selected the provisions of ISO 19902 Annex D applies. In particular the required toughness class may be selected according to Table D.3 of such Standard.

2.3 Steel pipes

Pipes fabricated according to API 5L may be purchased, provided they satisfy all the requirements of this Guide. Pipes shall be of quality PSL2 ordered for offshore service, in accordance with Annex J of API 5L (with exception of grade A25), and may be seamless or longitudinally welded with SAW procedure up to a maximum diameter of 508mm (20").

Welded and seamless pipes shall undergo non-destructive examination according to the requirements of this Guide. The mechanical properties of the finished products are to be in accordance with the requirements of API 5L and the impact test requirements reported in [2.4.3] of this Guide.

Pipes for structural components are to be supplied in the normalised, quenched and tempered, TMCP or normalised rolled condition. U-Ing, O-Ing and

Expanding process (UOE) is acceptable. Spiral welded pipes are not allowed. The accepted steel production processes are basic oxygen and basic electric arc furnace.

Pipes fabricated according to ASTM A53/A53M may be purchased, provided that they satisfy all the requirements of this Guide.

2.4 Weldable Structural Steels

2.4.1 General Requirements - Manufacturing procedure - Finishing grade and tolerance

The steel is to be made by basic oxygen or basic electric arc furnace process. All steels are to be fully killed and made by fine grain practice.

Supply conditions of steel plates sections and hollow welded and seamless pipes are to be specified by the Manufacturer.

Intermediate or finished products, produced by the continuous casting route shall be examined for centre line segregation in accordance with the manufacturer's procedures and as agreed by the purchaser. This does not apply to seamless hollow sections.

The minimum rolling reduction ratio of material made by continuous casting for plate is to be 4:1 except for piling where it is to be 3:1.

2.4.2 Chemical Composition

The chemical composition for all the steel grades determined by ladle analysis is to comply with the values of applicable specification for the steel manufacturing.

Commonly used specifications for steel plates, steel shapes and steel tubulars are listed in Annex C and Annex D of ISO 19902 within the context of the MC or DC approach respectively.

In case that EN10225-4 is applied, relevant Table 4 is to be considered for plates, Table 6 for sections and Tables 8 and 10 for hollow welded and seamless respectively.

The actual specified chemical composition of each type of steel is to be submitted by the Manufacturer to RINA for approval.

Sampling and preparation of samples for the determination of steel composition shall comply with ISO 14284.

Tolerances of product analysis, regarding composition of ladle analysis, are to comply with international standards recognised by RINA.

For ladle analysis determined for each cast, the values reported by the steel manufacturer shall apply. Product analysis shall be supplied by the steel manufacturer when required by RINA.

2.4.3 Mechanical Properties

Steels are grouped according to the SMYS (Specified Minimum Yield Strength) level as presented in the following Table 6-1 according to ISO 19902 Table 19.3.

SECTION 6 – SELECTION OF MATERIALS AND RELEVANT FABRICATION ISSUES

Table 6-1 - Steel grades allowed according the SMYS

Steel Group	SMYS range requirements
I	From 220 MPa to 275 MPa
II	> 275 MPa to 395 MPa
III	> 395 MPa to 455 MPa
IV	> 455 MPa to 495 MPa
V	> 495MPa

In case that European Specification is applied, the SMYS requirements are to be selected according to EN 10225-4 (Tabs 5a-5b-5c-5d-7-9-10) and EN10025-2 (Tab 7-8-9), where the SMYS is defined for different product thickness and grade.

Minimum toughness requirements are to comply with those indicated in Table 19.4-1 of ISO 19902:2007, in consideration of the recommendations specified in its Clause 19.4.

Correlation of steel groups and toughness class for steel plates, structural steel shapes and structural steel pipes to US or European Specifications is introduced by ISO 19902:2007 in Table C2, C3, C4 or D4, D5, D6 respectively.

In case that European standards are applied, Charpy V-notch impact test requirements are to comply with the values of the EN10225-4 (Tabs. 5a-5b-5c-5d are to be considered for plates, Tab. 7 for sections and Tabs. 9-10 for hollow welded and seamless respectively) and EN10025 (Tabs. 7-8-9). These tables are to be applied both for the requirements of minimum energy (J) and tests temperature. Different Charpy V-notch properties other than those specified may be accepted by RINA according to equivalence criteria and based on the results of alternative toughness tests.

Additional toughness tests may be required by RINA for materials to be applied in severe conditions (e.g. high mechanical loads, low temperature) for special components. RINA may request the submission of some or all of the results of tests performed.

Tests are to be performed in compliance with EN 10225 10.2.5 or recognised international standards; testing conditions and extension are to be approved by RINA. Assessment of the mechanical properties including CV-N Impact tests may be required even after "stress relieving heat treatment", depending on the application. Testing temperature requirements may be increased by RINA for structural parts submitted to post-weld stress relieving heat treatment

When improved deformation properties perpendicular to the surface are required (see EN 101649), the average value of the reduction in area on tensile test specimens obtained in perpendicular direction with respect to the surface direction is not to be lower than 25% and the minimum value is to be not lower than 20%. In particular circumstances, the average and

minimum values may be required to be 35% and 25%, respectively.

2.4.4 Additional Requirements

Additional requirements are to be considered with reference to EN-10025 and EN-10225 Section 13 "Options".

Generally the following is to be satisfied:

- For plates and hot rolled sections fabricated in accordance with EN 10025-2-3-4 the options of section 13 with a possible exclusion for:
 - EN-10025-2 options 3-5--11-22-20 EN-10025-3-4 options 2-5-9-11a-13-14-30.
- For plates and hot rolled sections fabricated in accordance with EN 10225 options 2-6-7-9-10-11-12-13 (for quality Z).

The Designer shall indicate for each of the above specified options whether the requirements is selected or not and to document a rational for the exclusion.

Design is to cover the following additional requirements:

- Steel for quality Z for thickness above 50mm is to be produced with special manufacturing process including vacuum degassing, desulphurisation and calcium treatment;
- Steel EN-10225 for quality Z is to be additionally tested in accordance with EN-10164 Class Z35 and proving at least 80% of the specified ultimate strength;
- A restricted Ladle and product analysis are to be agreed at the time of the order for steel when design class DC1 and DC2 (defined as ISO 19902) and Z quality (defined as EN10025 and 10225) are selected. The content of P and S is to be agreed at the time of the order;
- Plates EN-10025 of quality Z and thickness higher than 50 mm to be ultrasonically tested on the edges in accordance with EN-10160 and applying acceptance criteria S1/E2 for quality Z and S0/E1 for other plates;
- Hot rolled sections are to be inspected in accordance with EN-10306 with quality class 1.2 and 2.1 for design class DC1, DC2 and DC3;
- Steel plates for quality Z are not allowed to be repaired by welding.

2.4.5 Tests

Tests are to be performed on the material upon delivery.

Inspection and testing procedures are to comply with EN 10225 paragraphs 9 and 10 and with ISO 10025 par. 8-9-10. In addition, a check of the properties on separate samples submitted to the same treatment may be requested for materials that are intended to be post-weld heat treated.

The type of check required is to be specified by the purchase order and agreed with RINA. If no check is specified, RINA reserves the right to subsequently request the check according to the alternative specified

SECTION 6 – SELECTION OF MATERIALS AND RELEVANT FABRICATION ISSUES

in above mentioned standards (EN 10225 and ISO 101025).

2.4.6 Material test certificates

Structural steel materials for components design class DC1, DC2, DC3 and DC4 are to be provided with material test certificate EN-10204 type 3.2. Other steel materials are to be provided with material test certificate EN-10204 type 3.1.

2.4.7 Material of existing structures

Assessment of structural steel materials of existing structures is to be performed by RINA for compliance with the requirements of the present Section of this Guide.

Steel materials manufactured, tested and certified in accordance with other internationally recognized standards are evaluated by RINA on the basis of their equivalence with these Rules. Deviations from the Rules are considered by RINA on the basis of documented engineering justifications provided by the Owner, the Designer or the Manufacturer. Final proof of structural integrity and fitness-for-purpose for desired life extension is to be considered the general basis for approval.

2.5 Fabrication and welding

Fabrication of steel structures is to be carried out in accordance with relevant provision of RINA Rules RES17 and RINA Rules REP2.

Structural welding is to be undertaken by properly qualified welders utilizing weld consumables and welding procedures approved by RINA or equivalent Recognized Classification Society.

3 SELECTION OF CONCRETE MATERIAL

3.1 General

For the selection of concrete materials reference can be made to NS 3473.E latest edition, which is particularly devoted to the marine environment.

The present paragraph provides a short summary focusing on issues which typically pertain to possible concrete components of the floating offshore structure. For all design purposes the designer should anyway refer to the specific standard adopted for these components, by considering that, notwithstanding the fact that concrete structures have been proven serviceable for many years in a marine environment, this environment is, in principle, hostile to concrete with reference to some durability issues.

One of the main characteristics influencing the durability of concrete is its permeability. With strong, dense aggregates, a suitably low permeability is achieved by having a sufficiently low water/cement ratio, by ensuring complete compaction of the concrete and by using proper curing methods to ensure complete hydration of the cement. The cement content

should be sufficient to provide adequate workability with a low water/cement ration so that the concrete can be completely compacted with the available means.

It is essential that the concrete be as dense as possible, so all components design and detailing should be such as to make it easy for concrete to be compacted around reinforcement and into corners of molds and forms.

The structural form and the shape of elements of the structure are of major importance. After a long period of use, slender prismatic members and angular structures are more prone to trouble than smooth flat or curved wall areas. Corners should be rounded or modified with splays.

Special attention should be given to methods of curing and their duration. It may be necessary to insulate the concrete so that it is maintained at a suitable temperature, or so that the rate of evaporation of moisture from the concrete surface is kept acceptably low, or both.

Construction and supervision must be such as to ensure a consistently high standard of workmanship.

3.2 Material requirements

3.2.1 Cement

Cement should be ordinary, rapid-hardening or sulphate-resisting Portland cement, or blended cement containing granulated blastfurnace slag or pozzolana, and should comply with the relevant standards.

In the submerged and less exposed atmospheric zones, ordinary Portland cement will normally prove satisfactory. In the splash and more exposed atmospheric zones, there is a greater risk of attack on the concrete by the sulphates in sea water, but experience indicates that with the high quality concrete normally used in sea structures, good long-term durability is obtained using cements with C3A contents up to 12%.

Cements which are not the Portland family, or which do not contain a major proportion of Portland cement should only be used after consideration of their special characteristics. Such cement should not be mixed with Portland or Portland-based cements.

High alumina cement should not be used.

3.2.2 Aggregates

Aggregates may be natural sand and gravel, crushed rock, lightweight aggregates or other materials which have been accepted for use by testing and/or experience.

Aggregates likely to undergo physical or chemical changes or to react with the cement are to be avoided. Aggregates should be of rough cubic or spherical shape. They should be of consistent quality and grading.

Marine aggregates should not be used unless the chloride salt content is at an acceptable level and

SECTION 6 – SELECTION OF MATERIALS AND RELEVANT FABRICATION ISSUES

unless the aggregate has a sufficiently low shall content.

3.2.3 Water

Water should be clean and free from harmful matter. Wherever possible, it should be obtained from a public supply. Sea water should not be used in reinforced, prestressed or other structural concrete.

3.2.4 Admixtures

Air-entraining agents, workability aids and retarding agents may be used provided that suitable precautions are taken and it can be shown by tests that the product to be added will produce the required effect without in any way changing the other qualities required in the concrete or damaging the steel.

Calcium chloride or admixtures or pigments containing more than 0.1% chloride ion shall not be used

3.2.5 Reinforcing steel

Plains bars, deformed bars and welded fabrics may be used provided that details of their size, mechanical properties and, if required, bond properties are supplied by the manufacturer.

3.2.6 Prestressing tendons

Prestressing tendons may be in the form of wires, bars, strand, or stranded cables of high strength.

The conventional yield stress (or proof stress), the resistance to fracture and the elongation should be guaranteed by steel manufacturer.

3.3 Durability issues

For durability, three zones of exposure should be considered:

Submerged Zones: that part of the structure below the splash zone. For structural components in the submerged zone, selection of concrete material should be undertaken with respect to:

- prevention of chemical deterioration of concrete;
- prevention of corrosion of embedded steel;
- abrasion.

Splash Zone: that part of the structure subject to repeated wetting by sea water and drying, see 1.2 of Section 13 for relevant definition. This zone may be taken as that the wave with a statistical return period of six months, when superimposed on the highest and lowest levels of spring tides. For structural components in the splash zone, selection of concrete material should be undertaken with respect to:

- freezing and thawing;
- prevention of chemical deterioration of concrete;
- prevention of corrosion of embedded steel.

Atmospheric zone: that part of the structure above the splash zone. For structural components above the splash zone, selection of concrete materials should be undertaken with respect to:

- freezing and thawing;
- prevention of corrosion of embedded steel;
- fire hazards.

3.3.1 Cement content

A minimum cement content of 400 kg/m³ should be used for concrete in the splash zone. Elsewhere the minimum cement content of reinforced or prestressed concrete should be 320 kg/m³ where the maximum size of aggregate is 40 mm, or 360 kg/m³ where the maximum size of aggregate is 20 mm.

Cement content in excess of 500 kg/m³ should not be used unless special consideration has been given to the increased risk of cracking due to drying shrinkage in thin sections, or to thermal stresses in thicker sections.

3.3.2 Water/cement ratio

For high-quality concrete of low permeability, the water/cement ratio should be less than 0.45 and preferably 0.40 or less subject to the attainment of adequate workability.

3.3.3 Strength

For concrete directly exposed to salt water or salt-water spray, the minimum characteristic cube strength at 28 days should be 40 N/mm². For concrete protected from direct exposure to the marine atmosphere, the minimum characteristic cube strength at 28 days should be 30 N/mm².

Where severe scouring actions is to be expected, the minimum characteristic cube strength at 28 days should be increased to 45 N/mm².

3.3.4 Temperature

Where the minimum dimension of concrete to be placed at one time is greater than 600 mm and especially where the cement content is more than 400 kg/m³, the use of cement with a slower release of heat of hydration or other methods to reduce the temperature or to remove evolved heat should be considered.

In cold weather, precautions should be taken to prevent frost damage to the concrete.

SECTION 6 – SELECTION OF MATERIALS AND RELEVANT FABRICATION ISSUES

3.3.5 Freezing and thawing

Where freezing of the hardened concrete may occur, air-entraining agents should be used to entrain controlled amounts of air to improve its resistance to frost damage.

Attention should be given to the appropriate pore size distribution of the entrained air and the spacing between pores in the hardened concrete. Sufficient frost resistance is normally obtained with an average air content in the fresh concrete of 4% to 7% for natural aggregates of nominal maximum size varying from 40 to 10 mm respectively.

3.3.6 Abrasion

If severe scouring action due to pebbles, sand or silt is expected, the coarse aggregate used in the concrete should be at least as the material causing abrasion and the fine aggregate content of the mix should be kept as low as possible.

3.3.7 Concrete cover to reinforcement

For heavy concrete structures, with a wall thickness of 0.50, or more, and subject to marine environments, concrete cover to the reinforcement and prestressing tendons should be related to the zone of exposure as follows:

- in the submerged zone, the nominal cover to the principal reinforcing steel and prestressing tendons should be not less than 60 mm and 75 mm respectively;
- in the splash zone, and in the atmospheric zone subject to salt-water spray, the nominal cover to the principal reinforcing steel and prestressing tendons should be not less than 75 mm and 100 mm respectively.

For thinner-walled structures and for structures which are not subject to the conditions given in the point above, the concrete cover to the principal reinforcement should be not less than:

- 1.5 times the nominal maximum size of aggregate, or
 - 1.5 times the maximum diameter of the reinforcement
- whichever is greater.

Where special protection, such as polymer impregnation of the concrete cover or permanent applied coatings, is used, the concrete cover may be reduced below that given above.

4 SELECTION OF MATERIALS FOR SOLID BALLAST

4.1 General

Materials used for permanent ballast for stability purpose in internal compartments of a floating offshore wind turbine installation are to be carefully selected and evaluated regarding their durability and long term

behaviour, in order to avoid effects compromising the global stability of the unit, e.g. liquefaction of saturated sands.

5 SELECTION OF MATERIALS FOR THE MOORING SYSTEM

5.1 General

The components of the individual mooring line or tether shall match one another in order to avoid the introduction of adverse effects, such as fatigue damage or corrosion, in the mooring or tendon system.

5.2 Selection of material for chains

Moorings chains and connecting links are to be manufactured in accordance with appropriate rules for offshore mooring chains, as indicated in appendix A.11.1.3 of ISO 19901-7.

5.3 Selection of material for wire ropes

Moorings wire ropes and end sockets should comply with the requirements of ISO 19901-7, Clause 11.1.2 and are to meet material, fabrication, and testing requirements in accordance with appropriate recognized rules for offshore mooring wires, as indicated in appendix A.11.1.2 of ISO 19901-7.

6 INSPECTION AND TESTING DURING FABRICATION AND CONSTRUCTION

6.1 General

General reference is made, in the following, to ISO 19904-1 Clause 9.11.2, reported as follows:

Quality control inspection and testing shall be performed to ensure compliance with the fabrication specifications.

Relevant consideration should be given to the importance of structural connection when determining the extent of the quality control, inspection and testing to be performed.

Inspection procedures shall ensure that fabrication, including any repairs is undertaken in compliance with drawings specification and procedures.

Inspection undertaken during fabrication shall, as a minimum, include the following:

- qualification and acceptance of fabrication procedures;
- qualification and acceptance of relevant personnel;
- material quality;
- dimensional control (including alignment);
- preparatory work (e.g. assembly and fit-up);
- welding;
- non-destructive examination;
- repairs;
- corrosion protection systems.

SECTION 7 – CONCEPT SELECTION

1 Introduction

The choice of floating versus fixed support structure for an offshore wind turbine unit has been considered for new wind farm projects depending on site water depth.. In general, floating support structures should be the most cost-effective solution for sites with water depth larger than 100m. The transition depth with respect to fixed support is in the order of 50-100 m.

There are several configurations of floating structures to support wind turbines at sea.

The different typologies for floating wind turbines support structures, and relevant stationkeeping technologies (mooring lines, tethers, anchors), are based on the state-of-the-art consolidated for the offshore oil and gas industry, in the development of spar, semisubmersible, and TLP platforms in particular. However, while the typologies are similar, the structures themselves are different and have different needs.

Indeed, whereas oil and gas industry require bigger but fewer structures, offshore wind will require installation of a large number of smaller structures, which impacts greatly on the design, fabrication, installation, and operational characteristics of the structures.

The configuration of the floating support platform shall anyway contribute to achieve the required platform-tower-turbine system stability.

As introduced in Sec 2, [3], in this guide four main types of floating support structures (see Fig. 2-4), relevant to the actual state-of-the-art, are considered:

- Barge : Buoyancy stabilized
- Semi-submersible : Buoyancy stabilized
- Spar : Ballast stabilized
- Tension Leg Platform (TLP): Tension legs stabilized

As introduced in the list, structures may be grouped into three general categories based on the physical principle that is used to achieve static stability.

Semi-submersibles and barges are examples of “buoyancy stabilized” structures as they depend on the volume of the submerged body.

The tension leg platform (TLP) is not stable without its mooring setup, which classifies it as a “mooring stabilized structure”.

SPARs are column-like structures that require heavy ballasting at the bottom of the platform to overcome tipping. Barge-type platforms behave similarly to semi-submersibles as they both depend on buoyancy combined with catenary mooring.

However, the barge has a larger waterplane area while the semi-submersible mainly utilizes columns.

Semi-submersibles, TLPs, and SPARs general characteristics are discussed in the following [2].

2 Main offshore wind turbine platform concepts: from O&G to wind

2.1 Introduction

This item introduces the structures designed for supporting the turbine assembly of floating offshore

wind farms. General considerations on hydrodynamics are made to provide an understanding of structural response to sea environmental loads.

Thus, buoyancy, mooring and ballast stabilized support structures are briefly discussed, based on characteristics and concepts used in the oil-and-gas industry since it provided the basis for most of the information that currently applies to offshore floating platforms.

Considering the newer field of wind power, additional aerodynamic loading signifies that the behaviour of similar platform types will differ in between the two industries.

Consequently, the knowledge needs to be updated and response models used in the offshore industry re-evaluated to focus on the combination of the hydrodynamic loading with aerodynamic loading.

2.2 Semisubmersible offshore wind turbine

Semisubmersible have been used by oil and gas industry since the 1960s. They have been proven suitable in terms of stability in waves, particularly against heave and pitch motion.

Besides the acting loadings, the platform size differs between the offshore wind and oil gas industry. Anyway, this platform type is considered one of the main concepts for design of floating support structure for offshore wind turbines.

The semi-submersible concept is made of columns, which provide the main volume under water, and connecting members, which provide structural integrity to the system as a whole.

The oil-and-gas industry uses large volume pontoons under the water and columns through the water level to carry the deck. Passing to wind turbine platforms, this concept evolved to suit new specific needs.

Since the payload of the wind turbine is lower and the required deck space is consequently reduced, the volume of the platform is reduced as well, to get economic feasibility.

Thus, the platform offers relatively small water plane area. The number of columns of wind turbine support structures changes, e.g., to three columns. Also, the distance between columns is reduced, with increasing stiffness, with positive effect on the single offshore unit structural integrity demand.

Being a buoyancy stabilized platform, which floats semi-submerged on the surface of the sea whilst anchored to the seabed with catenary mooring lines, it possibly achieve stability through the use of distributed buoyancy, by taking advantage of weighted water plane area for righting moment; a semi-sub platform often requires a large and heavy structure to maintain stability, but a low draft allows for more flexible application and simpler installation.

Wind turbines with a semi-submersible support have the peculiarity of being able to be constructed and commissioned near the coast and then transported to the offshore installation site. The columns may be braced, where the introduction of bracings increases

SECTION 7 – CONCEPT SELECTION

strength but introduces fatigue issues; that’s the reason why there are ‘braceless’ semisubmersible projects.

Fig 7: Semi-submersible concept

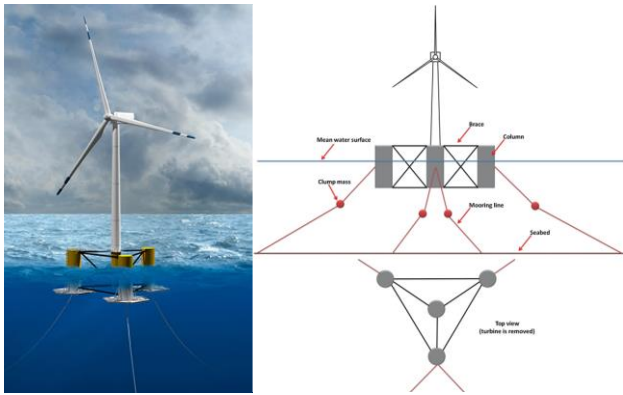

Fig. 7-1 shows the schematic layout of a semi-submersible wind turbine (with possible clump masses added to the mooring lines for the second configuration).

Semi-submersible floater stability is improved by increasing the wet surface area.

In general, they consist of 3 or 4 slender columns connected by pontoons and bracings. The righting moment depends on the area concerned by each column and the distance between the same columns, and proportionally increases as the distance between the center of gravity and the center of buoyancy increases; in any case, for the semi-submersible, the greatest contribution to the stability is given by the configuration and surface conferred in design to the columns.

To increase the wet surface means to increase the hydrodynamic forces and consequently the demand on structural capacity, as well as to increase the distance between the columns means greater stiffness requirements for bridges and bracings.

Regarding stability, semi-submersibles are stable to heave: the total weight of the structure is offset by the buoyancy. If the platform moves downwards, the volume of the added part of columns submerged apply a pushing force, bringing the platform to the initial position.

Pitch and roll are stabilized by the action of the righting moment. To stabilize yaw, surge and sway, it is required the contribution of the mooring lines. The mooring line thus contribute to stability, as well as containing the slowly motions, where the surge and sway frequencies are much lower than the wave frequencies. Even the yaw can have its own frequency much lower than the wave frequency region.

2.3 Tension leg (TLP) offshore wind turbine

The oil-and-gas industry initially developed TLP concept as a cost-effective way of exploiting deep waters. TLP stability is provided by taut mooring lines,

that are main feature of the TLP concept. Due to its resistance to motions provided by this extra stiffness, TLP was considered the most favorable solution for steady production in deep waters. However, mooring-related complications arise.

This type of platform is stabilized by the tension forces that are generated vertically in the legs, consisting of tether lines, due to the difference between the buoyancy and the platform total weight, difference that it is maintained in the order of 25%.

For offshore wind turbine support structures, the TLP concept (Fig. 7-2) may be broadened, to include different types of tether, stationkeeping arrangement and constraint in more/all degrees of freedom. In any case it consists of a central structure, sufficiently slender to reduce the hydrodynamic load, on which the tower with the turbine is mounted; some arms, or pontoons, extend from the main body supporting the tendons, or tethers, connected to the seabed by piles or gravity foundations.

The tendons are tensioned to provide stability. The number of arms and the angle between them may vary, usually being three or four. An option may be to have a configuration with a rigid cross-members made by the pontoons.

The use of the pontoons helps to reduce the size of the central column and therefore the hydrodynamic loading.

The structure would not be kept afloat because of the lack of buoyancy provided by the volume of the platform. By increasing the weight of the platform, aimed at submerging the platform deeper, extra stiffness is provided by increasing the tension of the mooring lines. Consequently, roll, pitch, and heave become highly restricted, such as TLP platforms behave like a fixed structure in these motions.

For wind turbine TLP offshore structures, the tendons have to be able to contrast the aerodynamic forces coming from the topside in addition to wave exciting forces. Considering the wave loads on the main body, the volume of the column is lower than buoyancy stabilized platforms, then the loads by incoming waves are reduced.

TLP design must have good coupling between the platform and the mooring system. While TLP provides the rigidity for efficient operation of wind turbines, installation and maintenance complexity shows to be its primary shortcoming.

The installation of the tendons system is normally one of the critical aspects in the realization of this type of structure: a system is to ballast the structure prior to transport to site, installation and remove ballast in connection with the installation of the tension legs . In this case, it is appropriate to study in depth the stability during all temporary phases, since it is possible that the metacentric height of the system is negative, or that the structure is not stable without the tendons.

The TLPs once installed have limited movement, with the obvious advantage of a good operation for varying wind regimes.

SECTION 7 – CONCEPT SELECTION

However, since the rigidity (which should be high enough to withstand the high hydro and aerodynamic loads) is mainly due to the tension in the legs, it must be ascertained that do not generate phenomena of resonance with respect to the elastic response of the column and to the dynamics of the rotor. Anchors gravity or suction piles may be used to secure the tendons on the ground of the sea bottom.

Fig. 7-2 : TLP concept

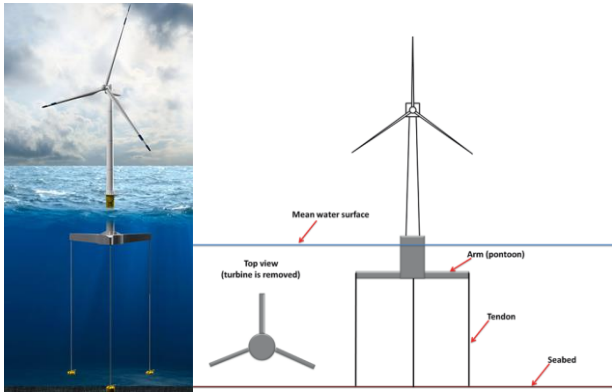

2.4 Spar offshore wind turbine

A spar buoy is a cylindrical ballast stabilized structure which gains its stability from having the center of gravity lower in the water than the center of buoyancy. This type of platform achieves stability by using ballast weights in the low part of the floater which creates a righting moment and high inertial resistance to pitch and roll, and usually enough draft to offset heave motion.

In general, a spar platform is ballasted with concrete or water in the lower compartments of the column. This lowers the center of gravity and increases the distance between the center of buoyancy and the same center of gravity. The tower and the turbine are placed on top of the spar.

Increased metacentric height helps increase the stability of the structure. The roll and pitch stabilizing moment are directly related to the metacentric.

Heave is controlled by the submerged part. The control of yaw and sway motions requires rigid mooring lines, fixed with an arm, for example a horizontal bar.

Regarding to yaw, there is no excitation of hydrodynamic type of this motion, instead generated by the wind load, then counteracted by the mooring lines, which, for the purpose, have to be connected to the slender column by arms.

A further option is to have the lines in the so-called 'delta' configuration. This configuration provides

recovery yaw moments appropriate in combination with masses 'clump' introduced, as to increase the tension, in the mooring lines.

The slender cylindrical column is susceptible to vortex-induced vibrations (VIVs. As the cylinder heaves, it creates vortices that alter the pressure distribution along the surface, and the flow becomes irregular. This pressure change leads to low-frequency vortex-induced vibrations, causing higher mean current forces and leading to fatigue.

The spar can be also adopted in moderate water depth, e.g. 100-150m, if appropriate considerations are made in the design regarding the stationkeeping system.

The limitation in the use of the spar in more shallow waters strongly depends on the size of the turbine.

Fig. 7-3 : Spar concept

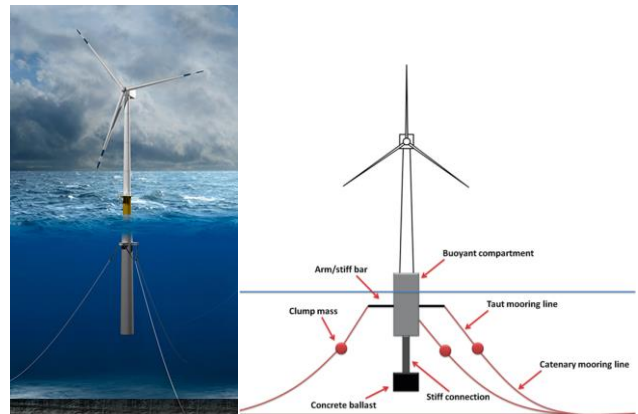

2.5 Mixed configurations

Some of floating offshore turbine projects have proposed alternative solutions possibly combining different basic configurations of floaters, thus obtaining hybrid solutions to capture, in principle, the specific benefits of each solution and cope with the challenges and requirements of which the production of wind energy offshore is evolving.

Any alternative or combined solution candidate for effective design should be preliminary subject to a feasibility study involving appropriate motion response analysis and relevant model tests.

2.6 Floating support structures comparison

For general reference, in the following Table 7-1, relevant advantages and disadvantages have been reported for the three possible floating support structures.

SECTION 7 – CONCEPT SELECTION

Table 7-1 : Advantages and disadvantages of three types of floating wind platforms

Type	Advantages	Disadvantages
Spar buoy—ballast stabilized	<ul style="list-style-type: none"> • Simple design facilitating serial fabrication processes • No active ballast required • Excellent stability 	<ul style="list-style-type: none"> • Constrained to deep water locations • Offshore installation of WT – costly - requires dynamic positioning vessels and Heavy-lift cranes • Large draft limits ability to tow the structure back to port for major repair
Tension leg platform (TLP)—mooring line stabilized	<ul style="list-style-type: none"> • Low structural mass • Onshore turbine assembly • No active ballast required • Excellent stability 	<ul style="list-style-type: none"> • High loads on the mooring and anchoring system • Challenging installation process
Semi-submersible platform—buoyancy stabilized	<ul style="list-style-type: none"> • Flexible application due to the ability to operate in shallow waters • Low installation vessel requirement—only basic tug boats required for installation • Onshore turbine assembly • Easy to access for port-side major repair 	<ul style="list-style-type: none"> • High structural mass to provide sufficient buoyancy and stability • Complex steel structures with Possible significant number of welded joints (fabrication, quality control and fatigue issues) • Potentially costly active ballast systems

SECTION 8 – GLOBAL PERFORMANCE ANALYSIS

1 GENERAL

Global analysis of the floating offshore wind turbine unit intended as a system is necessary to determine the global effects of the environmental conditions, eventually combined with other loads according to the DLCs and applicable considerations of Section 5 on its primary components, such as the tower, the hull structure of the floater, the stationkeeping system and the export electrical cable.

Global performance analysis is therefore introduced in this Section to address the specific verification issues relevant to the Floating Support Structure and the Stationkeeping System, covered in the following Sections 9 and 10 respectively.

The combination of the floating structure, stationkeeping system and export electrical cable is a complex integrated system responding to the environmental actions (wind and waves in particular). Therefore the global analysis of the floater cannot be separated from the analysis of the stationkeeping system, and overlaps substantially with the mooring analysis issue, covered by Sec 10, [2].

For floating offshore wind turbine installations, the typical action effects controlling the floater’s overall geometry and configuration, as well as the design of the stationkeeping system, include:

- Six degree-of freedom motions response of the floating support structure;
- Deck level and tower base level accelerations for determination of relevant inertial loads for structural design;
- Tower top level accelerations for RNA verification;
- Minimum and maximum mooring lines and tendons tension as well as export electrical cable axial forces;
- Global structural forces and moments on the floating structure;
- Hull hydrodynamic pressure loads for floater hull structural design;
- Clearance between passing wave crest elevation and possibly affected structures or equipment (such as the rotor blades) not designed for wave impact, for required air gap evaluation;
- Dynamic amplification effects (resonance peaks) evaluation.

The representative values of the above mentioned action effects may be obtained as outcomes of global dynamic analyses and/or model tests, as introduced in [2.5].

For a general comprehension of the global analysis effects on given offshore floater types, general reference can be made to the applicable provisions of the following standards:

- ISO 19904-1: 2019 for semi-submersibles, ship-shaped and spars;
- API RP2T for TLPs,

provided that the distinctive load and response characteristics of the floating wind turbine structures are taken into account, since these standards are

written for the oil&gas industry, from which the different typologies of floating structures for wind application have been adopted to a larger extent (ref. Sec 7).

In particular, the following provisions are to be specifically considered for the global analysis of floating wind turbine structures:

- P-D effects due to floater heel or trim, as generated by significant weight of the RNA, with relevant evaluation of environmental global bending and shear forces applicable to tower and substructure;
- Particular loads relevant to the specific type of floating structure, such as:
 - Global bending and shear of ship-shaped;
 - Splitting forces for semi-submersibles;
 - Global bending of spars;
 - Ringing of slender hulls due to wave or wind dynamic loads.

Moreover, particular attention is to be paid to:

- Meteorological conditions characterization, with appropriate consideration of joint occurrence of wind, wave, current and water level variation;
- Appropriate evaluation of dynamic interaction effects among the wind turbine (RNA) and the floater and, in turn, among the floating support structure and the stationkeeping system and/or the export electrical cable;
- Assumed duration of the time simulation required to adequately capture the statistics of the response, with particular reference to the issue of time scale difference between wind speed (typically 10 minutes) and storm waves (3 hours).

With regards to this latter issue, by making also reference to Table 5-1 of Section 5, for the DLCs requiring time domain dynamic simulation for the combined extreme wind and storm waves, the duration of the time simulation may differ from the reference period for the two relevant characteristic environmental parameters (i.e. the 10-minute wind speed and the significant wave height). Two scaling factors k_1 and k_2 (see *Notes to Table 5-1*) are therefore to be introduced in relevant DLC to take that time-scale difference into account.

With reference to IEC 61400-3, Section 7.4.6, $k_1 = 0.95$ for the 10-minute wind speed and $k_2 = 1.09$ for the extreme (50-yr return period) significant wave height are indicated as values to be used if one hour is the actual simulation time duration, as recommended. However, for floating wind turbine installation, different simulation time duration may be more appropriate, depending on specific floater design and site conditions. Therefore, TDA, as introduced in following [2.2.3], are to be carried out for a sufficiently long time to achieve stationary statistics, particularly for low frequency response adequate characterization. Multiple realizations of the same conditions may be necessary to generate appropriate data for the statistical analysis, as recommended in [2.2.3].

SECTION 8 – GLOBAL PERFORMANCE ANALYSIS

2 GLOBAL RESPONSE ANALYSIS METHODOLOGIES

2.1 Wave Induced Motion Response

The following three categories of response are normally significant to characterize the wave induced motion of a floating offshore wind turbine installation:

- First Order Motions: motions relevant to the six degrees of freedom, introduced in Fig. 2-5 of Section 2, at wave frequencies;
- Low Frequency Motions: motions induced by low frequency components of second order wave forces; These motions can be particularly significant in correspondence of the proper (natural) frequency of the floating installation and can address the design of the stationkeeping system
- Steady (mean) drift: mean wave drift force and yawing moment induced by the steady component of the second order wave forces.

For the TLP type support structure, high frequency heave, roll and pitch may also be significant, strongly dependent on different non-linear excitation mechanisms.

All the three types of responses can be evaluated by appropriate numerical motion analyses or model tests.

2.2 Global Loads and Response Analysis

2.2.1 General

A stochastic methods approach, either in the frequency or the time domain, is required to evaluate the global response of a floating offshore wind turbine installation subject to irregular sea states and random winds.

Both frequency domain- or time domain- analyses are part of a complex process eventually aimed at carrying out the structural assessment of the installation: for instance, spectral-based stochastic stress analyses are not able to establish proper correlation between external loads and internal stress; the stochastic approach can provide extreme values for the variables of interest, but without information relevant to phase relationships; one way to retain the phase information is to use a 'design wave (quasi-static or time-domain) approach', in which the extreme values computed from the spectral response analysis are used to identify one or more design waves. This method is recommended in the oil&gas industry for optimal structural design of offshore floating structures (see API RP2T) as, by using the design wave approach, the simultaneity of responses of global and local action effects can be accounted for.

With the Design Wave Approach, the peculiarities of the stochastic approach are maintained provided that the 'design waves' are calibrated on the extreme stochastic values of pre-determined critical response parameters, compatible with the specific structural configuration.

Particularly, for both semi-submersibles and TLPs support structure, it has to be considered that the maximum responses, to be determined for the

structural assessment, are often not governed by the maximum wave height and associated wave period: waves with shorter period often give the highest response, for instance the periods that give maximum split forces between the semi-sub or TLP columns.

2.2.2 Frequency Domain Analysis

Frequency domain analysis (FDA) refers to the solution of the equations of motion of a floating wind turbine installation by harmonic analysis or by Laplace and Fourier transformations.

The outcomes of a FDA are relevant to the variables of interest, such as floater motion and accelerations, as well as mooring line maximum and minimum forces, which are obtained in terms of amplitude and phases as functions of frequency via relevant response spectra.

The use of a FDA to evaluate the wave frequency response is implying a linear system approach where the linear wave theory is required, but alternative methods may be applied to evaluate the effects of finite amplitude waves.

A low frequency motion analysis is to be performed to determine the combined effect of wave drift forces and wind spectrum.

Damping values assumed in the analysis are to be accurately evaluated and documented.

High frequency springing response, if relevant, is to be evaluated in the FDA.

2.2.3 Time Domain Analysis

Since the FDA is a linear approach, unable to capture significant non-linearities in the response of a floating wind support installation to both aerodynamic and hydrodynamic loads, a more appropriate tool used for the dynamic response simulation of that unit is involving a time domain analysis (TDA), while the FDA is anyway considered for the evaluation of the hydrodynamic coefficients used as inputs in the TDA. THE TDA consists of a numerical solution of the rigid body equations of motion for the wind turbine floating unit, including its stationkeeping system, subject to the external environmental conditions (wind, waves and current in particular).

Since in the direct numerical integration of the equations of motion any nonlinear effect (such as drag induced forces, transient motions, finite wave amplitude effects, nonlinear characteristics of the mooring system) can be directly included, TDA is the preferable approach for global response analysis of a floating wind turbine installation.

From a TDA, the most probable extreme of the required response is to be predicted by using appropriate distribution curves fitted to the simulation outcomes, or other recognized statistical techniques.

TDA's are to be carried out by a multiple realization of the same conditions, able to generate adequate data for the statistical analysis, and for a suitable timeframe,

SECTION 8 – GLOBAL PERFORMANCE ANALYSIS

able to achieve the stationary statistics for the response, in particular for the low frequency response. For the TLP type floater, specific guidance, in order to properly consider in the TDA the significant ringing (high frequency vertical vibrations induced by impulsive loading) and springing effects (high frequency vertical vibrations due to cycling loading or resonance effects), is reported in the API RP2T Recommended Practice.

2.3 Floating Offshore Wind Turbine Installation Model

2.3.1 General

The analytical models are to properly include description of geometry, masses and loading conditions so as to adequately predict load effects, displacements and motions due to local and system effects, taking into consideration their dependency from time, drag loads, inertia loads and damping.

Because of the significant interaction in the global response among the RNA, the floater and the stationkeeping system (and, to some extent, the export electrical cable) an integrated – coupled – model, including all these components, is recommended.

As an alternative, uncoupled models for the 6-DOF rigid body floating support structure and for the slender components (mooring lines or tendons, electrical export cable) dynamics - where the floater's motions are introduced as boundary conditions - may be accepted, provided that coupling effects are appropriately taken into account.

Any analytical tool or software used for the dynamic analysis and global system response has to be shown as being capable of considering in a proper way all the interactions relevant to the system components and the external loads, and properly validated for the purpose, against industry-recognized software, applicable for similar conditions, and/or model tests (see [2.5]).

2.3.1.1 Uncoupled Analysis

Uncoupled analysis is possibly used to evaluate the system response of a floating offshore structure (ref. ISO 19904-1 Sect. 8.6) by a two-step approach:

- In the first step, the floater structure's rigid body response to static, low-frequency and wave-frequency environmental actions is computed. The mooring system and other slender or 'flexible' components (such as the exporting electrical cable) are represented by their static restoring force characteristics and a constant low-frequency viscous damping, whose evaluation is of paramount importance for the determination of the low-frequency floating structure motion analysis. The contributions from current direct action on mooring and other slender members may be represented by a constant external action on the structure.
- In the second step, the moorings and other exporting lines are analysed, considering both wave and current induced actions on the slender

members, and imposing the structure's wave-frequency (and low-frequency when applicable) motion response as forced dynamic excitation.

2.3.2 Coupled Analysis

In a coupled analysis all interactions between floating structure motions and slender structure response is accounted for by making a model of the whole system, including hydrodynamic action modules for slender components or motion suppression devices (e.g. heave plates). In particular there is no need for assessment of the low frequency damping from the slender members as this contribution is accounted for by their relevant dynamics.

2.3.3 Interface with the Wind Turbine

The coupling of the aerodynamic behaviour of the wind turbine with the hydrodynamic of the floating structure is to be carefully investigated.

Any software tool used for this purpose shall be validated against proper model or full scale tests.

During the operational phase of the unit, the global motion of the floater is affected to some extent by the rotating turbine. Therefore a control system is to be provided for the floater aimed at, when operating, limiting its motions and accelerations, significantly reduced by, e.g., roll and pitch wind damping effects.

The control system is made by software and algorithms designed according to the specific outcomes of model tests and advanced analysis.

A sufficient air gap shall be ensured between the crest of the design maximum wave height and the lowest blade tip position of the wind turbine installed on the floater. Relevant clearance, calculated with due consideration of the wave process and floater dynamics, shall be ensured by considering an allowance of at least 1m.

When an integrated (coupled) model is created for the global performance analysis of a floating wind turbine installation, coupling effects among the responses of the turbine RNA, the floating support structure, the stationkeeping system and the export electrical cable can be taken into account at every time instant (i.e. each incremental analysis time step). A more realistic simulation of the effects of a turbine control system and turbine's operating conditions can also be achieved by an integrated model.

2.3.4 Undesirable effects

Non linear mechanisms can trigger action effects interacting with particular natural frequencies of the global system normally not excited by wave frequency actions. As these resonant effects are often present in conjunction with low damping levels, particular attention is to be paid in the model to eventually predict these effects.

Being the amplitude of the response at resonance very sensitive to the damping estimates, the use of model tests is particularly recommended to consider these

SECTION 8 – GLOBAL PERFORMANCE ANALYSIS

complex situations and to eventually validate the analytical computations.

For slender components, Vortex Induced Motion or Mathieu Instability effects may typically occur as the result of large heave motion if the natural period of heave is approximately equal to either the half of the natural period of roll or the half of the natural period of pitch. Mathieu Instability effects have been also recognized for floater concepts with abrupt changes in water-plane stiffness and metacentric height.

In order to verify that effects like Mathieu Instability or Vortex Induced Motion are not affecting the response of the floating wind turbine installation, or are containable, relevant model tests are recommended.

2.4 Air Gap

Similarly to what prescribed in [2.3.4] for the required clearance between blades and passing waves, also for the topside deck and tower structures, if they are not specifically designed for direct impact of waves, appropriate clearance is to be ensured with respect to the design maximum wave height, for all afloat modes of operation.

A minimum air gap of 1.5m is to be provided between the 50-yr maximum wave elevation (above the highest still water level) and the lower edge of the floater structures not designed for wave impact, by taking into account wave run up effects and floating structure motions.

Under the survival load cases (SLCs introduced in Sec 5, [4.3]) the air gap is not to be lower than zero.

The required air gap can be calculated either by appropriate global performance analysis or, preferably, by model tests.

2.5 Model Tests

Estimates of the system response to be used for the design under the prescribed environmental conditions can be obtained by model tests.

Model tests can also be used either to validate analytical predictions or to determine response not directly reliably calculable, particularly for an innovative design.

Model tests and numerical simulations are to complement each other.

When comparing the results of model tests with analytical predictions, the following potential source of discrepancies should be considered (ref. also ISO 19904-1):

- Scale effects, such as those affecting Reynolds number, fluid interface and turbulence;
- Viscous effects (Reynolds number-dependent fluid drag and lift components);
- Wave reflections from side walls, induced by radiated and reflected incident waves;
- Limitations in the accuracy of modelling physical and geometrical parameters;
- Assumptions made in the analytical model and numerical simulation, particularly for mooring system response and impact loads assessment.

SECTION 9 – DESIGN OF FLOATING SUPPORT STRUCTURES

1 INTRODUCTION

This section is providing general guidance on structural strength analysis and verification of floating support structures constructed in steel (item [2]) based on the Load and Resistance Factor Design (LRFD) format, while [3] is covering concrete structures.

The Working Stress Design (WSD) format may be alternatively used, provided that it is supported by appropriate reference rules and standards consolidated for the design practice of specific floating support structures and the format is applied for the whole design of the structures, without mixing LRFD and WSD provisions. In addition to what reported in [A3.1], for background information on the peculiarities and similarities of the two formats reference can be made to Clause A.9.7.1 of EN ISO 19904-1.

Special considerations with reference to given type of floating support structure are reported in [4].

The structural design is to be based on the general requirements and guidance concerning loads and global behaviour reported in Section 5 and Section 8 respectively.

In particular the loading conditions described in [4.2] of Section 5 are to be applied.

2 PROVISIONS FOR STEEL STRUCTURES

2.1 General

2.1.1 Material properties and durability

Steel structures of the wind turbine floating supports are to be manufactured by materials selected on the basis of the requirements of Sec 6, [2].

Structures of the wind turbine floating supports are to be protected from corrosion by coating or other protection measures, whose design, covering the expected service life of the structure, may be carried out according to recognized international standards such as NACE SP0176 and SP00108, in line with the applicable requirements of Section 13.

2.1.2 Accessibility for inspection

In the design of the hull of the floating support structure, appropriate consideration is to be given to providing access for inspection, for both the phases of fabrication and service.

Particular consideration is to be given to accessibility, for surveys expected after construction, for those structural details that may be considered, based on experience and design considerations, more critical for the fatigue and corrosion issues.

2.2 Strength design criteria

2.2.1 Design Loading Conditions

The stresses on steel structures of the unit are to be evaluated assuming the design loadings specified in

Sec 5, [4.2] in their most unfavourable combination that may be reasonably anticipated.

Representative values of actions in the LRFD format shall be increased by the load factors reported in Table 5-2 of Section 5.

2.2.2 Resistance Factors

Resistance factor γ_R for the ULSs are to be applied according to relevant codes and checks adopted for the structural component checks, as indicated in [2.4.2].

Design against FLS is based on a format which makes use of an overall Design Fatigue factor (DFF) to be applied to a cumulative damage, evaluated according to the recommendations reported in [2.5.7] c) and relevant Table 9-1.

Unless otherwise specified, material factor for the ALS and SLS are to be taken as $\gamma_R = 1.0$.

2.2.3 Design Scantlings

The definition of design scantlings for a floating structure as reported by ISO 19904-1, Clause 9.3 is adopted:

- a) *When assessing global hull girder properties:*
 - *For strength design, design scantlings shall be defined as the as-built scantlings, or those intended for such purposes, with 50% of corrosion additions/allowances deducted;*
 - *For fatigue design, design scantlings shall be defined as the as-built scantlings, or those intended for such purposes, with 25% of corrosion additions/allowances deducted.*
- b) *When assessing local properties (e.g. plates, stiffeners, girders):*
 - a. *For strength design, design scantlings shall be defined as the as-built scantlings, or those intended for such purposes, with full corrosion additions/allowances deducted;*
 - b. *For fatigue design, design scantlings shall be defined as the as-built scantlings, or those intended for such purposes, with 50% of corrosion additions/allowances deducted.*

When computing bending stresses on ordinary stiffeners, side plating and on girders, the effective sectional area is to be calculated in accordance with "effective width" concepts reported by RINA Rules REP2.

The effect of notches and other structural details which may cause stress concentrations is to be carefully taken into account in the design of structures.

For structural members within the "splash zone" as defined in 1.2 of Section 13, the thickness reduction due to corrosion is to be considered. The amount of such reduction is to be decided case-by-case depending on the characteristic environmental factors, the materials used and the arrangements adopted for corrosion prevention

SECTION 9 – DESIGN OF FLOATING SUPPORT STRUCTURES

For elements located above the mean still water level, the above-mentioned reduction may be shortened up to zero, provided that in the Operating Manual periodical maintenance of the splash zone protective coating is foreseen and shown suitable for preventing coating deterioration and the protective coating is not subject to removal risks due to impacts or abrasions.

2.3 Structural analysis

2.3.1 Response evaluation

The floating support structure is to be investigated with respect to the following possible effects:

- material yielding and ductile fracture;
- overall or local buckling;
- fatigue;
- brittle fracture;
- excessive deformations;
- excessive vibrations.

Calculations relevant to structural analysis are to be performed for all the design phases of the structure. Structural analysis shall include consideration of actions occurring at interfaces of all relevant topside and mooring systems.

The effects of the actions factored according to table 5-2 of Section 5, derived from an analysis including the DLCs provided by Table 5-1 of Section 5, are to be used to check the adequacy of all the components of the floating support structure.

The following limit states are specifically to be evaluated:

- yielding (ULS), according to the provisions of [2.4];
- global and local buckling instabilities (ULS), according to the provisions of [2.4];
- fatigue failure (FLS) , according to the provisions of 2.5,

in addition to the ALS checks applicable to the floater design, in accordance with relevant DLCs provided by the mentioned Table 5.1.

2.3.2 Methods of Analysis

Linear elastic and/or non-linear structural models may be used to determine response for ULS design checks. Both non-linear structural models and simplified methods (depending on the extent of the accidental or abnormal event) may be used to determine response for ALS design checks.

Parts of the structure consisting of slender components should be analysed by a 3-D space frame model to determine internal forces and moments for structural members and joints checks. The effects of joint eccentricity and flexibility, when significant, is to be accounted for.

Parts of the structure consisting of large-volume components such as plate and shell structures should be analysed by a 3-D shell model, in combination with frame models as appropriate. Where plate and/or shell panel buckling can reduce cross-sectional

effectiveness, this shall be considered in the model. When the accuracy of deflections is important, this must be reflected in the model as well.

In general, the response of a floating support structure can be considered as being driven by two categories of response:

- global response, relevant to a global analysis, also addressed in Section 8, which require a global structural model that simulate the effects of global actions on the structure, evaluate the structural response of the primary structure and identify controlling load cases for the local analysis models, relevant to the following
- local response, relevant to analyse the effects on the structure of local actions such as hydrostatic pressures, tank pressures and concentrated actions.

For specific requirements and guidance to be applied for global and local models reference can be made to ISO 19904-1 Sections 9.4.2 and 9.4.3 respectively.

In any case, each model extent should be defined such as proper actions and appropriate boundary conditions are included to reflect correct interfaces modeling.

2.4 Strength assessment

2.4.1 General

Structural design checks are to be carried out and properly documented for verification of all the floating support structure components, as well as local structures capacity and integration with main hull structure

Particular attention is to be paid with respect to local strength and performance along the service life of the following components:

- structure supporting mooring system components, which shall withstand, as a minimum, the action corresponding to a mooring line loaded to its minimum breaking strength;
- scantlings associated with structural discontinuities and major changes of cross section;
- structures immediately surrounding large openings, if any. At openings, continuity of primary longitudinal components shall be maintained as far as practicable, and reduction in hull section modulus shall be minimized and compensated for;
- thickness of internal structure in location susceptible to excessive corrosion;
- details of the ends and intersections of components and associated brackets;
- shape and reinforcement of slots and cut-outs for internals;
- Elimination or closing of weld scallops associated with butt welds;
- Toes of ‘softenong’ brackets used to reduce the effects of abrupt changes of section or structural discontinuities.

SECTION 9 – DESIGN OF FLOATING SUPPORT STRUCTURES

2.4.2 Structural components check

Design of structural members of the floating support structure is to be carried out for providing adequate scantlings with respect to representative values of structural strength.

Design of plating and stiffened panels is to be carried out in general for providing their minimum scantlings with respect to yield strength.

The representative value of yield strength may be taken as the nominal value from the requirements of RINA Rules REP2 or the nominal value taken from the standard to which the material is specified. Relevant tensile tests should be carried out in accordance with the Standard referenced in the material specification to validate the nominal value of yield strength assumed in the design.

Shear yield strength may be taken as $(1/\sqrt{3})$ times the yield strength.

Plates are to be checked against buckling stability.

Buckling strength shall be based upon RINA Rules REP2 or equivalent Recognized Classification Society (RCS) code formulation; any design format utilized for structural members in compression shall take into account that local or overall elastic buckling can occur before the component reaches its design strength.

Relevant requirements for minimum thickness and/or design of a flat plate or a cylindrical shell structure can be found in RINA Rules REP2 Part B, in addition to the applicable requirements of ISO 19904-1, Clause 12.3 and Clause 13.3, for semi-submersibles and spars respectively, or API RP2T for TLPs, with appropriate values of material factors to be introduced accordingly, if a LRFD format has been adopted in the design, or, alternatively, the safety factors reported in relevant provisions for the WSD approach.

For design of tubular members and relevant connections, resistance factor and member strength capacity equation checks may be determined according to ISO 19902 for fixed offshore structures.

For the design of non-tubular beams, columns and structural members with other types of sections within the scope of the EN 1993-1-1, buckling and strength checks capacity equations may be determined based on the relevant requirements. In case that EN 1993-1-1 is used, relevant material factors $\gamma_{m0} = \gamma_{m1} = 1.10$ are to be used.

2.4.3 Tower/Hull interface

In general the design of the RNA support (tower) structural arrangements may be carried out according to the principles and criteria provided by IEC 61400-3, considering the site-specific environmental conditions and the applicable DLCs, for the same limit states as for the hull structural design.

Special consideration for RNA tower structural design is to be given to the issues relevant to the interface with the floating support structure, such as:

- Inertia components caused by global rigid motion;

- Relative deflections in all three translation directions (for instance hull deflections acting on tower supports);
- As-built deflections from fabrication tolerances at hull/tower interface;
- Maximum angles of inclination, for both the intact and damaged conditions;
- Effects from green water and wave slamming effects;
- Second-order (P-D) bending effects;
- Local dynamic effects induced by wind turbine-induced vibration or vortex shedding.

In particular the tower structural design and relevant interface assessment shall be based on a dynamic analysis of the tower that can be carried out by a modal analysis, where the eigenvalues (eigenfrequencies) of the tower shall be calculated based on a structural model considering the entire floater. The proper (natural) frequency of such a system shall be then compared to the critical ranges of turbine operation (1P, 3P, etc.).

2.5 Fatigue assessment

2.5.1 General

Cyclic loads (due, for instance, to wave and/or wind loads) can cause cumulative damage in the materials of the structural components, eventually leading to structural failure by fatigue.

This item is relevant to the fatigue assessment that is to be performed to verify adequate capacity against cyclic loading, mainly due to waves, for the floating support structure.

For fatigue analysis of the RNA and tower, mainly caused by wind, general reference can be made to IEC 61400-3, Subclause 7.6.3 for RNA, and IEC 61400-1, Subclause 7.6.3, for the tower.

2.5.2 Design fatigue life requirement

The design life of any structural member subject to fatigue assessment is to be not shorter than that of the anticipated service life of the floating offshore wind turbine installation, normally not less than 20 years, times the safety factor for fatigue life, i.e. Fatigue Design Factor DFF of Table 9-1.

2.5.3 Fatigue sensitive components and connections

The fatigue analysis is to be mainly performed for structural components on which stress concentrations are expected.

Particular attention is to be paid to structural members and connections that are difficult to inspect along with the service life of the installation or structural parts where the influence of cyclic loads on the corrosion may be significant.

SECTION 9 – DESIGN OF FLOATING SUPPORT STRUCTURES

Both inspectability and corrosion protection issues are to be considered in setting the DFF to be used (see Table 9-1).

The following components are known to be particularly sensitive to fatigue action for floating offshore structures from the industry practice (ref. ISO 19904-1 Clause 10.13):

- Foundations of equipment subjected to high cyclic loads, such as mooring winches, chain stoppers and, for the present subject, the foundation for the wind tower;
- Structural details at interface of the mooring system with the main hull structure;
- Main hull shell, bottom, decks;
- Main hull longitudinal and bracket connections to transversal frames and bulkheads;
- Openings in main hull.

For the fatigue assessment of the mooring systems and their point of attachment to the floating support structure, reference can be made to ISO 19901-7 as applicable.

2.5.4 Loading conditions

Fatigue analyses are to be carried out by using an input capable to describe the cyclic loads in the long term, i.e. representing the loading history of the floating support structure during both pre-service (if significant) and in-service phases.

Appropriate scatter diagram, loading spectra or time series may be used depending on the methodology used for the fatigue assessment.

The loading conditions for the fatigue assessment are to be in accordance with Section 5, specifically the DLCs reported in Table 5-1, where the type of analysis is indicated as 'F' in the last column, as a minimum set of load cases, to be further implemented by fatigue local analysis for structural details that can be anticipated as fatigue sensitive, depending on the type of floater.

The load factors are to be taken as 1.0 for all the DLCs used in the fatigue assessment.

2.5.5 Fatigue methodology

Fatigue analysis can be performed using different methods, mainly in the frequency (linearized spectral analysis) or time (non-linear time domain analysis) domain.

Further, the verification criterion in a given structural detail depends on the methods of analysis, of which two different categories exist, i.e.:

- methods based on fracture mechanics;
- methods based on the evaluation of the cumulative damage based on S-N curves.

For offshore floating structures, the spectral method is the most relevant and recommended one, however, where non-linearities dominate, it is necessary to resort to time domain methods, which can, in turn, allow the development of linear empirical results that can be incorporated into a spectral method.

As regards to the two formats mentioned for the specific assessment of the structural detail, the method based on the S-N curves (Miner's rule) is considered the standard design practice whereas fracture mechanics analysis (FMA) methods are employed to quantify fatigue lives of structural details for special cases. For FMA applications reference can be made to BS 7910.

2.5.6 Fatigue analysis

Fatigue analysis shall proceed as a series of spectral fatigue analyses (SFA), linearized as necessary to cover different operating conditions, as described in the following.

Any resonant rigid body response is to be accounted for in the structure's motion analysis.

Special consideration of further dynamic or non-linear effects due to e.g., slamming or turbine vibrations are to eventually be taken into account by involving time domain analysis, if possible.

Relevant model tests may be used in this respect or in lieu of an analytical fatigue assessment, if it is shown that they are suitable for the specific design situation.

For any structural detail subject to fatigue assessment, a set of spectral fatigue analyses is to be performed according to the following main steps, any analysis carried out on an appropriate structural model, representing given operating conditions to which the detail can be exposed throughout its planned service life:

- evaluation of the cycling loads effects by determination of distribution of stress ranges for each modelling configuration;
- determination of fatigue resistance;
- calculation of expected damage accumulation and fatigue design life.

2.5.7 Evaluation of cycling loads effects

A detailed evaluation of the cycling loads effects involves a further number of steps, which can be generally described as:

- Environmental loading data characterization;
- Structural modelling;
- Hydrodynamic analysis;
- Response amplitude operators determination;
- Determination of stress range at given location (hot spot stress range), prone to fatigue damage accumulation.

For further description of any of these steps, general reference can be made to ISO 19904-1 Clauses from 10.4 to 10.8, by highlighting that some of these steps can be typically performed in connection with other main aspects of the floating support structure design process.

The cumulative damage at a given location of a structural detail (or connection) is commonly determined using the Palmgren-Miner rule and it requires knowledge of the following main factors:

- Stress range at that location;

SECTION 9 – DESIGN OF FLOATING SUPPORT STRUCTURES

- Number of applied cycles of a particular stress range magnitude;
- Fatigue resistance of the material.

a) Stress range at a location

A global analysis model is normally used to determine nominal stress ranges in the vicinity of the location.

Nominal stresses are determined based on the section properties of the component under consideration, then the ‘hot spot’ (or geometric) stress is determined at specific locations of the connection by multiplying the nominal stress by the appropriate Stress Concentration Factor (SCF) and then combining the axial-, in-plane bending- and out-of-plane bending-stress components, accounting for any phase differences.

Consideration should be given to the inclusion of the additional stress intensity effects due to the gross geometry of the joint (e.g. stress raising from presence of holes or local through-wall bending effects).

The SCF generally depends on the structural local and global geometry. Appropriate values of SCFs, consistent with the assumptions made to the relevant S-N curve (see [2.5.7] c)), may be derived from FEA, laboratory tests or empirical parametric formulae based on such methodologies.

b) Stress range counting and distribution

Execution of the fatigue assessment by the SFA method ([2.5.6]) results in a stress transfer function for each critical detail or location under consideration; by applying, for wave induced fatigue for instance, the wave spectrum representing each design sea states (from the scatter diagram, with given Hs and Tz, and relevant number of cycles n), the stress spectrum for any of such short-term conditions can be determined for each critical detail or location.

Where the short-term response is narrow-banded, the stress range may be assumed to follow a Rayleigh distribution. This assumption is commonly used, being conservative (ref. ISO 19904-1).

More general examples relevant to the assessment of the distribution of stress ranges and number of cycles are reported in A.10.9 of ISO 19904-1.

A rain-flow counting method can be used to deal with the combination of low-frequency and wave-frequency stress cycles.

More in general, the cycle counting methods are used to establish distributions of stress ranges from a stress history. Several methods may be used, among them:

- Peak counting
- Range counting
- Rain-flow counting

These three counting methods give the same result for a pure sinusoidal stress history and for an ideal narrow-banded stress history.

In the rain-flow counting method, the stress history is first converted into a series of peaks. This method is not restricted to high-cycle fatigue but can also be used for low-cycle fatigue where strain range is the important parameter. The resulting stress range distribution from cycle counting by the rain-flow method is represented as a matrix with one row for each mean stress level and one column for each stress range. Each element of the matrix will contain the number of stress cycles associated with a particular stress range and a particular mean stress.

c) Fatigue resistance

Fatigue resistance is to be characterized by using recognized methods such as the method based on fatigue tests (S-N curves).

The S-N curve is established through numerous sample tests with different load ranges, resulting in pairs of stress range S and a number of stress cycles N to failure at that given stress range.

Suitable S-N curves may be selected, with particular attention being paid to the application and limitations of these curves, by RINA Rules RES17/E, as applicable, or recognized RCS for fatigue assessment of offshore floating structures, where characteristic S-N curve for typical structural detail categories (typically depending on global and local geometry, and relevant fabrication issues) are provided for the application:

- In air;
- In seawater without corrosion protection;
- In seawater with cathodic protection.

The application of the S-N method shall account for the effect of coatings, the presence of corrosion protection measures and large plate thickness, as appropriate, in addition to the consideration of the specific type of metallic material (that is affecting the slope – provided by the m parameter – of the ‘curve’ – represented as a straight line in the adopted logarithmic format) for which the S-N curves have been derived.

2.5.8 Cumulative damage evaluation and fatigue safety check

The cumulative damage is commonly determined using the Palmgren-Miner rule, according to such a rule, the accumulated damage **D** can be predicted as follows.

Given a specified stress range **S**, the S-N curve gives the number of cycles **N** to failure. The accumulated damage **D** can be interpreted as a sum of partial damage owing to load cycles at various stress ranges, regardless of the sequence in which the load cycles occur.

$$D = \sum_{i=1}^k \frac{n(S_i)}{N(S_i)}$$

In which **n** denotes the number of stress cycles of stress range **S** in the lifetime of the structure, and **N** is the number of cycles to failure at this stress range.

SECTION 9 – DESIGN OF FLOATING SUPPORT STRUCTURES

The sum is overall damage *D* in a sufficiently fine discretization of the stress range distribution into *K* blocks of constant range stress cycles.

$$\log N = \log K - m \cdot \log S$$

K Empirical material constant determining the level of the S-N curve

m Slope of S-N curve

The total damage is the cumulative damage in service plus the cumulative damage arising from other phases in the life cycle, i.e.:

$$D_{Total} = \left(\sum D_{in-place\ phases} + \sum D_{other\ phases} \right) * DFF \leq 1$$

where

D_{Total} is the total accumulated damage ratio throughout the life-cycle;

$\sum D_{in-place\ phases}$ is the accumulated, unfactored, damage ratio during the in-place operational phases;

$\sum D_{other\ phases}$ is the accumulated, unfactored, damage ratio during other phases in the life cycle;

DFF is the Design Fatigue factor, a safety factor to be applied in accordance with the following considerations.

The safety factor DFF depends on the location of the structural detail and on the accessibility for inspection and repair, in addition to the importance of the detail with respect to the global integrity of the structure, being it critical when the failure of the structural component would result in substantial consequences as rapid loss of the whole integrity of the installation, as well as significant economic effects (in terms of costs due to repair and downtime of the plant), these latter particularly when a common type of detail subjected to similar action effects is used extensively throughout the structure.

Minimum requirements for the design fatigue factors are reported in the following Table 9.1, based on the main assumptions that the floating structure is unmanned and inspections are carried out at intervals of maximum 5 years.

Table 9.1 – Design Fatigue factors DFFs

Importance	Degree of accessibility for inspection and repair		
	Not accessible	Underwater access	Dry access
Non-critical	3	2	1
Critical	5	3	2

Reductions in the factors presented in Table 9-1 for inspectable joints may be used, provided an appropriate in-service inspection strategy is adopted.

At the request of the Owner, RINA reserves the right to accept permissible values of the cumulative damage higher than those listed above.

Dry access in the table 9-1 refers to fatigue sensitive locations where the possibility for close visual inspection and repair in dry and clean condition is effective, otherwise the DFF shall be that appropriate for underwater access or not accessible.

Where crack propagation is likely from a location with a given degree of accessibility for inspection and repair to a location more difficult to access, the latter shall address the choice of the appropriate DFF.

Along with the application of the DFF reported in Table 9.1, any other load and resistance factor adopted in the LRFD format for the FLS are to be set equal to 1.0.

2.5.9 Fatigue assessment for prior service

Fatigue requirements in relation to aged and/or reused structures for floating offshore application are addressed in Clause 14 of ISO 19904-1.

When fatigue is assessed for prior service and an inspection history is available, previous fatigue assessments may be updated based on the outcomes of the inspections campaigns carried out during the occurred service; a reliability based fatigue analysis may be used for the updating of the fatigue response to account for the findings of the inspections, whether defects have arisen or not, see also Clause 14.4 ISO 19904-1.

3 PROVISIONS FOR CONCRETE STRUCTURES

3.1 General

For design and verification of structural parts made of concrete, reinforced concrete or prestressed reinforced concrete, it is recommended to make reference to appropriate international rules, such as EN 1992-1-1 or NS 3473.E latest editions, which are specifically dedicated to offshore applications, for the typical requirements reported for design of concrete structures, as, but not limited to, the following:

- Material requirements for concrete manufacturing (Cement, water, aggregates, additives (if any), reinforcement steel);
- Concrete mix design and testing;
- Design parameters selection for RC and PRC design and relevant testing;
- Strength and ductility requirements;
- Durability requirements and relevant checks;
- Extent of cracking and deformation limit states.

Special attention is to be paid to appropriate reference standards and actual applicability of reported requirements (particularly for concrete manufacturing and durability issues) when reinforced lightweight concrete structures are designed.

SECTION 9 – DESIGN OF FLOATING SUPPORT STRUCTURES

4 SPECIAL PROVISIONS FOR GIVEN TYPE OF FLOATERS

4.1 General

The maximum responses in a semi-sub, as well as in a TLP, are often not governed by the maximum wave height and associated wave period.

In the design of a semi-submersible floating support structure consideration should be given to the most critical response to waves that is the one corresponding to periods giving the maximum split forces between pontoons.

The verification of a semi-submersible floating support structure in the survival conditions relevant to parked turbine (DLCs 6.1 to 6.4 in Table 5-1 of Section 5) should be carried out on the basis of a full spectral load analysis, able to provide appropriate consideration of the following responses in the hull structure:

- Split forces (both transverse and longitudinal or oblique sea, if applicable);
- Torsional effects (in diagonal or near-diagonal seas).

TLPs and their tendons are to be verified against both maximum and minimum water levels. Particular attention is to be paid to the connections between tendons and the hull and between tendons and their anchoring points.

For specific issues relevant to the design of TLPs reference should be made to API RP2T.

It has to be highlighted that one tendon failure may be critical for the whole structure, therefore the floating support structure shall be checked for the loss of one tendon in ALS condition, where minimum tension in at least three corner groups of tendons shall remain non-negative, and steel tendons components and joints are to be verified against fatigue failure with a DFF equal to 10 if not inspectable during the service.

For spars floating support structure the coupling between the yaw and pitch motions shall be considered; heave response is in general not as relevant as pitch and roll, however possible resonant or near resonant heave motion occurrence shall be investigated by model tests.

In case that devices for coping with vortex induced undesired dynamics, e.g. spirals, have been attached to the spars hull, relevant increase in hydrodynamic loading is to be introduced in the analysis.

When passing waves are present, simple Archimedes principles are not applicable for buoyancy calculation on spars floater: for this floater the total buoyancy effect shall be calculated by pressure integration over all wet surfaces of the submerged body and validated, particularly for deep spar system, by model tests.

SECTION 10 – DESIGN OF STATIONKEEPING STRUCTURES

1 STATIONKEEPING CONCEPT SELECTION

1.1 Mooring system selection

The selection of the mooring system configuration is the most important step in the preliminary stages of design of the floating system as it significantly addresses the response to external loads. The choices among different types of mooring systems for a floating support structure, as well as the materials

used for the mooring line, need investigation through comparative analysis. There are three main types of mooring system: a catenary system, a taut leg, and a tension leg type. A preliminary comparison, in terms of general advantages/disadvantages relevant to these three types of mooring system, is reported in the following Table 10-1.

Table 10-1 Alternative mooring configurations

Item	Advantages	Disadvantages
Catenary mooring system	<ul style="list-style-type: none"> • Simple low-cost anchors • Easy installation • Suitable for shallow waters 	<ul style="list-style-type: none"> • Large footprint (long mooring lines) • Ballast or wide buoyancy distribution is needed • Increased floater platform dynamics
Taut leg system	<ul style="list-style-type: none"> • Provides good lateral and vertical restraint • Suitable for shallow to moderate depths 	<ul style="list-style-type: none"> • Expensive anchors • Large footprint in deep water • Each anchor must be able to restrain the entire structure • Difficult deployment

The TLP concept mitigates the first order heave, roll, and pitch motions, although the lateral motion can be considerable and restraint relies on the preload in the tensioned cables. The requirement of rotational rigidity to support the wind turbine is likely to preclude the catenary system; the application to deep water may rule out the use of the taut leg system. Floating Offshore Wind Turbines are generally moored by catenary or tensioned lines, depending on water depth. The first ones are the most common choice for anchoring large floating installations in high sea depths.

In fact, as restoring forces are mainly due to lines' weight, this mooring system requires relatively large weights in intermediate waters, respect to tensioned mooring lines, whose restoring forces are due to the axial stiffness of lines.

1.2 Anchoring System Selection

Several types of anchors can be used in conjunction with one or more mooring systems:

Table 10-2 Alternative anchoring configurations

item	advantadges	disadvantages
Gravity anchor	<ul style="list-style-type: none"> • Suitable for any soil condition provided bottom is flat • No surface preparation required 	<ul style="list-style-type: none"> • Large quantity of material and ballasts required, especially with tension leg mooring
Suction Piles	<ul style="list-style-type: none"> • Tested in offshore industry 	<ul style="list-style-type: none"> • Suitable soil conditions only • Specialized equipment needed
Driven Piles	<ul style="list-style-type: none"> • Tested in offshore industry • Can resist considerable lateral tension 	<ul style="list-style-type: none"> • Suitable soil conditions only • Specialized equipment needed
Plate anchors	<ul style="list-style-type: none"> • Suitable with catenary system 	<ul style="list-style-type: none"> • Suitable soil conditions only • Not suitable for TLP-type uplift requirements
Gravity anchor with suction embedment or skirt plates	<ul style="list-style-type: none"> • Reduced lateral movement ("creep") 	

The following Table 10-3 is reported as a general guide for matching the considered types of mooring and anchoring. As a basic rule, in the case of catenary mooring, all kinds of anchors can be applied. For taut moorings, inclined or vertical, the vertical forces should be considered with extreme care, because it is usually the critical parameter.

Note

The Table is reported for general addressing, not including all possible anchor types but a few traditional anchor types while other types (e.g. drilled or screwed piles) as well as newer technologies (micropiles) may be considered as possibly resulting as an appropriate choice (e.g. micro-piles, drilled pile anchors, etc.)

SECTION 10 – DESIGN OF STATIONKEEPING STRUCTURES

Table 10-3 mooring and anchoring solutions

Type	Ancor	Gravity anchors	Drag anchors	Driven Piles	Suction Piles	Plate anchors	Screw piles
Catenary		Applicable but not the best choice	Recommended (1)	Applicable but not the best choice	Applicable but not the best choice	Applicable but not the best choice	Applicable but not the best choice
Taut Leg		Applicable but not the best choice	Not recommended (2)	Recommended (3)	Recommended (3)	Recommended (3)	Applicable but not the best choice
Vertical		Applicable but not the best choice	Not recommended (2)	Applicable but not the best choice	Applicable but not the best choice	Recommended	Applicable but not the best choice
(1) Among all the options to moor a structure, and if a catenary system is selected, the best option is a traditional anchor due to its low cost (2) In the case of taut systems, it is necessary to have anchors that withstand vertical loads, this is the reason why traditional anchors are not applied (3) When a taut system is applied, the best choices are piles, suction piles and plate anchors.							

2 MOORING SYSTEM

2.1 Design principles

Mooring analysis shall be performed to assess the reliability of the mooring design in relation to strength and fatigue.

The maximum design condition is defined as that combination of wind, waves, and current for which the mooring system is designed.

Mooring systems shall be designed for the combination of wind, wave, and current conditions causing the extreme mooring loads in the design environment, for each mooring line.

In general a 50-year design environment is used and the following cases are analysed:

- 50-year wave with associated wind and current;
- 50-year wind with associated wave and current;
- 50-year current with associated wave and wind.

The most severe directional combination of wind, wave, and current are to be selected, consistent with the site's environmental conditions.

Depending on the type of floating structure and mooring system, the global response to environmental loading can be dominated by low frequency or wave frequency motions (see Section 8).

Therefore, most severe mooring loads can occur for seastates that differ from the specified return period maximum condition.

For the design assessment, the tension in a mooring line can be considered as the sum of two components: the mean tension and the dynamic tension.

The mean tension is defined as the mean part of the 50-years value of the line tension and is caused by pretension and mean environmental loads from static wind, current and wave drift.

The dynamic tension is defined as the dynamic part of the 50-year value of the line tension and is caused by oscillatory low-frequency and wave-frequency effects.

[Guidelines](#)

The governing case for ultimate strength mooring design is normally reported in 50-year environmental conditions where the turbine is in parked condition, but conditions with maximum turbine thrust are to be verified as well.

In the mooring line design load evaluation, the following effects are to be taken into account and sensitivity analysis are to be performed:

- installation tolerances;
- chain length/pretension tolerances;
- chain corrosion;
- marine growth;
- water depth (tide/bathymetry) variation;
- waves period variation;
- seabed friction variation.

Modal analysis shall be performed on all lines.

Vortex induced vibrations and motions shall be accounted for both strength and fatigue assessment.

2.2 Environmental forces and floating structure motions

Environmental exciting forces can be categorized according to the following distinct frequency bands:

- steady loads such as wind, current, and drift mean wave forces. These forces are constant in magnitude and direction for the duration of interest;
- low frequency cyclic loads (such as slow varying drift forces or long-period variations in wind strength);
- wave frequency cyclic loads with typical periods ranging from 5 to 30 seconds. Wave frequency cyclic loads result in wave frequency motions;
- high frequency actions, typically below 5 seconds. Surge sway and yaw natural periods usually are within the low frequency bands, while heave, roll and pitch natural periods can fall in the wave frequency or high frequency bands (TLP structures usually have resonance periods between 2 and 5 seconds).

SECTION 10 – DESIGN OF STATIONKEEPING STRUCTURES

A preliminary investigation of the natural periods of all six degrees of freedom of the moored structure shall be performed in order to assess in which frequency band they occur and the corresponding wave energy associated.

The mooring system and support structure should be designed so that the natural periods of the whole system occur in frequency ranges where the exciting forces energy is as low as possible.

2.3 Global dynamic behaviour

2.3.1 General

The forces acting on the system are usually a function of both time and floater position. In the attempt to separate the forces into separate terms to allow a simple solution, a number of assumptions and linearizations are usually made.

To represent the system behaviour two types of analyses are available (see also Section 8):

- uncoupled;
- coupled.

2.3.2 Uncoupled Analysis

The model can be limited to a rigid structure and exclude mooring displacements, based on the assumption of no interaction between mooring and the floating structure dynamic response.

When using this approach, the validity of this assumption shall be demonstrated.

Decoupled analysis is applied to compute the system response using a two-step approach:

- Rigid body floater motions are computed in the first step and include static low frequency (LF) and wave frequency (WF) environmental loading. The mooring system is represented by the static restoring force characteristics.
- Dynamic slender structure analysis is considered in the second step by using the floater motions calculated in the first step as forced boundary displacements. Wave and current loading on the mooring system is also included.

2.3.3 Coupled Analysis

In this type of calculation the model couples the dynamics of floater and mooring and coupling effects can be taken directly into account. This approach gives dynamic equilibrium between the forces acting on the floater and the slender structure response at every time instant.

2.4 Simulation of floating structures dynamics

2.4.1 General

Simulation of floating structure dynamics can be performed using a frequency domain or time domain approach or a combination of the two. All three approaches include certain techniques of

approximation and therefore may not yield consistent results.

All the three approaches have limitations (see Section 8). The approach selected for the mooring design should be verified by model test data, full-scale test data, or a different analytical approach.

2.4.2 Frequency domain analysis

Frequency domain analysis refers to a solution of the equation of motion by methods of harmonic analysis of methods of Laplace and Fourier transforms.

This technique requires linear equations of motion. Nonlinear effects such as viscous damping, drag loads, time varying forces (such as restoring force due to the variation of the immersed structure geometry with surface elevation) are approximated through a linearization process. In some cases, such linearization can lead to excessively simplified models and erroneous results.

2.4.3 Time domain approach

Time domain analysis allows taking into account changing boundary conditions and nonlinear forcing and stiffness functions. The simulations must be carried out for a length of time sufficient to achieve stationary statistics. The main disadvantage is the extensive computational time required.

In this approach the forcing functions include the mean, low frequency, and wave frequency forces due to wave, wind and current.

Time histories of all system parameters (structure displacements, mooring line tensions, anchor loads, etc.) are available from the simulation, and the resulting time histories are then processed statistically to yield expected extreme values.

2.4.4 Combined time and frequency domain approach

To reduce the complexity and computational effort associated with the full-time domain simulation, a combined time and frequency domain approach is often undertaken. Time and frequency domain solutions for mean loads, wave and low frequency motions can be combined in different ways. In a typical approach, the mean and low frequency responses (floater displacements, mooring line tensions, etc.) are simulated in time domain while the wave frequency responses are solved separately in frequency domain.

The frequency domain solution for wave frequency responses is processed to yield either statistical peak values or time histories, which are then superimposed on the mean and low frequency responses.

When using this approach, it shall be clearly demonstrated that first order (wave frequency) motions of the floater are not affected by the mooring system.

SECTION 10 – DESIGN OF STATIONKEEPING STRUCTURES

2.5 Simulation of mooring line response

Mooring line response is to be analysed through a fully nonlinear time domain dynamic analysis as this kind of analysis accounts for:

- time varying effects due to mass, damping, and fluid acceleration;
- nonlinear effects such as:
 - nonlinear stretching behaviour of the line;
 - changes in geometry. The geometric nonlinearity is associated with large changes in shape of the mooring line;
 - fluid loading. The Morison equation is most frequently used to represent fluid loading effects on mooring lines;
 - bottom effects. In many mooring designs, a considerable portion of the line is in contact with the seafloor. The interaction between the line and the seafloor is usually considered to be a frictional process and is therefore nonlinear. In addition, the length of grounded line constantly changes, causing an interaction between this nonlinearity and the geometric nonlinearity.

The time-varying fairlead motions are calculated from the floater's surge, sway, heave, pitch, roll, and yaw motions.

Finite element dynamic models shall be used to predict mooring line responses to the fairlead motions, hydrodynamic loading and seabed interaction.

2.6 Strength Analysis

2.6.1 General

Strength analysis shall be performed to ensure that line tensions are within allowable values when the system is subject to extreme environmental loading.

Sufficient clearance should be ensured in order to avoid interference with other structures.

A short-term analysis of the most critical cases is to be considered for the computation of the mooring loads.

The design load cases to be considered for the stationkeeping system strength assessment are those of Table 5-1 of Section 5, as well additional load cases, as applicable, according to [4.2.4] of Section 5.

The stationkeeping system is also to be designed against the SLCs indicated in Table 5-3 of Section 5.

The characteristic value of mooring load to be considered for the strength assessment is the maximum expected value for 3 hours return period in the most critical situation; a 3 parameter Weibull distribution may be used in order to fit the distribution of the "maxima between two mean-up-zero-crossing". The 3 parameter Weibull cumulative distribution function is represented by the following formula:

$$W(x) = 1 - \exp \left[- \left(\frac{x - m}{q} \right)^p \right]$$

where the parameters m, p and q are depending on specific project conditions. Several 3-hour simulations with different random seeds or an equivalent long simulation should be run in order to provide a good statistical evaluation and confidence.

2.6.2 Mooring strength analysis conditions

Mooring analysis is to be carried out for the following conditions.

Intact condition, that is the condition in which all mooring lines are intact;

Damaged condition, that is the condition in which the floater oscillates around a new mean position after one mooring line breakage;

Transient condition, that is the condition in which the floater is subjected to transient motions after one mooring line breakage.

2.6.3 Strength analysis based on time domain simulations

This approach requires a time domain mooring analysis computer program, which solves the general equations of motion for the combined mean, low, and wave frequency responses of the floater and mooring lines.

A significant advantage of this approach is that low frequency damping from the floater and mooring lines are internally generated in the simulation. Also the coupling between the floater and the mooring system can be fully accounted for.

Statistical fitting techniques and repetition of the simulation are required to establish reasonable confidence in the predicted extreme response (see [2.6.1]).

2.6.4 Strength analysis based on combined time domain and frequency simulations

In this approach wave frequency motions are calculated in the frequency domain from the floater's motion RAOs and the wave spectra, while mean and low frequency motions are calculated solving the equations of motion in the time domain.

Wave frequency motions can be combined with the low frequency motions in two ways:

- frequency domain solution of wave frequency motions is transformed to a time history, which is added to the mean and low frequency floater displacement to arrive at the combined floater displacement;
- mean and low frequency motions time histories are statistically analyzed to determine the peak values, which are then combined with the peak values of wave frequency motions to arrive at maximum offset.

2.6.5 Strength design criteria for steel mooring lines and tendons

The maximum tension of a steel mooring line or a tendon shall not exceed relevant allowable tension

SECTION 10 – DESIGN OF STATIONKEEPING STRUCTURES

limits, which are normally expressed as a percentage of the minimum breaking strength (MBS) of the mooring component. Specifically, the allowable tension limits may be assumed as equal to the given MBS value divided by the applicable safety factor SF reported in Table 10-4, provided that all the partial safety factors for load effects from all load categories (DLCs and SLCs) are

set equal to 1.0 (since in this case a WSD is being used). SFs are reported in Table 10-4 for the two sets of loading conditions applicable to stationkeeping system (DLCs and SLCs) and for the design condition (intact,damaged or transient) of the stationkeeping system, which is to be differently considered whenever redundant or not.

Table 10-4 – Safety factors for allowable tension in mooring lines or tendons

Loading case	Stationkeeping System	Mooring strength analysis condition (see 6.2)	Safety factor
Design (DLCs table 6x)	Redundant	Intact	1.67
		Damaged	1.25
		Transient	1.05
	Non.Redundant	Intact	2.0
Survival (SLCs table 6y)	Redundant or Non-Redundant	Intact	1.05

These criteria are intended for moorings which are properly maintained and inspected. For recommendations relevant to applicable allowances for corrosion and abrasion of steel mooring lines reference can be made to the API RP2SK Standard. Additional strength design requirements for tendons made up of steel pipes are to be in accordance with API RP2T. In particular tendons are to be verified against slack (i.e. shall remain in tension) for any of the design condition relevant to ULS (DLCs corresponding to U in Table 5-1).

2.7 Fatigue Analysis

2.7.1 General

Fatigue life estimates are made by comparing the long-term cyclic loading in a mooring line component with the resistance of that component to fatigue damage. For mooring systems, a T-N approach is to be used, which gives the number of cycles to failure for a specific mooring component as a function of constant normalized tension range, based on the results of experiments.

Fatigue analysis shall take into account:

- tension-tension fatigue (T-T);
- bending-tension fatigue (B-T);
- free bending fatigue.

2.7.2 Fatigue analysis formulation

The Miner’s Rule is used to calculate the annual cumulative fatigue damage ratio D:

$$D = \sum \frac{n_i}{N_i}$$

where:

n_i : number of cycles per year within the tension range interval i.

N_i : number of cycles to failure at normalized tension range i as given by the appropriate T-N curve.

T-N curves for various mooring components should be based on fatigue test data for these components and a regression analysis.

2.7.3 Fatigue analysis procedure

The fatigue assessment shall be carried out according to the procedure and methods outlined in Sec 9, [2.5] by specifically considering:

- The stationkeeping system is to be considered intact in global performance analysis for the fatigue design load cases.
- The long-term environmental events may be represented by a number M of discrete environmental states. Each environmental state consists of a reference direction and a reference seastate characterized by significant wave height, peak spectral period (or equivalent), spectral shape, current and wind velocities and directions.
- A time domain approach is usually adopted for the analysis of each environmental state.
- Because full time domain simulations can require a big computational effort the time required to perform all the M simulations can be huge. Provided that the yaw motion (i.e. variation from the mean) of the structure is negligible and that the mooring system response to low frequency (LF) and wave frequency (WF) forces can be considered uncoupled, mean+LF and WF contributions can be addressed separately and then added to give the total damage.
 - Fatigue damage due to mean and low frequency contributions is to be calculated through a time domain simulation for all M cases, associating to each case the specific probability of occurrence.
 - Maximum expected values are to be calculated by the Weibull distribution assumption (see [2.6.1]).

SECTION 10 – DESIGN OF STATIONKEEPING STRUCTURES

- For each case the mean heading is stored so that the wave heading (wave direction with respect to the structure) probability of occurrence can be calculated.
- Fatigue damage due to wave frequency contribution is calculated performing time domain or frequency domain simulations for all Hs-Tp couples of the scatter diagram and for the selected number of wave headings, “fixing” the mooring system yaw angle and associating to each heading-Hs-Tp case the respective probability of occurrence.

Mooring line diameter reduction due to corrosion and wear shall be taken into account for fatigue analysis.

2.7.4 Fatigue design criteria for steel mooring lines and tendons

The calculated fatigue life of the mooring line or tendon is not to be less than the design service life of the mooring system times the Design Fatigue Factor DFF reported in Table 10-5 by considering that:

- DFFs reported in Table 10-5 are assumed on the basis that the steel mooring lines or tendons are not accessible for inspection and repair along with their service life. In case that a dedicated inspection plan is provided and effective for the appropriate management of the specific fatigue issue (e.g. by scheduling close Non Destructive Examination for fatigue prone components of the mooring system) the DFFs for Redundant and Non-Redundant system may be decreased up to minimum values of 2 and 3 respectively;
- The design service life of a given mooring component may be reported as being lower than the one of the floating support structure, provided that a plan including appropriate substitution of the given mooring component is effective and managed during the service.

Minimum set of DLCs for fatigue assessment is specified in table 5-1 of Section 5 where F is reported in last column.

Additional requirements of [4.2.4] of Section 5 are to be considered when appropriate, particularly with regards to VIV fatigue.

For the tendon, the unfactored damage accumulated during a single extreme environmental event with a return period of 50 years is to be evaluated as additional verification, and it is to be less or equal to 0.02, independently of fatigue damage accumulation due to long term environmental loads.

Table 10-5 – Design Fatigue Factors for allowable tension in mooring lines or tendons

Stationkeeping System	DFF
Redundant	5
Non-Redundant	10

2.8 Synthetic fiber rope mooring

In case that components of the stationkeeping system are made of, or incorporating, synthetic fibre ropes, relevant requirements, as applicable, with particular reference to:

- Fiber rope mooring analysis;
- Fatigue analysis;
- Creep analysis;
- Design criteria;
- Model testing,

can be found in Clause 14 of ISO 19901 Part 7, Stationkeeping systems for floating offshore structures and mobile offshore units.

Moreover, since synthetic fibre rope mooring technology is rapidly evolving, a specific qualification process for novel fibre ropes intended to use is to be performed in accordance to RINA technology qualification procedure (ref. Sec 1, [3]), or other recognized qualification procedure, covering, but not limited to, the following aspects:

- Rope strength;
- Tension-elongation properties;
- Fatigue resistance;
- Rope protection;
- Torque properties, as applicable.

3 ANCHORING SYSTEM

3.1 General

This item is relevant to the requirements for geotechnical foundation design of the anchoring system that transfer the loads from mooring lines or tendon of the stationkeeping system (designed in accordance with [2]) to the seabed soil.

For overall considerations relevant to the foundation design of floating offshore structures reference can be made to Subclauses 5.1, 5.2 and 5.3 of ISO 19901-4.

3.2 Geotechnical investigation

General requirements for shallow geophysical investigation and identification of hazards are provided in ISO 19901-4, Subclause 6.2.

The design of the anchoring system is to be based on information taken from the actual offshore location of the wind farm, considering an investigation area of sufficient extent to cover the possible final positioning of the installations, including tolerances due to uncertainties relevant to final marine operation.

The investigation on location is to be sufficiently extensive to include all the soil layers and rock deposits which may influence the behaviour of the anchoring system.

The investigation is to supply data for the classification and description of deposits and parameters to be used in the check calculations for the involved soil layers.

The investigation may be carried out by one or a combination of the following principal methods:

SECTION 10 – DESIGN OF STATIONKEEPING STRUCTURES

- geophysical methods;
- in situ tests;
- borings with sampling for laboratory tests.

The results of investigation on location are to be submitted to RINA for consideration and should include:

- information on when the investigation was carried out and by whom;
- comprehensive description of equipment and procedures used for in situ and laboratory investigation;
- results of the above investigation;
- critical examination of possible sources of errors and limitations in the applicability of the results.

As applicable for the wind farm installation site, a sea bed investigation is to be carried out for the purpose of revealing the presence of natural obstacles (rocks, deposits, etc.) or other types of obstructions (anchors, wrecks, etc.), the soil waviness height and the possible occurrence of sand dune displacements or sea bed alterations.

3.3 Design principles

3.3.1 General

The design of anchoring system is aimed at preventing failure of the foundation bearing capacity and loss of mooring for the components of the stationkeeping system of the floating wind turbine installation.

The possibility of excessive deformations is to be independently evaluated.

Any type of analysis shall take into account risk of scour (see 3.3.8).

The calculations are to cover both the installation and operation phases, as applicable.

3.3.2 Characteristic properties of soil

The characteristic properties of each layer of soil are to be carefully evaluated on the basis of the results of in situ and laboratory tests (see 3.2), taking into account the stress conditions in the sample during the tests and of the actual stress conditions in the layer considered.

3.3.3 Effects of pulsating loads

Where deemed necessary, the influence of load fluctuations on the soil properties is to be evaluated.

The effects of wave induced forces are to be considered for the following conditions:

- a design storm during the installation phase and the consolidation period;
- the 50-year storm;
- the cumulative effect of several storms, including the 50-year storm.

Realistic assumptions are to be made regarding the duration and intensity of such storms.

In the case of units installed in seismically active geographical areas, the possible deterioration of soil

properties because of seismic actions is to be taken into consideration (see also [3.3.7]). Such deterioration generally results in a reduction of shear strength of soil, which is to be considered in the design.

3.3.4 Stability

The stability should be analysed for shallow foundations ensuring equilibrium between design actions and design resistance. The principles are described in Subclauses 7.1 and 7.2 of ISO 19901-4, considering that main requirements for stability analysis are the following:

- an effective stress stability analysis based on effective strength parameters of the soil and realistic estimates of the pore water pressures in the soil. Such method requires laboratory shear tests with pore pressure measurements;
- total stress stability analysis based on total shear strength of the soil evaluated on representative soil samples which are to be subjected, as far as practicable, to the same loading conditions as corresponding elements in the soil.

3.3.5 Settlements and displacements

In the evaluation of settlements and displacements, the following aspects are generally to be considered:

- initial and secondary settlements;
- differential settlements;
- permanent horizontal displacements;
- dynamic motions due to load fluctuations.

The evaluation of settlements may be essential for the design of foundation piles.

The tilt of the floating support structure consequent to differential settlements of the stationkeeping system, due to variations in the soil characteristics and/or preferential direction of application of external loads, is not to exceed the tilt which can be allowed for the operability of the wind turbine.

Settlements and displacements topics for shallow foundations are reported in Subclause 7.8 of ISO 19901-4.

3.3.6 Slope stability

The analysis of slope stability, if applicable, is to consider the natural slopes, those due to the installation or the presence of the anchoring system, the possible future variations of existing slopes during the design life and the effects of wave loads on the sea bed.

The slope stability is to be carefully evaluated in the presence of layers of soft clays and loose deposits of silt or sands as well as in seismically active geographic areas.

3.3.7 Hydraulic stability

In the case of installations whose foundations are on soils subject to erosion and softening (reduction in the

SECTION 10 – DESIGN OF STATIONKEEPING STRUCTURES

modulus of elasticity due to fluctuating loads), if relevant for the actual anchoring system, the following aspects are to be analysed:

- reduction of soil bearing capacity due to hydraulic gradients and seepage forces;
- formation of piping channels and consequent erosion in the soil;
- local surface erosion in areas under the foundation due to hydraulic pressure variations resulting from environmental loads.

3.3.8 Scour

The effect of scour around the anchor foundation is to be taken into account, particularly for anchors with exposed parts above the seabed, such as pile or suction anchors, unless it can be proved that the foundation soil is not subject to scour for the expected range of water particle velocities.

To prevent the effects of scour, one of the following measures is to be taken:

- materials placed around the interested area as early as possible after the installation;
- foundation system designed considering all materials which are not resistant to scour as having been removed;
- direct inspection of sea bed close to the foundations and provision of suitable means to quickly stop the development of any scour detected.

Materials placed on the sea bed to prevent scour are to have adequate weight and dimensions, such as the ones that are not subject to removal by current action and the ones that prevent soil erosion without impairing the draining of overpressure caused on the layers by the loads imposed.

3.4 Drag Anchors

Actual drag anchor holding power can be reliably determined only after anchor deployment and load testing, since it depends on the specific type of anchor and relevant characteristics, such as penetration and openings of the flukes, depth of burial, final dragging soil behaviour and other uncertain parameters that affect the Ultimate Holding Capacity parameter, UHC, which is to be referred to in the design, for comparison with the acting anchor load.

An estimation of UHC for anchor design shall be based on the performance data for a given anchor type – among a wide variation of anchor characteristics - and site-specific soil properties, provided the required value that is to be determined based on maximum design mooring line or tendon loads T_d derived from the dynamic analyses described in [2.6], for the applicable DLCs and SLCs recommended in Sec 5.

The maximum design anchor load F_d may be then calculated by the following relationship:

$$F_d = (T_d - F_f - W_{su} * d_w) * \gamma_d$$

where:

- F_f is the holding power on the mooring line on the seabed, which can be calculated as:

$$F_f = f * L_s * W_{su}$$

where L_s is the length of the mooring line on the seafloor and f is the coefficient of friction of the mooring line on the seafloor.

Appropriate selection of f is to be documented, based on experience, proven data and/or applicable recommended practice. For instance, the values reported by API RP2SK may be adopted (i.e., for a chain, 1.0 and 0.7, for static and sliding condition respectively, whereas corresponding values of f for a wire rope are 0.6 and 0.25 respectively).

- W_{su} [N/m] is the submerged unit weight of the mooring line;
- d_w [m] is the water depth at final deployment site;
- γ_d is the Factor of safety for the anchor holding capacity; reference values of γ_d are reported in Table 10-6.

Table 10-6 –Factor of safety γ_d for Drag Anchors holding capacity

Loading cases	Stationkeeping characteristics	Design condition of the Stationkeeping System	γ_d
DLCs	Redundant	Intact	1.5
		Damaged (one line broken)	1.0
	Non-redundant	Intact	1.8
SLCs	Any	Intact	1.05

The above reported formulation and numbers are valid provided that

- The total mooring line length L_t for a catenary mooring system with drag anchors is as long as not to provide angle between the mooring line and the seabed in any design condition;
- The length of the mooring line on the seafloor L_s is not to exceed 20 percent of L_t .

3.5 Vertically Loaded Drag Anchors

The holding capacity design documentation of vertical loaded drag anchors (VLAs), possibly used in a taut line mooring system, with an angle of approximately 35 to 45 degrees between the sea floor and the mooring line, is to be submitted to RINA for review, based on the adopted VLA geotechnical and structural design properties, by including evaluation of the ultimate holding capacity and anchors burial depth beneath the sea floor, as well as fatigue assessment of the anchor

SECTION 10 – DESIGN OF STATIONKEEPING STRUCTURES

and the connectors joining the anchor to the mooring line.

Reference values of g_d applicable for VLAs are reported in the following table 10-7:

Table 10-7 - Factor of safety γ_d for VLAs holding capacity

Loading cases	Stationkeeping characteristics	Design condition of the Stationkeeping System	g_d
DLCs	Redundant	Intact	2.0
		Damaged (one line broken)	1.5
	Non-redundant	Intact	2.4
SLCs	Any	Intact	1.05

3.6 Gravity anchors

When gravity anchors are used for foundation design of the stationkeeping system, relevant geotechnical and structural design, based on recognized international standards and applicable rules, is to be submitted to RINA for review.

Consideration should be given to the following aspects:

- The capacity against uplift of a gravity anchor is to be appropriately evaluated (in principle it has not to be greater than the submerged mass of the anchor);
- For gravity anchors constructed with steel skirts aimed at penetrating in the seabed soil, the contribution to the bearing capacity from soil frictional resistance along the skirts vertical surfaces may be included, but only as additional capacity for withstanding the dynamic component of the acting load, and with appropriately conservative assumption regarding the required friction mechanism properties;
- The risk of scour is always to be considered for gravity anchors, in accordance with what reported in [3.3.8].

3.7 Conventional Piles

Conventional piles anchors may be used to provide both uplift and lateral capacity required by vertical and horizontal components of the mooring line tension.

The analysis and design of such piles can be performed in accordance to the applicable requirements used in the recommended practice for piles design of foundation of fixed offshore units, as reported in item [4].

3.8 Suction Piles

Suction piles are vertical cylindrical section piles, with larger diameter and shorter length with respect to conventional piles, with open or closed top, installed by self-weight penetration and penetrated to the targets

depth by the application of under pressure, suction, by pumping out the water within the pile closed compartments.

They are normally used in clays where it is easy to trigger the suction within the pile due to low permeability of the soil.

The typical configuration consist of a stiffened cylindrical shell with open or closed top.

Final anchor resistance is a function of soil properties, mainly the undrained shear strength, and is composed by a horizontal and a vertical components, whose coupling, under combined horizontal and vertical loads, is to be carefully evaluated since it has been shown that the coupling may reduce the vertical and horizontal resistance at failure, and the resulting final resistance is lower than the mere vectorial sum of the uncoupled maximum vertical and horizontal resistance.

When suction piles are used as foundation of the stationkeeping system of the floating wind turbine installation, relevant geotechnical holding capacity evaluation and structural design – carried out in accordance with appropriate criteria from recognized international standards or codes - are to be submitted to RINA for review, to demonstrate their adequacy to withstand in service and installation loads, by taking into account that the failure mechanism in the clay around the pile may be different than those applicable for long slender conventional piles and may depend, besides the soil properties, on different factors such as the load inclination and relevant point of application (the padeye for the mooring line connection can be at the top or at an intermediate level, depending on the specific application), the ratio among depth and diameter of the pile and whether its top section is open or closed.

Fatigue and installation analyses of the suction piles are also to be submitted to RINA for review.

4 APPENDIX A10 – OFFSHORE PILE FOUNDATION DESIGN

4.1 General requirements

In the offshore practice the type of pile foundation differs since the installation method:

- driven piles;
- drilled and grouted piles;
- belled piles;
- vibro-driven piles;
- suction piles.

Detailed description of pile foundations is given in Subclause 17.2 of ISO 19902:2007.

General requirements are reported in Subclause 17.3 of the ISO 19902:2007. The design strength of coupled structure/soil design model are to be in accordance with the criteria defined below or according to an applicable international standard to be adopted in accordance with RINA.

SECTION 10 – DESIGN OF STATIONKEEPING STRUCTURES

4.2 Analyses to be performed

4.2.1 General

The foundation pile is to be analysed on the basis of acting loads transmitted by the stationkeeping system relevant to the applicable loading conditions.

4.3 Pile design criteria

In the design of piles for foundations it is necessary to take account of the method used for their installation.

Where the transfer of loads from one pile to another or from a pile to the foundation soil is achieved by grouting, the surfaces are to be free from rust scales or other imperfections which may reduce the capacity of load transfer.

The design pile penetration is to be sufficient to provide adequate capacity to withstand the design compressive and tensile loads.

The foundation capacity is to be verified by the following two strength assessments, depending on the steps of the load transfer path generated from the structure to the soil.

a) Pile strength

The pile strength shall be carried out according to the applicable Design Loading Conditions (DLCs).

Internal pile forces to be checked are the ones due to the design actions according to the applicable DLCs using a coupled structure/soil non-linear foundation model. Take care to consider the column buckling effect on the pile in which case the lateral restrains of the soil is inadequate.

b) Pile axial resistance

The axial pile capacity is to be defined, in accordance with Equations (17.3-1) and (17.3-2) of ISO 19902:2007, as:

$$Q_{d,e} = \frac{Q_r}{\gamma_{R,Pe}}$$

$$Q_{d,p} = \frac{Q_r}{\gamma_{R,Pp}}$$

where:

- Q_{d,e} : extreme design axial pile capacity;
- Q_{d,p} : design axial pile capacity for permanent and variable actions or operating situations;
- Q_r : representative value of the axial pile capacity as determined in 4.4;
- γ_{R,Pe} : pile partial resistance factor for extreme conditions (γ_{R,Pe} = 1.25);
- γ_{R,Pp} : pile partial resistance factor for permanent and variable actions or operating situations (γ_{R,Pp} = 1.50).

The axial pile capacity shall satisfy the following conditions, as per Equations (17.3-1) and (17.3-2) of ISO 19902:2007:

$$P_{d,e} \leq Q_{d,e}$$

$$P_{d,p} \leq Q_{d,p}$$

Where the subscript 'e' means the design actions for the extreme conditions and the subscript 'p' represents the design actions for the permanent and variable actions or operating situations according to the applicable DLCs.

The design bearing capacity of piles is to be limited to penetrations which have proved to be consistently obtained by experience; before installation, alternative solutions are also to be foreseen to be applied where design penetration cannot be obtained.

4.4 Pile capacity for axial compression

4.4.1 Ultimate bearing capacity

The characteristic ultimate bearing capacity of pile Q, in kN, is given by the equation:

$$Q = Q_s + Q_p$$

where:

Q_s : characteristic total skin friction resistance of pile, in kN, due to external and/or internal friction contribution. Equal to:

$$\sum f_i \cdot A'_{si}$$

Q_p : characteristic total end bearing capacity of pile, in kN:

$$q A_p$$

f_i : unit skin friction capacity in the i layer, in kN/m²;

A_{si} : external side surface area of pile in the i layer, in m²;

q : unit end bearing capacity of pile, in kN/m²;

A_p : gross end area of pile or annulus area of pile (it depends on the presence or not of the plug), in m²;

D_e : pile end external diameter, in m;

D_i : pile end internal diameter, in m;

In determining the ultimate bearing capacity of piles, consideration is to be given, when appropriate, to the weight of pile-soil plug system and to hydrostatic uplift.

The contribution of the total end bearing capacity (Q_p) and of the internal friction (Q's) shall not be considered both together.

If the pile is driven up to the target penetration depth, the axial force shall not exceed the sum of the external friction contribution (Q_s) and the internal friction contribution (Q's) and the total end bearing capacity acting only on the pile wall annulus, or the sum of the external friction contribution (Q_s) and the end bearing

SECTION 10 – DESIGN OF STATIONKEEPING STRUCTURES

capacity (Q_p) acting on the total end bearing area, whichever is lesser.

For open-ended pipe piles plugged, the total end bearing capacity, Q_p , shall not exceed the sum of the end bearing capacity of the internal plug and the end bearing on the pile wall annulus.

In computing the design actions in compression on the pile, the weight of the pile is to be considered.

Where a pilot hole is drilled, its end bearing area is to be discounted in computing the area A_p .

As a rule, for pile-bell systems the skin friction resistance of a portion of pile above the bell-shaped area having length of 3 pile diameters is to be neglected. If the pile-bell system is driven with a pilot hole, the area of the hole should also be discounted in computing the total bearing area of the bell.

If the pile is laterally loaded by cyclic loads and deformations imposed on the soil are rather high (higher than the quantity y_c defined in §4.6.2), the friction resistance relevant to those layers of soil affected by such deformations is to be reduced or annulled.

4.4.2 Skin friction and end bearing capacity of piles in clay soils (cohesive soil)

a) For piles driven through clay, the unit skin friction capacity f is generally not to exceed the values given in Table 5.1 as a function of the undrained shear strength of the clay soil, c .

For piles driven in undersized drilled holes or jetted (drilled by jetting of fluid under pressure) holes and for drilled and grouted piles in normally consolidated clay soils, f values are to be determined by reliable methods based on the evaluation of soil disturbance resulting from installation.

In any case, the values given in Table 5.1 are not to be exceeded.

For drilled and grouted piles in over-consolidated clay soils, f values may exceed those given in Table 4.1.

In this case, careful consideration is to be given to the strength of the soil-grout and grout-pile skin interfaces also in relation to the amount and quality of drilling mud used.

b) The unit end bearing capacity of piles in clay soils q , in kN/m^2 , may be determined, in general, by the equation:

$$q = 9c$$

Special consideration is to be given where the value of the shear strength of the soil in layers under the end of piles changes in an uneven way.

Table 4.1 – Unit skin friction capacity f as a function of the undrained shear strength of the clay soil c

c (kN/m^2)	f (kN/m^2)
$c \leq 24$	$f = c$
$24 < c < 72$	$f = \left(1, 25 - \frac{c}{96}\right) \cdot c$
$c \geq 72$	$f = 0,5 c$

The pile capacities computed above represent the long-term capacities. The axial capacity immediately after installation of piles is usually lower. The set-up of piles passes through the initial change of undisturbed soil condition due to the driven phase which generates pore overpressures. After that pure overpressures drift to dissipate and the soil drift is dependent on the development of pore pressures during installation phases and its consequent dissipation. The shortly application of design actions are important design consideration to be done in light of the lower axial capacity of pile immediately after installation.

4.4.3 Skin friction and end bearing capacity of piles in sandy and silty soils (cohesionless soil)

The unit skin friction capacity f , in kN/m^2 , of piles driven in sandy and silty soils, except carbonate sands and gravels, may be determined by the following equation:

$$f = K \cdot p_o \cdot tg\delta$$

where:

K : coefficient of lateral soil pressure (ratio of horizontal to vertical normal effective stress);

p_o : effective overburden pressure of soil around pile at the depth in question, in kN/m^2 ;

δ : friction angle between the soil and pile wall, in degrees.

K coefficient varies between 0,5 and 1 with the increase of the grade of sand density (the growth is not linear). In particular for open-ended piles driven unplugged, it is appropriate to assume K as 0.8 for both tension and compression loadings. When piles are plugged or close-ended the K coefficients may be assumed as 1.0. The values of friction angle δ depend on the angle of internal friction of soil ϕ in degrees and if other data are not available Table 4.2 may be used.

For close-ended or fully plugged open-ended piles values of " $K tg\delta$ " may be increased by 25%.

For long piles f may not indefinitely increase linearly with the overburden pressure p_o . In such case it is appropriate to limit f to the limiting skin friction values f_{lim} given in Table 4.2, dependent on the angle of internal friction of soil ϕ in degrees.

SECTION 10 – DESIGN OF STATIONKEEPING STRUCTURES

f values from the above equation may be adopted even for open-ended piles driven unplugged in drilled and grouted holes.

For piles driven in undersized drilled holes or jetted holes, f values are to be determined by reliable methods based on the evaluation of soil disturbance resulting from installation and are not to exceed those for driven piles.

The unit end bearing capacity of piles q, in kN/m², in sand and silt soils, except carbonate sands and gravels, may be determined by the following equation:

$$q = p_o N_q$$

where:

N_q : bearing capacity factor;

p_o : effective overburden pressure of soil around pile at the depth in question, in kN/m².

N_q values depend on the angle of internal friction of soil φ in degrees, in accordance with data given in Table 4.2.

For deep foundations q values may be lower than those given above.

For layered soils, N_q may be limited to values lower than those given in Table 4.2 and are to be determined on the basis of considerations regarding the local soil conditions.

Table 4.2 – Foundation characteristics as a function of soil type

SOIL TYPE	Φ (°)	δ (°)	N _q	f _{lim} (kN/m ²)
Clean sand	35	30	40	114.8
Silty sand	30	25	20	95.7
Sandy silt	25	20	12	81.3
Silt	20	15	8	67.0

Alternative method, based on CPT (cone penetration test) results, could be used to evaluate the skin friction and end bearing capacity as defined in the Annex A.17 of ISO 19902:2007.

4.4.4 Skin friction and end bearing capacity of piles grouted in rock

a) The unit skin friction capacity f, in kN/m², of grouted piles in rock may theoretically have an upper limit equal to the shear strength of the rock or of the grout. Actually, the f value may be considerably reduced in relation to the installation procedure and to the type of rock or of drilling fluid used.

An upper limit of f value for this kind of pile may be given by the allowable bond stress between the pile wall and the grout.

b) The end bearing capacity of the rock is to be determined from the shear strength of the rock itself

and an appropriate bearing capacity factor, but in any case it is not to exceed 10000 kN/m². Another detailed method to define the end bearing capacity is given in the paper “Grouted piles in weak carbonate rock” by A.F. Abbs and A. D. Needham. presented at 17th Offshore Technology Conference, Houston 1985 (OTC Paper number 4852)

4.5 Pile capacity for axial pullout loads

The ultimate axial pullout capacity of pile is not to exceed the total skin friction of pile Q_s.

The effective weight of the pile, including the soil plug and hydrostatic uplift, is to be considered.

For clay soils, the unit skin friction capacity f is to have the same values given in [4.4.2].

For sandy and silty soils, the same considerations given in [4.4.3] are applicable, except that K = 0,5 is to be used.

For rock, see [4.4.4].

The safety factors applicable to the ultimate axial pullout capacity of pile are to be the same as those given in [4.3].

4.6 Soil-pile interaction modelling

The capacity of the pile as defined in the previous paragraph represents the resistance parameter of this foundations type.

The behaviour of soil around piles is dependent upon many variables (e.g. type of soil, pile characteristic, installation method, and applied actions). The occurrence of these variables should be considered in soil-pile interaction modelling.

4.6.1 Axial performance

The axial resistance of the soil for pile compression is provided by a combination of axial soil-pile adhesion and associated shear transfer along the sides of the pile, and end bearing resistance at the pile tip. The relationship between mobilized soil-pile shear transfer and local pile displacement at any depth is described using a t-z curve. Similarly, the relationship between mobilized end bearing resistance and axial tip displacement is described using a Q-z curve.

The pile foundation is to be designed to resist the static and cyclic axial actions.

(t-z) curves - axial shear transfer curves

Various empirical and theoretical methods are available for developing curves for axial shear transfer and pile displacement as referenced in the Annex A.17.7.2 of the ISO 19902:2007. Curves developed from pile load tests in representative soil profiles or based on laboratory soil tests that model pile installation can also be justified. In the absence of more definitive criteria, the t-z curves recommended in in Subclause 17.7.2 of the ISO 19902:2007.

(Q-z) curves – end bearing resistance-displacement

SECTION 10 – DESIGN OF STATIONKEEPING STRUCTURES

The characteristic end bearing capacity is to be determined as described in [4.4.4]. In the absence of more definitive criteria, the prescriptions described in Subclause 17.7.3 of the ISO 19902:2007 are recommended for both sands and clays.

4.6.2 Lateral performance

The behaviour of the soil-pile system subjected to lateral loads is to be analysed on the basis of realistic relationships which relate the deformations to the soil reactions.

Such relationships, generally represented by (p-y) (soil reaction lateral deflection) curves, are characteristic of the type of soil, pile dimensions and loading application conditions (static, cyclic or impact loads).

The (p-y) curves may be constructed using the results of laboratory tests on soil samples; the influence of scour in proximity to the sea bottom and the disturbance caused by pile installation on the soil characteristics are to be taken into account.

In the absence of criteria which are more appropriate to the individual practical cases, the (p-y) curves may be constructed according to indications given in the following.

(p-y) curves for clay soils

a) For soft clay soils, the (p-y) curve for the layer of soil located at a depth z, in m, from the sea bottom may be represented by the broken line shown in Figure 4.1, generated by the values specified in Table 4.3.

b) For stiff clay soils (i.e. when $c > 96$ kPa according to ISO 19902:2007 Subclause 17.8.4), and for static loads, the same considerations in item a) above are applicable.

Instead, for cyclic loads a sharp deterioration of soil characteristics occurs due to high deformations, which result in considerable reduction of representative lateral capacity, p_r .

Figure 4.1 – (p-y) curve for soft clay soils

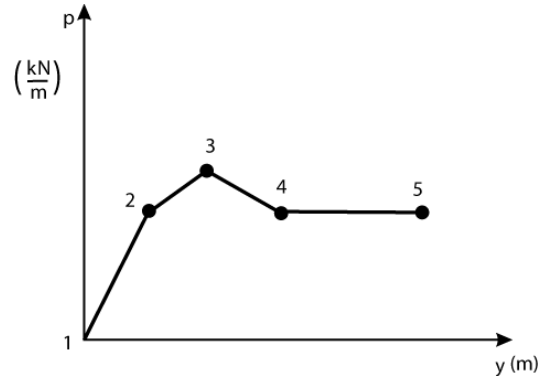

Table 4.3 – Coordinates of points for (p-y) curve for soft clay soils (ref. Figure 5.1).

SECTION 10 – DESIGN OF STATIONKEEPING STRUCTURES

(See also Table 17.8-1 of ISO 19902:2007)

Static load or short term action		
Point	p / p _u	y / y _c
1	0	0
2	0,5	1,0
3	0,72	3,0
4	1,00	8,0
5	1,00	∞
Cyclic load for z ≥ z _R		
Point	p / p _u	y / y _c
1	0	0
2	0,5	1,0
3	0,72	3,0
4 ≡ 5	0,72	∞
Cyclic load for z ≤ z _R		
Point	p / p _u	y / y _c
1	0	0
2	0,5	1,0
3	0,72	3,0
4	0,72 z / z _R	15,0
5	0,72 z / z _R	∞
<p>Note 1: y_c, in m, is given by the following equation: y_c = 2,5 · ε_c · D where: D : pile diameter, in m; ε_c : strain which occurs at one half the maximum stress on laboratory undrained compression tests of undisturbed soil samples; z_R : depth of reduced strength zone, in m, given by the following formula: $z_R = \frac{6D}{\frac{\gamma D}{c} + J}$ where: γ : effective specific gravity of soil (in water), in kN/m³; c : undrained shear strength of soil, in kN/m²; J : empirical coefficient, whose values are between 0,5 and 0,25 (in the absence of reliable information, 0,25 is to be used); p_u : ultimate soil resistance, in kN/m (force/unit length of pile), given by the following formulae: $p_u = \left(\frac{6c}{z_R} \cdot z + 3c \right) \cdot D \quad \text{for } z \leq z_R$ $p_u = 9 \cdot D \cdot c \quad \text{for } z > z_R$</p>		

(p-y) curves for sand soils

The (p-y) curve of the layer located at depth z is as shown in Figure 4.2 generated by abscissa and

ordinates of the points u, m and k, which may be computed as follows:

point u:

SECTION 10 – DESIGN OF STATIONKEEPING STRUCTURES

$$\begin{cases} y_u = \frac{3}{80} D \text{ (m)} \\ p_u = A \cdot p_c \text{ (kN/m)} \end{cases}$$

where:

- D : pile diameter, in m;
- A : empirical coefficient according to Figure 5.3;
- p_c : to be taken equal to p_{cs} if z ≤ z_t or equal p_{cu} if z > z_t, in kN/m:

$$p_{cd} = \gamma \left[\frac{k_0 z \tan \Phi \sin \beta}{\tan(\beta - \Phi) \cos \alpha} + \frac{\tan \beta}{\tan(\beta - \Phi)} (D + z \tan \beta \tan \alpha) + k_0 z \tan \beta (\tan \Phi \sin \beta - \tan \alpha) - k_a D \right]$$

$$p_{cs} = D \gamma z [k_a (\tan^8(\beta - 1) + k_0 \tan \Phi \tan^4 \beta)]$$

In any case, it could be useful consider the p_c as the minor value between p_{cs} and p_{cd} in order to avoid the overestimate of the lateral resistance as defined in Subclause 17.8.6 ISO 19902:2007.

- z_t : depth below soil surface to bottom, obtained when p_{cs} is equal to p_{cp}, in m;
- γ : effective specific gravity of sand (in water), in kN/m³;
- Φ : angle of internal friction of sand, in degrees;
- α : $\frac{\Phi}{2}$, in degrees;
- β : $45 + \frac{\Phi}{2}$, in degrees;
- k₀ : 0,4;
- k_a : $\text{tg}^2 \left(45 - \frac{\Phi}{2} \right) = \frac{(1 - \sin \Phi)}{(1 + \sin \Phi)}$

point m:

$$\begin{cases} y_m = \frac{1}{60} D \text{ (m)} \\ p_m = B p_c \text{ (kN/m)} \end{cases}$$

being B an empirical coefficient according to Figure 5.4.

point k:

determined by the intersection of the two lines given by the equations:

$$p = K z y \text{ (kN/m)}$$

$$p = C y^{1/n} \text{ (kN/m)}$$

where:

K : initial modulus of subgrade reaction depending on the grade of sand density, given in Table 5.4 ⁽¹⁾:

$$C = \frac{p_m}{y_m^{1/n}}$$

$$n = \frac{p_m}{m \cdot y_m}$$

$$m = \frac{p_u - p_m}{y_u - y}$$

Therefore, the abscissa and ordinate of point k are:

$$y_k = \left(\frac{C}{K \cdot z} \right)^{\frac{n}{n-1}} \text{ (m)}$$

$$p_k = K \cdot z \cdot y_k \text{ (kN/m)}$$

For some combinations of the parameters involved, the K value may result in a deflection y_k greater than y_m, in which case the parabolic portion of the (p-y) curve is to be omitted.

Note:

(1) The initial modulus of subgrade reaction represent the soil in the Winkler method. It consider the soil as equivalent spring and K represent the stiffness of the spring.

Figure 4.2 – (p-y) curve for sand soils.

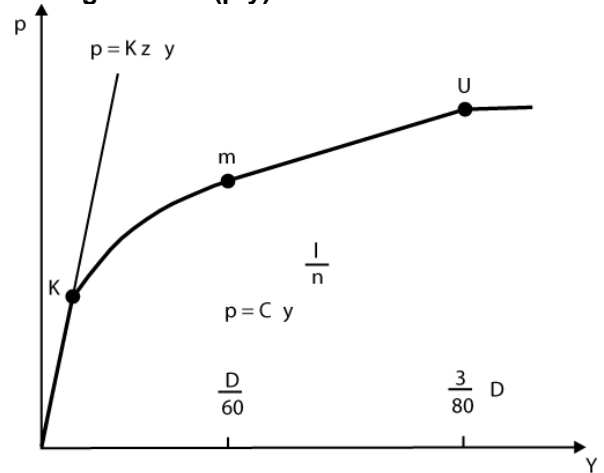

Figure 4.3 – Empirical coefficient A as a function of z/D.

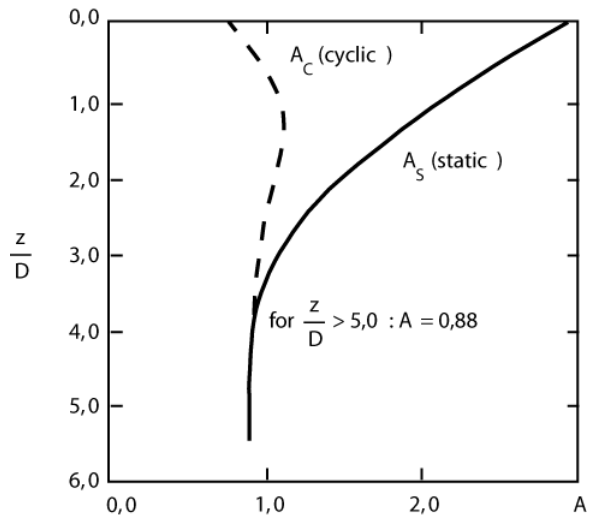

Figure 4.4 – Empirical coefficient B as a function of z/D.

SECTION 10 – DESIGN OF STATIONKEEPING STRUCTURES

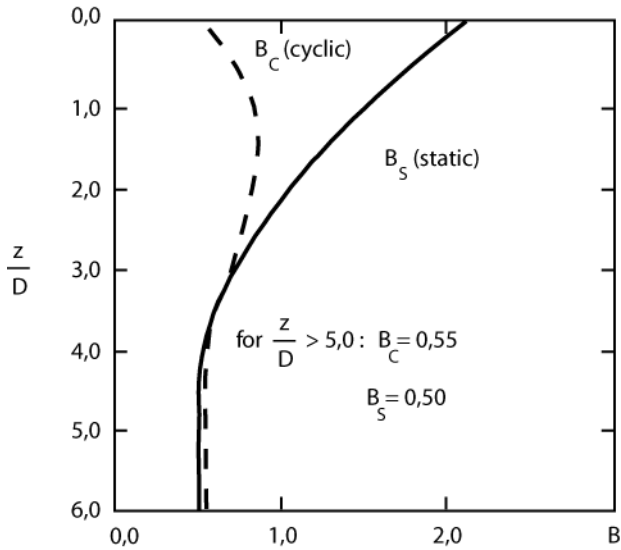

Table 4.4 – Initial modulus of subgrade reaction as a function of grade of sand density.

DENSITY	K (kN/m ³)
loose	5400
medium	16300
dense	33900

4.7 Group effects

The axial and lateral bearing capacity of a group of piles depends on several factors such as pile characteristics, type and strength of soil, sequence of soil layers, pile installation method, etc..

The knowledge on this subject is rather limited and therefore the strength calculation of the group is to be carried out on the basis of conservative assumptions, due consideration being given to the possibility that the actual spacing of piles is less than that assumed for the design due to a non-perfect installation.

First of all the group effects have to be considered where piles spacing are less than eight diameters.

Where more reliable data are not available, the following considerations are applicable:

- a) the end bearing capacity of the group in homogeneous soils may be taken equal to the sum of the single pile contributions;
- b) the skin friction capacity of the pile group is to be taken equal to the sum of the single pile contributions multiplied by a reduction factor R, given by the following formula:

$$R = \frac{p}{\sum \pi \cdot D_i}$$

- p : external perimeter of the group, in m;
- D_i : diameter of the i-pile, in m;
- N : number of the piles.

Such a reduction is required in any case for sandy soils, while it may be neglected for clay soils when the ratio of the minimum spacing of piles to the pile diameter exceeds the value 0,785 (N0,5 + 1).

If R > 1, is to be assumed R = 1.

4.8 Pipe wall thickness

- a) The D/t ratio of pile diameter to thickness is to be such as to preclude the possibility of occurrence of local buckling during the installation operations and the operation life of the foundation.
- b) In general, the pile wall thickness is not constant for the entire length of the pile, but varies with the anticipated stress level, which is normally highest in the portion close to the sea bed. It is recommended that the heavy wall thickness of the pile is extended for a reasonable length to take account of the two possibilities of not achieving the foreseen penetration or of being compelled to exceed it in order to reach a layer with high bearing capacity.
- c) It is recommended that the end of the pile is provided with a driving shoe having a thickness increased by 50% in respect of that mentioned in item a) above.

For detailed information on pipe wall requirements , reference can be made to Subclause 17.10 of ISO 19902:2007

SECTION 11 – FLOATING STABILITY

1 General requirements

This section provides general requirements for stability for maintaining the normal operation of a unmanned floating wind turbine unit. For the purpose of this item all references are made to RINA rules for the classification of ships.

2 Stability in Service

The floating wind turbine unit shall have positive stability during operation at the wind speed that produces the largest rotor thrust.

The floating structure shall also be capable of maintaining stability during standstill of the wind turbine in severe storm conditions. These conditions shall be defined in consistence with the metocean conditions of the target environmental data. The procedures recommended and the approximate length of time required, considering both operating conditions and transit conditions, shall be contained in the stability manual.

3 Inclining test/Lightweight check

An inclining test should be required for the first unit of given design, when the unit is as near to completion as possible, to determine accurately the light ship data (weight and position of centre of gravity).

RINA may allow a lightweight check to be carried out in lieu of an inclining test in the case of:

- a) an individual unit, provided basic stability data are available from the inclining test of a unit which is identical by design and a lightweight check is performed in order to prove that the sister unit corresponds to the prototype unit. The lightweight check is to be carried out upon the unit's completion. The final stability data to be considered for the unit which is identical by design in terms of displacement and position of the centre of gravity are those of the prototype. Whenever, in comparison with the data derived from the prototype, a deviation from the lightship displacement exceeding 1% or a deviation from the lightship (where lightship is the displacement of a unit in tonnes without variable deck load, fuel, lubricating oil, ballast water, fresh water and feedwater in tanks, consumable stores, and personnel and their effects) longitudinal centre of gravity exceeding 0,5% of length is found, the unit is to be inclined. Extra care should be given to the detailed weight calculation and comparison with the original unit of a series of column-stabilized, semisubmersible types as these, even though identical by design, are recognized as being unlikely

to attain an acceptable similarity of weight or centre of gravity to warrant a waiver of the inclining test.

- b) special designs, provided that:
 - detailed list of weights and the positions of their centres of gravity is submitted;
 - lightweight check is carried out, showing accordance between the estimated values and those determined adequate stability is demonstrated in all the loading conditions reported in the trim and stability booklet.

For units which have undergone work of minor importance and for which the weights and the centres of gravity of shipped and unshipped loads are known, the new displacement and centre of gravity obtained from calculation carried out on the basis of the original data are deemed satisfactory.

The results of the inclining test, or those of the lightweight survey together with the inclining test results for the first unit should be indicated in the operating manual.

4 Righting moment and heeling moment curves

Curves of righting moments and of wind heeling moments similar to figure 11-1 with supporting calculations should be prepared covering the full range of operating draughts, including those in transit conditions, taking into account the maximum loading of materials in the most unfavourable position applicable. The righting moment curves and wind heeling moment curves should be related to the most critical axes. Account should be taken of the free surface of liquids in tanks.

Where equipment is of such a nature that it can be lowered and stowed, additional wind heeling moment curves may be necessary and such data should clearly indicate the position of such equipment. Provisions regarding the lowering and effective stowage of such equipment should be included in the operating manual. Heeling moment may be determinate from wind tunnel or wind basin tests on a representative model of the unit fitted with a realistic wind turbine operating in an appropriate wind environment at its designed torque loading. Alternatively, turbine manufacturers certified data for the thrust loading from their turbine at different operating speeds may be used for the turbine wind heeling component.

Such heeling moment determination should include lift and drag effects at various applicable heel angles.

In case model test for a specific unit or comparability model test results are not available Pt E, Ch 6, Sec 3 par 3 of RINA Rules for Floating offshore Units and MODU (RES 17/E) may be used.

SECTION 11 – FLOATING STABILITY

Figure 11-1: Righting moment and heeling moment curves

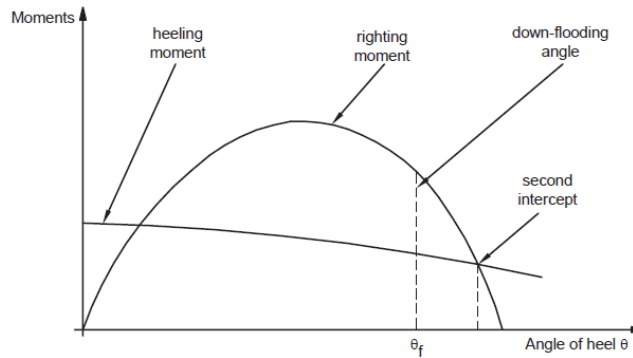

Area (A + B) > 1,4 or 1,3 Area (B + C)

5 Intact Stability

5.1 Surface units and column stabilized units

The stability of a unit in each mode of operation is to meet the following criteria (see also Fig 11-1).

- a) For surface units the area under the righting moment curve to the second intercept or downflooding angle, whichever is less, is to be not less than 40% in excess of the area under the wind heeling moment curve to the same limiting angle;
- b) For column-stabilized units the area under the righting moment curve to the angle of downflooding is to be not less than 30% in excess of the area under the wind heeling moment curve to the same limiting angle.
- c) The righting moment curve is to be positive over the entire range of angles from upright to the second intercept.
- d) A check is to be carried out to assess that the lesser of the downflooding angle and the second intercept angle is not greater than the following angles:
 - the angle for which the stresses of whichever primary structural element become excessive;
 - the limit angle for which lashes of loads on the decks are calculated.

It is to be possible to achieve the severe storm condition without the removal or relocation of solid consumables or another variable load. However, the Society may permit loading a unit past the point at which solid consumables would have to be removed or relocated to go to severe storm condition under the following conditions, provided the allowable KG requirement is not exceeded:

- a) in a geographic location where weather conditions annually or seasonally do not become sufficiently severe to require a unit to go to severe storm condition, or
- b) where a unit is required to support extra deckload for a short period of time that falls well within a period for which the weather forecast is favourable.

The geographic locations, weather conditions and loading conditions in which this is permitted are to be identified in the Operating Manual.

Alternative stability criteria may be considered by the Society provided an equivalent level of safety is maintained and if they are demonstrated to afford adequate positive initial stability. In determining the acceptability of such criteria, the Society may consider at least the following and take into account as appropriate:

- a) environmental conditions representing realistic winds (including gusts) and waves appropriate for world-wide service in various modes of operation;
- b) dynamic response of a unit. Analysis is to include the results of wind tunnel tests, wave tank model tests, and non-linear simulation, where appropriate. Any wind and wave spectra used is to cover sufficient frequency ranges to ensure that critical motion responses are obtained;
- c) potential for flooding taking into account dynamic responses and wave profile in a seaway;
- d) susceptibility to capsizing considering the unit's restoration energy and the static inclination due to the mean wind speed and the maximum dynamic response;

SECTION 11 – FLOATING STABILITY

- e) an adequate safety margin to account for uncertainties;
- f) equivalent damage and flooding criteria.

5.2 Spar units

For spar units the metacentric height GM shall be equal to or greater than 1.2 m.

5.3 Tension leg platforms

For tension leg platforms only stability during transfer operation shall be verified. During operation the COG shall be identified and the shift of its position shall be calculated based on maximum and minimum allowable tendon tension.

6 Watertight Integrity

6.1 General

The number of openings in watertight subdivisions is to be kept to a minimum compatible with the design and proper working of the unit. Where penetrations of watertight decks and bulkheads are necessary for access, piping, ventilation, electrical cables, etc., arrangements are to be made to maintain the watertight integrity of the enclosed compartments.

Where valves are provided at watertight boundaries to maintain watertight integrity, these valves are to be capable of being operated from a pump-room or other normally manned space, a weather deck, or a deck which is above the final waterline after flooding. In the case of a column-stabilized unit this would be the central ballast control station.

Valve position indicators are to be provided at the remote-control station.

All surface type units, excluding therefore column stabilized units, are to be fitted with a collision bulkhead.

Sluice valves, cocks, manholes, watertight doors, etc. are not to be fitted in the collision bulkhead.

Elsewhere, watertight bulkheads are to be fitted as necessary to provide transverse strength and subdivision.

6.2 Watertight doors

The net thickness of watertight doors is to be not less than that of the adjacent bulkhead plating, taking account of their actual spacing.

Where vertical stiffeners are cut in way of watertight doors, reinforced stiffeners are to be fitted on each side of the door and suitably overlapped; cross-bars are to be provided to support the interrupted stiffeners.

Watertight doors required to be open at sea are to be of the sliding type and capable of being operated both at the door itself, on both sides, and from an accessible position above the bulkhead deck.

Means are to be provided at the latter position to indicate whether the door is open or closed, as well as

arrows indicating the direction in which the operating gear is to be operated.

Watertight doors may be of the hinged type if they are always intended to be closed during navigation.

Such doors are to be framed and capable of being secured watertight by handle-operated wedges which are suitably spaced and operable at both sides.

7 Closing appliances

7.1 General requirements related to intact stability for surface units

Even if not applicable, Load lines are anyway suggested to be assigned to surface units as calculated under the terms of the 1966 Load Line Convention and all the conditions of assignment of that Convention.

Where it is necessary to assign a greater than minimum freeboard to meet intact requirements or on account of any other restriction imposed by RINA, Regulation 6(6) of the 1966 Load Line Convention is to apply. When such a freeboard is assigned, seasonal marks above the centre of the ring are not to be marked and any seasonal marks below the centre of the ring are to be marked. If a unit is assigned a greater than minimum freeboard at the request of the owner, Regulation 6(6) need not apply.

In cases of small notches or relatively narrow cut-outs within the hull in open communication with the sea, the volume of the cut-out is not to be included in the calculation of any hydrostatic properties. If the cut-out has a larger cross-sectional area above the waterline at 0,85 D than below, an addition is to be made to the geometric freeboard corresponding to the lost buoyancy. This addition for the excess portion above the waterline at 0,85 D is to be made as prescribed below for wells or recesses. If an enclosed superstructure contains part of the cut-out, deduction is to be made for the effective length of the superstructure.

Where open wells or recesses are arranged in the freeboard deck, a correction equal to the volume of the well or recess to the freeboard deck divided by the waterplane area at 0,85 D is to be made to the freeboard obtained after all other corrections, except bow height correction, have been made. Free surface effects of the flooded well or recess are to be taken into account in stability calculations.

Narrow wing extensions at the stern of the unit are to be considered as appendages and excluded for the determination of length (L) and for the calculation of freeboards. RINA is to determine the effect of such wing extensions with regard to the requirements for the strength of unit based upon length (L).

7.2 General requirements related to intact stability for column stabilized units

The hull form of this type of unit makes the calculation of geometric freeboard in accordance with the provisions of Chapter III of the 1966 Load Line

SECTION 11 – FLOATING STABILITY

Convention impracticable. Therefore, the minimum freeboard of each column-stabilized unit is to be determined by meeting the applicable requirements for:

- a) the strength of the unit's structures;
- b) the minimum clearance between passing wave crests and deck structure; and
- c) intact stability requirements.

The minimum freeboard is to be marked in appropriate locations on the structure.

8 Icing

Icing formation adversely affect the stability of the unit therefore it can be calculate in accordance with Pt B, Ch 3, Sec 2, [6] of RINA Rules REP2.

9 Effects of free surfaces of liquids in Tanks

For all loading conditions, the initial metacentric height and the righting lever curve are to be corrected for the effect of free surfaces of liquids in tanks therefore it can be calculate in accordance with Pt B, Ch 3, Sec 2, [4] of RINA Rules REP2.

SECTION 12 – MACHINERY AND ELECTRICAL SYSTEMS

1 General requirements

This section provides a guide for the design and the installation of various machinery and electrical systems on a Floating Offshore Wind Turbine. For the purpose of this item all references are made to RINA rules for the classification of ships.

2 Machinery Systems

2.1 Bilge system

An efficient bilge pumping system shall be provided, capable of pumping from and draining any watertight compartment other than a space permanently appropriated for the carriage of fresh water, water ballast, fuel oil or liquid cargo and for which other efficient means of pumping are to be provided, under all practical conditions. An automatic Bilge level detection and associated control of pumps may be provided (System category II, Pt C, Ch 3, Sec 3).

Bilge system is to be designed according to the requirements listed in Pt E, Ch 19, Sec. 3, [2] except para [2.2.5].

2.2 Ballast Water System

All tanks intended for ballast water are to be provided with suitable filling and suction pipes connected to special power driven pumps of adequate capacity.

Suctions are to be so positioned that the transfer of sea water can be suitably carried out in the normal operating conditions of the unit.

A Ballast transfer valves remote control system may be provided (System category II, Pt C, Ch 3, Sec 3).

Ballast systems may be powered by bilge systems or by compressed air systems. Ballast systems shall provide capability to ballast and de-ballast all ballast tanks except those that are used as permanent ballast tanks only. Ballast system is to be designed according to the requirements listed in Pt C, Ch 1, Sec 10, [7] as far as applicable.

2.3 Ventilation Arrangement

Spaces containing main and auxiliary machinery are to be provided with adequate ventilation.

Machinery spaces are to be sufficiently ventilated so as to ensure that when machinery or boilers therein are operating at full power in all weather conditions, including heavy weather, an adequate supply of air is maintained to the spaces for the safety and comfort of personnel and the operation of the machinery.

The ventilation is to be so arranged as to prevent any accumulation of flammable gases or vapors.

Means are to be provided to verify the minimum oxygen level inside the compartment.

2.4 Air vent & sounding pipe

Air pipes are to be fitted to all tanks, double bottoms, cofferdams, tunnels and other compartments which are not fitted with alternative ventilation arrangements, in

order to allow the passage of air or liquid so as to prevent excessive pressure or vacuum in the tanks or compartments, in particular in those which are fitted with piping installations.

Their open ends are to be so arranged to prevent the free entry of sea water in the compartments.

Air vent and sounding pipe are to be designed according to the requirements listed in Pt E, Ch 19, Sec 3, [3.1.6] as far as applicable.

2.5 Mooring equipment

A mooring system is to be designed to minimize its sensitivity to environmental factors and to operational demands and to make its construction and inspection easier.

Mooring equipment, such as chains, winches and windlasses, chain stoppers, fairleads and systems for tensioning the mooring lines, are to be designed in accordance with RINA Rules (Pt. F, Ch 13, Sec 21) as far as applicable.

2.6 Dynamic control systems

The positioning of the floating offshore wind turbine may be automatic controlled through a dedicated control system, acting on the mooring and the ballast water systems.

In particular the vertical distance from the sea level and the wind turbine orientation against the wind direction can be automatically adjusted.

2.6.1 Vertical control system

Vertical control system is to be designed to act contemporary both on the ballast system and the mooring equipment to achieve the desired height of the turbine compared to the sea waterline.

Vertical control system is to control the floating offshore wind turbine movement along its vertical axis based on the specific operating limits.

Operating limits of each floating offshore wind turbine are under the Manufacturer responsibility.

2.6.2 Control and sensors

Control systems and sensors are to be designed and selected according to the requirements listed in Pt C, Ch 3, as far as applicable.

Control systems are to be designed to operate in fully unmanned mode for an unlimited period of time.

2.7 Dynamic ballast control system

The dynamic ballast control system is to be designed to allow the automatic operation of pumps and valves of the system.

Dynamic ballast control system shall include ballast water tanks level sensors, draft sensor and/or motion reference unit.

Ballast system auxiliaries are to be designed and arranged to operate as an unmanned system.

SECTION 12 – MACHINERY AND ELECTRICAL SYSTEMS

2.8 Dynamic mooring system

The dynamic mooring system is to be designed to allow the automatic operation of winches or heave compensation system to adjust the unit draft automatically.

Dynamic mooring system includes the sensors (e.g. load sensors and/or motion reference unit) to detect the tensions acting on the mooring lines.

Mooring system auxiliaries are to be designed and arranged to operate as an unmanned system.

2.9 Wind-direction follow-up

Wind-direction control system, if any, allows the upper part of the floating offshore wind turbine to rotate along its vertical axis based on the specific operating requirement.

Operating limits of each floating offshore wind turbine are under the Manufacturer responsibility.

2.10 Transmission system and brake

The gearing system of a floating offshore wind turbine allowing its rotation along its vertical axis, is to be designed according to the requirements listed in Pt C, Ch 1, Sec 6 and Pt C, Ch 1, Sec 11 as far as applicable. A reliable blocking device is to be provided to block the turning system for maintenance purpose.

The blocking device is to be manually controlled and not depending on a source of energy to remain blocked and it shall allow the safe removal of the electrical motor and its mechanical transmission.

2.11 Fire detection & Firefighting System

The unit is to be provided of a reliable fire detection system and a fixed fire-fighting system.

Fire detection system and fire-fighting system are to be provided with a dedicated power supply.

The operation of the fixed fire-fighting system, and its automatic activation, is to be combined with the fire detection system.

Fire detection and fire-fighting system is to be designed according to the requirements listed in Pt C, Ch 4 as far as applicable.

3 Electrical

3.1 General

A main source of electrical power of sufficient capacity to supply all electrical/electronic devices needed for the proper operation of the unit shall be provided.

The main source of electrical power may consist in batteries backed-up with shore power connection.

Storage batteries of the lead-acid or nickel-alkaline type are to follow the requirements of Pt C, Ch 2, Sec 7, [1].

Storage batteries other than Lead-acid or alkaline batteries is allowed subject to the compliance of the battery system and its installation to the requirements given in Pt C, Ch 2, App 2.

Battery chargers are to be designed according to the requirements Pt C, Ch 2, Sec 7, [2].

UPSs are to be designed according to the requirements Pt C, Ch 2, Sec 7, [3].

Batteries and electric circuits are to be designed and protected according to the requirements of Pt C, Ch 2 Sec 3.

Electrical system is to be suitably designed to reduce to the minimum possible the electrical power consumption when the unit is in unmanned conditions. Battery system is to be charged from shore power; alternatively, charge power may be supplied by the wind generator provided that the system is adequately electrically protected, and adequate safety and reliability levels are ensured.

Spaces containing main and auxiliary machinery are to be provided with adequate lighting.

A dedicated FMEA study of electrical and control systems, air compressed systems, hydraulic systems is to be provided.

A dedicated Risk Assessment is to be provided for the wind farm. The analysis should include:

- electrical systems,
- electronic systems,
- auxiliary systems,
- mechanical systems,
- air compressed systems,
- hydraulic systems,
- fire detection & firefighting system,
- field environmental conditions,
- operating limits of the whole unit.

3.2 Export Electrical Cable System

The installation and connection of exporting electrical cable is to be according to the requirement of Pt C, Ch 2, Sec 12 as far as applicable.

Sub marine power cables are to be in compliance with the standard IEC 63026.

3.3 Lightning protection

General information relevant to the lightning phenomenon and the processes involved when lightning interact with wind turbine are provided by IEC 61400-24, Annex A.

Lighting Protection Levels from I to IV are to be considered with reference to IEC 62305-1.

For each LPL a set of maximum and minimum lighting current parameters is fixed (ref. IEC 61400-24, Table 1 and Table 2).

The goal of any lightning protection system is to reduce the hazards to a tolerable level, which is based on an acceptable risk if human safety is involved.

The lightning protection is furthermore a precaution against economical losses due to damage and loss of revenue.

Guidance on how to make a simple lightning exposure assessment for individual wind turbines, and how to extend it to groups of WT and wind farms is given by IEC 61400-24, Subclause 7.

SECTION 12 – MACHINERY AND ELECTRICAL SYSTEMS

Lightning protection and verification for the floating wind turbine installation is to be carried out, for the following components:

- Blades, which are the most exposed parts of the turbine;
- Nacelle;
- Tower;
- Mechanical drive train;
- Yaw system;
- Electrical and control systems,

in compliance with the applicable requirements of IEC 61400-24.

An efficient earthing system for the wind turbine is also to be provided, to disperse lightning currents and prevent damage to the wind turbine, in accordance to IEC 61400-24, Subclause 9) requirements.

SECTION 13 – PROTECTION AGAINST CORROSION

1 General

This section provides principles, technical requirements and guidance for the corrosion protection of the structural components of the floating offshore wind turbine installation.

1.1 General requirements

All steel structures are to be protected against corrosion in relation to adopted materials, service conditions and expected operating life.

For reinforced concrete, or prestressed reinforced concrete, structures, the steel reinforcements are to be covered and surrounded by high-quality, well compacted, homogeneous concrete layer, that is to be adequately provided by taking into account the target adopted for the crack width limit state verification.

The corrosion protection systems adopted, their design, the relevant materials used and the manufacturing and installation procedures are subject to approval by RINA according to the certification purpose.

Special consideration is to be given to the protection of steel members that are difficult to inspect or repair after installation and of those members located in particularly aggressive environments, such as the splash zone.

1.2 Splash zone definition

For external surfaces of the floating support structure, the splash zone is that portion of the structure between the following heights measured from the sea bottom:

- the water level on the floater corresponding to maximum tide in combination with the deepest operational draft plus the crest elevation of the 1-year return period significant wave height, and plus the foundation settlement, if applicable;
- the water level on the floater corresponding to minimum tide in combination with the lower operational draft minus the trough depth of the 1-year return period significant wave height, and plus the foundation settlement, if applicable.

For heave restrained floaters, such as TLPs, the splash zone is that portion of the structure between the following heights measured from the sea bottom:

- sea depth plus the maximum tide and 65% of the wave height having recurrence frequency equal to 0.01;
- sea depth minus the minimum tide and 35% of the above wave height.

2 Corrosion protection systems

2.1 General

Special corrosion protection systems are to be provided for structural steel members in the splash zone in addition to possible increase in thickness at design stage accounting for expected corrosion rate (see [2.5]).

Structures above the splash zone are normally to be protected by painting.

Metallic surfaces below the splash zone, including surfaces of embedded members (such as piles, skirts, etc.), are to be protected by a cathodic protection system or by impressed current.

Possible internal surfaces of structures exposed to sea water are to be protected, as far as applicable, both by a cathodic system and by coating.

In any case, the use of impressed current is to be avoided in spaces where the water change is inhibited or considerably restricted.

Protective systems other than those above may be accepted at the discretion of RINA.

2.2 Selection criteria

Besides general aspects, such as:

- contingent local requirements;
- type and severity of foreseen corrosion;
- design service life (including possible lifetime extension, if required);
- accessibility for inspection and maintenance;
- suitability, reliability and availability of different techniques for corrosion control,

the selection and design of the specific corrosion protection system is to be based, at least, on the following parameters, depending on the location and function of the different components of the offshore installation:

- parameters characterizing the sea water and sea bottom environment:
 - temperature;
 - oxygen content;
 - chemical composition;
 - resistivity;
 - pH value;
 - sea current velocity;
 - erosion due to suspended solids;
 - biological activity.
- parameters affecting the environment of the internal surfaces:
 - humidity;
 - condensation;
 - temperature;
 - properties of electrolytes;
 - corrosivity of substances which may be present.
- parameters relevant to surfaces to be protected:
 - shape;
 - location;
 - effects of damage due to corrosion;
 - possibility of inspection and repair.
- parameters relevant to interface with export electrical cable:
 - effect on corrosion rate on the structural interface of the floater unit at the attachment point of the power cable

SECTION 13 – PROTECTION AGAINST CORROSION

2.3 Protection by coating systems

2.3.1 Definitions

Coating is made by thin (<1mm) single or multiple organic or metallic layers, applied by spraying, brushing or dipping;
Cladding, lining and wrapping are corrosion protective layers (≥1mm) applied in order to avoid wave action erosion (for the submerged structure or piping) or fouling and external corrosion.

2.3.2 Protection by coating

The design of all components to be paint coated shall take into account the need of easing both the initial application and following maintenance.

Approval of protective coating systems will be granted on the basis of information relating to:

- type and trademark of coating;
- adhesion and resistance to sea water;
- service temperature;
- resistance to ageing;
- resistance to mechanical damage;
- resistance to deterioration caused by cathodic overprotection;
- compatibility of different types of coatings applied;
- possibility of repairs during construction, installation and service;
- procedure and directions for the application.

The preparation of surfaces and the application of coating are to be performed when the surface temperature exceeds the dew point by at least 3°C, or when the relative humidity of the air is below 85% or as recommended in the Manufacturer's specifications.

2.3.3 Protection by cladding or lining

Protection by cladding or lining systems is to be carried out on the basis of information relevant to:

- type and trademark of cladding or lining;
- resistance to pollutant elements;
- service temperature, pressure, partial pressure or fugacity;
- resistance to mechanical damage;
- possibility of repairs during construction, installation and service;
- procedure and directions for the application.

2.4 Cathodic protection

2.4.1 General

Cathodic protection is applicable to the submerged and the buried zones. Cathodic protection may be realized by:

- galvanic (sacrificial) anodes,
- impressed current (IC) from one or more rectifiers.

2.4.2 Protection by sacrificial anodes

Approval of sacrificial anode protection systems is based on examination of information relating to:

- area of surfaces to be protected;
- electrical connections;
- density of protective current;
- total number, distribution and characteristics of anodes;
- method of calculation used for the determination of the number and size of anodes to be fitted;
- anode installation;
- monitoring system.

The cathodic protection system is to supply a current sufficient to maintain the potential values given in Table 13-1 at all points of surfaces to be protected.

Table 13-1: Potential, in volts, for cathodic protection

Type of steel	Reference electrode		
	Cu/Cu SO ₄	Ag/Ag Cl	Zn
Steel in aerobic environment:			
a) upper limit	- 0,85	- 0,80	+ 0,25
b) lower limit	- 1,10	- 1,05	0,00
Steel in anaerobic environment:			
a) upper limit	- 0,95	- 0,90	+ 0,15
b) lower limit	- 1,10	- 1,05	0,00
Higher strength steel (ultimate tensile strength >800 N/mm ²)			
a) upper limit	- 0,85	- 0,80	+ 0,25
b) lower limit	- 1,00	- 0,95	+ 0,10

The design current density is to be based on the environmental service conditions of the structure.
The presence of stray currents (induced by welding processes by connection between structural members of different material etc.) and their possible influence on the cathodic protection system are to be carefully considered.

Metallic structures which do not belong to the floating support structure of the installation but are electrically connected to it are to be considered in the design of the cathodic protection system.
The required potential is to be maintained for the whole design life of the structure.

SECTION 13 – PROTECTION AGAINST CORROSION

The potential difference with close circuit ΔV and the electrochemical efficiency of sacrificial anodes are to be documented by appropriate tests.

Each anode is to be capable of delivering the total protective current (protective current density per total surface to be protected).

The method of calculation of the current delivered by each anode is to be submitted to RINA for approval.

The anodes are to be located so as to give a uniform current distribution over the whole steel structure.

The lifetime T of an anode, in years, is to be determined by the following formula:

$$T = \frac{M \cdot r}{I} \cdot f \cdot C$$

where:

M : net mass of the anode, in kg;

r : anode efficiency;

I : mean current output during the lifetime T, in A;

f : utilisation factor, to be taken equal to 0.8;

C : theoretical current output of the anode, defined as the mean current output in one year per unit mass of the anode, in (A*year)/kg.

For guidance, the following maximum values of anode efficiency r are given:

- for slender anodes: 0.9
- for other shapes of anodes: 0.8.

The anode core and supports are to be designed so as to ensure the anode integrity during all phases of the design life of the structure.

A permanent monitoring system is to be installed for measuring the potential at locations where inspection is impracticable.

An effective electrical connection is to be provided between anodes and the structure to be protected; welded connections are recommended for this purpose.

In positioning the anodes, due regard is to be given to structural points while direct connections to areas subject to high stress level are to be avoided.

Welding between anodes and structural members is to be carried out according to procedures which comply with those adopted for the fabrication of the structural members themselves.

2.4.3 Protection by impressed current

The corrosion protection system by impressed current is to be carried out based on information relating to:

- area of surfaces to be protected;
- electrical connections;
- current density;
- general arrangement;
- anodes, anode shielding, rectifiers, cables, cable connections and electrical circuits;
- monitoring system.

The anodes of the system are to be located and shielded so as to give a uniform current distribution of all surfaces to be protected.

The structure is to be provided with suitable instrumentation for measuring of the potential.

The electric current generator is to be tested to check that electrical connections are adequate and no damage has occurred during the installation.

Cables and electrical connections are to be carefully inspected to detect possible insulation defects, which are, in any event, to be properly repaired.

Anodes are to be inspected to check that their shape and material are in accordance with design specifications.

2.5 Corrosion allowance

2.5.1 General

A corrosion allowance (i.e. steel thickness increase to compensate for the effect of metal loss by corrosion on structural integrity) can be used alone or in combination with a coating to maintain the structural component or the pressure equipment with the required safety margin against expected corrosion rate. The extra thickness accounting for any corrosion allowance at design stage is to be determined taking expected corrosivity, design service life and maintenance measures into consideration.

2.5.2 Corrosion allowance for internal compartments

Internal compartments not protected by coating require corrosion allowance to be considered in steel plating design, by assuming a corrosion ratio value generally depending, in addition to the steel characteristics, on:

- Level of sealing (provided by welding) in the compartment;
- Level of humidity and oxygen in the compartment;
- Maintenance measures and inspection time intervals;
- Type of ballast (liquid and/or solid).

In case a control system by exclusion of oxygen is adopted as a reliable measure against corrosion in internal compartments of the floating support structure, no corrosion allowance is required.

For solid ballast used in internal compartments, e.g., of spars, the solid ballast shall not contain sulphides.

2.5.3 Corrosion allowance for chains

Corrosion allowance for chains used as mooring lines is to be provided by an increase in the chain links diameter; minimum values for such corrosion allowance are to be taken depending on a corrosion ratio value (in mm/year) that can be assumed based on site-specific conditions or values typically reported by recognized international standards for steel offshore mooring systems, specifically provided for the different parts of the mooring line (i.e. splash zone, catenary, bottom).

SECTION 13 – PROTECTION AGAINST CORROSION

2.6 Installation and testing of effectiveness of the systems

2.6.1 General requirements

After each cathodic protection system has been put into operation, testing is to be carried out to ensure that the steel structure potential is within the required range.

This testing is to be carried out within:

- one year for sacrificial anode systems;
- one month for impressed current systems.

The test equipment and procedure, as well as the number of measurements of the potential to be carried out, are to be approved by RINA.

The reference electrode is to be positioned as close as possible to the surface point selected for the measurement.

SECTION 14 – MARINE OPERATIONS

1 General requirements

1.1 Application

This Section applies to all marine operations necessary for the construction, transportation and installation of the offshore wind turbines, including their towers, their floating support structures and their station-keeping systems, limited to those aspects of such operations which may influence the safety of the whole structure or of some of its components.

As "Marine Operation" it is meant whatever activity performed in marine environment in order to transport, install or remove the offshore wind turbines, including the engineering design and planning of the activity itself.

As the requirements of this Section cover various types of structures and several types of operations, it is understood that the various provisions are to be applied when appropriate in relation to the type of structure and operation concerned.

Procedures and solutions other than those specified in this Section will be specially considered on a case by case basis.

1.2 Planning and execution

All marine operations are to be based, as far as practicable, on well-proven technologies and performed by qualified personnel.

Planning of the marine operations is to be undertaken by considering that the installation of a floating offshore wind turbine unit pertaining a large wind farm involves a logistic study that is to be carried out before relevant installation of the units, and, as such, is main part of the operation planning.

For instance, inshore storage premises for the fabricated units may be required, when, e.g., the installation is dependent on preinstalled anchoring components or when final offshore positioning and installation is subject to appropriate weather forecast.

In addition to the logistic study, as part of the operations planning, appropriate site surveys, relevant to seabed topography and bathymetry, covering the whole transportation route between the inshore storage site and the wind farm site, are to be carried out to provide reliable information applicable for the anchor installation and for the maximum allowable draught during the floating units' transportation.

The marine operations for transport and installation are to be carried out in accordance to best practice and recognized international standards applicable for the specific type of offshore installation.

General reference, for planning and execution of the marine operations relevant to offshore platforms to be installed in fixed locations, can be made to ISO 19901-6, as far as applicable.

1.3 Documentation and supervision

Marine operations are to be carried out in accordance with approved procedures and under RINA supervision.

The procedures and the main supporting documents for the operation design and planning are to be included in the "Marine Operation Manual" and should be prepared and submitted for RINA approval sufficiently in advance prior to the start of the operations.

The "Marine Operations Manual" is to include a detailed description of the operations and cover all the main aspects of operations, both for normal and emergency conditions, such as:

- organisation and communications;
- data and characteristics of vessels;
- systems and equipment involved;
- limitations imposed by:
 - environmental conditions
 - structural strength
 - hydrostatic stability;
 - operational procedures;
 - monitoring systems;
 - contingency measures.

For further recommendations relating to documentation requirements, general reference can be made to Clause 6.5 of ISO 19901-6.

1.4 Environmental actions

Characteristic parameters relating to the design environmental conditions for the start and the execution of single operations are to be specified in the "Marine Operations Manual" and submitted to RINA.

Acting loads and their effects during marine operations are to be determined in accordance with requirements of Section 4, [5] of this Guide.

1.5 Structural analysis

Analysis of the structure in the floating condition, or during launching, float-off, lifting, upending and other transportation/transit modes, is to be performed in accordance with the requirements of this Guide (Sec 9 in particular) and/or applicable parts of ISO 19904-1 and ISO 19902 (Clauses 12 and 22), depending on the type of floating support structure.

1.6 Weight control

Marine operations are particularly sensitive to the weight of the items to be moved and installed. A careful activity of weight control is to be put in place, according to Clause 8 of ISO 19901-6.

1.7 Floating stability

The requirements of this item apply to a floating system which may consist of the floating support structure and any wind turbine components, support and arrangements that can be present, being constructed onshore, during sea transportation.

SECTION 14 – MARINE OPERATIONS

The floating system is to have sufficient stability and reserve of buoyancy during all stages of marine operations.

The following requirements are to be complied with in all installation phases:

- the actual metacentric height of the system is to be at least 1 metre;
- the heel of the floating system due to the extreme wind which is compatible with the carrying out of operations, towing and mooring loads is not to exceed 5 degrees;
- the floating system is to be capable of withstanding accidental rapid increases in loading during transfer of heavy loads.

The requirements of the above items may be waived in special cases provided that adequate measures are taken which ensure the same degree of safety.

Before starting any operation during which stability may be critical, a stability test may be required in accordance with procedures previously agreed with RINA.

1.8 Mooring systems

The mooring system, used to maintain the structure or the transportation and installation vessels in the required position during the marine operations, is to be designed to withstand all the relevant design loads.

Mooring equipment must be properly sized, according to Ch. 13 of ISO 19901-6, and based on the weather limits assumed for the operations and stated in the "Marine Operations Manual".

1.9 Electrical and mechanical systems

The structure is to be equipped with all systems necessary to keep it under complete control during the marine operations, with particular care to those sensitive aspects, such as position, inclination, draft, motion, etc., that could impair the installation completion.

Depending on the nature and complexity of the operations, a separate study may be required for the purpose of selecting the most suitable system to ensure safe operation.

Systems are to be designed, constructed and installed in compliance with the applicable requirements of RINA Rules and other recognized standards.

1.10 Instrumentation

To keep the structure under effective control during construction, adequate instrumentation may be required to monitor:

- environmental conditions;
- loads and deformations;
- ballast and stability conditions;
- heel, trim and draft;
- dynamic motion;
- clearances (against seabed, surrounding objects, etc.).

All essential instruments are to be duplicated.

All instruments used are to be tested and calibrated prior to the start of operation, to the satisfaction of RINA.

1.11 Equipment for special operations

Systems and equipment used for special operations such as structure mating, installation of modules, etc. are to be thoroughly specified so as to permit the proper carrying out of operations and the evaluation of loads imposed on the structures.

The following documentation is to be submitted to RINA:

- description of the equipment;
- general arrangement and layout plans;
- strength calculations;
- material specifications;
- tests and certifications;
- construction and installation specifications.

2 Load transfer operations

2.1 General requirements

A load transfer operation includes all the activities necessary to move a structure from one supporting condition to another.

Such operations may be performed by means of lifting, pushing, pulling or ballasting variations of floating units. Where the operation involves the use of barges or other similar floating units, a mooring system is to be arranged to provide a stable support base and to achieve the necessary positioning accuracy of the barge. The buoyancy and stability of the barge are also to be analysed to check that supporting conditions are satisfactory for all the stages of the operation.

The tolerances on supports, skidways, etc. are to be such that overstresses on the structure due to ineffective restraint conditions are avoided during all stages of the operation.

Load out operations are to be planned and executed according to Clause 11 of ISO 19901-6:2009, as applicable.

3 Transportation

3.1 General

This item covers the operations necessary for transportation of the structure or parts thereof from the place of construction or assembly to the final location.

The following topics are to be considered:

- the structure transported;
- the sea-fastening arrangements;
- the floating unit or vessel structure;
- the towing arrangements;
- any other additional arrangement used.

For instrumentation systems, see [1.10].

Transport operations are to be planned and executed according to Clause 12 of ISO 19901-6 and RINA

SECTION 14 – MARINE OPERATIONS

“Rules for the Marine Operations related to the Sea Transport of Special Cargoes”, as applicable.

3.2 Towing operations

Motion responses of the towed unit are to be analysed in relation to the environmental conditions and loads specified in Sections 4 and 5.

Towing arrangements and pulling force (tug bollard pull) are to be such that the steering of the towed unit is ensured under adverse sea, wind and current conditions and in restricted waters.

Towing arrangements are to be so designed that failure of the towed unit will not occur due to possible overload.

The effects of towing force, wind, ballasting operations, etc. on the trim/heel of the structure are to be taken into consideration.

Provisions are to be made for reliable weather forecasting prior to and during the transportation.

The allowable environmental conditions to start the operations are to be determined on a case-by-case basis.

4 Offshore installation

4.1 General

The operations necessary for the offshore installation of the structure may consist of float-out, lift-off, positioning, mating and anchoring.

Installation operations are to be planned and executed according to Clauses 17 and 18 of ISO 19901-6:2009 as applicable.

For floating support structures with deep draught, such as spars, which are transported to the offshore site in horizontal position, upending operation is also to be considered.

Where the installation operations may cause the overloading of structural components, the effects of such overloading are to be monitored and controlled.

As regards the general requirements for the installation instrumentation, the provisions in [1.10] apply.

The instrumentation used for the control of the structure during the installation may include devices suitable for measurement of draft, penetration/settlement, inclination, ballast levels and parameters relating to environmental conditions.

4.2 Unloading from transport vessel

Where a structure is to be floated out from a barge or transport vessel, the unit is to be provided with suitable arrangements for the operation. The float out is generally performed by ballasting the barge, therefore the unit shall have adequate ballasting system, stability properties and all other necessary features to be operated as semisubmersible vessel.

Alternatively, the structure can be lifted off and lowered onto the water by means of heavy lift cranes or strand jack towers mounted on barge or vessel. The effectiveness and the structural strength of the

equipment used are to be checked, special attention is to be paid to the evaluation of the dynamic loads.

Another option is launching the structure from the transport barge. In this case, launch ways and rocker arm arrangements are to be designed and checked with regard to their suitability and structure strength.

The launching design is to be such that the stresses imposed on the structure will not exceed the allowable limits at any time.

The structure prepared for launching is to be provided with sufficient reserve buoyancy to compensate possible inaccuracies in the calculation of weights and buoyancy.

It is to be verified that the support structure will behave in a stable manner during and after launching and upending phases, and that sufficient bottom clearance is ensured to prevent impacts and grounding.

Environmental loads and relevant load cases to be considered in the installation engineering are to cover the requirements for structural strength, hydrostatic stability and on-bottom stability, when applicable.

4.3 Positioning, ballasting and anchoring

The support structure is to be positioned within the arranged area. Where the sea bed has been specially prepared, the tolerance in positioning is to be determined on the basis of the extent and nature of the preparation.

When required, ballasting of the support structure is to be carried out under continuous control. The influence of possible inaccuracies in the evaluation of water depth, the topography of the sea bed and obstructions thereon is to be carefully considered.

The ballast system is to permit the safe lowering of the support structure down to the required final draft. The ballasting process is to be reversible during critical stages of the above operations.

Operational aspects for ballasting and grouting are to be considered, as well as the operational aspects for mooring line installation, anchor installation and hook-up of mooring lines to floating support structures.

Final anchor holding capacity is to be field tested, according, e.g., to API RP2SK Section 7.4.3 requirements. Test loading of each mooring line is to be carried out after the mooring system is deployed.

In field validation of the minimum soil penetration depth for each type of anchors set as requirement at design stage is to be performed.

When conventional piles or suction piles are included in the foundation of the floater's station-keeping system, pile installation operations are to be planned and performed so as to match the soil mechanical properties required by relevant design. Suitable instruments are to be provided for recording of required pile penetration.

The sequence of installation operations is to ensure sufficient stability of the structure during the whole duration of the installation.

SECTION 14 – MARINE OPERATIONS

5 Construction offshore

5.1 General

The construction offshore includes the operations necessary for the completion of the floating wind turbine installation after it has been fixed to the sea bed.

5.2 Mating

Mating between the wind turbine and the support structure can be carried out either onshore or at offshore site, that is following to the sea transportation of the floating support structure.

Also, the offshore mating between wind turbine and support structure can be performed either before or following to the hook-up of the floating support structure to its station-keeping system.

When carried out offshore, the geometrical tolerances on wind turbine components to be installed (nacelle, rotor blades, structural parts of the supporting tower, etc.) are to be carefully determined prior to the commencement of each operation.

After the installation of each part, it is to be verified that the actual restraint condition complies with the design condition.

5.3 Lifting

It is to be verified that the components to be lifted have sufficient structural strength for the operation. Special attention is to be paid to the evaluation of the dynamic effects of loads.

For all lifting operations, the effectiveness and the structural strength of the equipment used are to be considered.

Such equipment may consist in:

- Vessel or barge mounted cranes;
- Rigging system (slings, shackles, spreader frames, etc.).

The mooring arrangement or DP capabilities of the vessels involved in the lifting (heavy lift vessel, cargo barge, etc.) are to be checked against the design environmental actions.

When the crane is operating from a jack-up vessels, site-specific assessment and soil bearing verification shall be performed, to ensure the crane vessel stability under the specific spud support conditions.

Bumpers and stabbing guides installed to ensure a smooth gradual placing of lifted parts are to have adequate strength and be so built that accidental overloads do not lead to damage to primary structures.

6 Power cable laying

6.1 General requirements

The linking of the wind farm turbines to the offshore substation(s), carried out by array cables, and the linking between offshore substations and the onshore grid, carried out by export cables, require the

installation and protection of relevant power cables, which are typically composite cables incorporating both power conductors and optical fiber packages.

The installation, and relevant protection, of such cables, require a high degree of expertise for the planning and execution of offshore operations, by including the preparation of a Cable Transport and Installation Method Statement, drawings, analyses and calculations, related to:

- cable load-out;
- cable transport;
- pull-in operations;
- seabed preparation and trenching;
- cable lay;
- landfall installation;
- cable lay monitoring and post lay survey;
- cable cutting method;
- cable protection system installation.

Proper engineering analyses are to be developed in order to demonstrate that the cable structural limits defined by its manufacturer (maximum allowable tension, minimum allowable bending radius, etc.) are not exceeded during the installation.

Similar engineering analyses are necessary to verify the adequacy of the mooring arrangement or DP capabilities of the vessels, as well as any other possible critical aspect that could affect the operation result.

For specific provisions relevant to the execution of laying, burial and pull-in of subsea power transfer cables, appropriate reference can be made to the provisions of ISO 29400, Clause 20.

6.2 Cable laying equipment

The cable laying equipment commonly consists in several parts mounted on the laying vessel, such as:

- Carousels;
- Reel supports and drive systems;
- Conveyors;
- Tensioners;

Over boarding chutes.

The structural design and the mechanical capabilities of these pieces of equipment are to be checked through dedicated engineering analyses, to demonstrate their adequacy for the specific situation (cable features, water depth, etc.).

In addition, the main mechanical components should be subjected to overload testing before the operations.